

TRIBHUVAN UNIVERSITY
INSTITUTE OF ENGINEERING
Examination Control Division
2079 Bhadra

Exam.	Regular		
Level	BE	Full Marks	80
Programme	BEX, BEI, BCT	Pass Marks	32
Year / Part	III / I	Time	3 hrs.

Subject: - Computer Organization and Architecture (CT 603)

- ✓ Candidates are required to give their answers in their own words as far as practicable.
 - ✓ Attempt **All** questions.
 - ✓ The figures in the margin indicate **Full Marks**.
 - ✓ Assume suitable data if necessary.
1. Explain about the structural and functional viewpoint of a computer. Explain different elements of bus design. [4+2]
 2. Write a code for $X = ((A+B)/C) + (D - E)$ using three addresses, two addresses, one address and zero address instruction format. [8]
 3. List out the different types of addressing modes and explain each of them with suitable example. [8]
 4. Describe the operation of hardwired control unit with a typical block diagram. Explain the operation of microprogram sequencer used in microprogrammed control unit. [5+5]
 5. Explain arithmetic pipelining with example. Describe different types of pipeline hazards with example. [4+6]
 6. Draw the flowchart for Non-Restoring Division. Perform 13/5 using restoring division. [4+6]
 7. Explain floating point addition and subtraction algorithm with an example. [6]
 8. Describe how Set-Associative Mapping works in Cache memory mapping. Explain different write policy techniques in cache memory. [3+5]
 9. Elaborate the roles of I/O interface in a computer system. Explain how data transfer is performed with programmed I/O technique with necessary diagram. [10]
 10. Compare and contrast the interconnection structures used in multiprocessing environment. [4]

TRIBHUVAN UNIVERSITY
INSTITUTE OF ENGINEERING
Examination Control Division
2079 Baishakh

Exam.	Back		
Level	BE	Full Marks	80
Programme	BEX, BEI, BCT	Pass Marks	32
Year / Part	III / I	Time	3 hrs.

Subject: - Computer Organization and Architecture (CT 603)

- ✓ Candidates are required to give their answers in their own words as far as practicable.
- ✓ Attempt All questions.
- ✓ The figures in the margin indicate Full Marks.
- ✓ Assume suitable data if necessary.

1. What is performance balance and why it is required? Explain different elements of bus design. [2+4]
2. Describe the instruction cycle state diagram. Write down the code to evaluate $Y = (A-B+C)*(E+F/G)$ in three addresses, two address, one address and zero address instruction formats. [4+6]
3. List out the different types of addressing modes and explain them with suitable example for each. [8]
4. Differentiate between control memory and main memory. Draw the block diagram of Microprogram Sequencer for a control memory, explain its operations. [3+7]
5. What is vector processing? How pipelining improves the performance of a computer? Explain with an example. [10]
6. Explain restoring division algorithm. Use this algorithm to divide 31 (Dividend) by 13 (divisor). [8]
7. Explain floating point multiplication algorithm with an example. [6]
8. What do you mean by write policy? Discuss and differentiate direct mapping and associative mapping functions in cache design. [8]
9. What are the functions of I/O Module? Why priority interrupt is needed for data transmission between COU and I/O device. Explain the types of priority interrupt in detail. [10]
10. Compare and contrast the interconnection structures used in multiprocessing environment. [4]

TRIBHUVAN UNIVERSITY
INSTITUTE OF ENGINEERING
Examination Control Division
2078 Bhadra

Exam.	Regular		
Level	BE	Full Marks	80
Programme	BEX, BEL, BCT	Pass Marks	32
Year / Part	III / I	Time	3 hrs.

Subject: - Computer Organization and Architecture (CT 603)

- ✓ Candidates are required to give their answers in their own words as far as practicable.
- ✓ Attempt **All** questions.
- ✓ The figures in the margin indicate **Full Marks**.
- ✓ Assume suitable data if necessary.

1. Explain different types of bus arbitration and compare them. [6]
2. Explain different types of data manipulation instructions with example. [8]
3. Explain the component of CPU. Comparison between RISC and CISC architecture. [2+6]
4. Explain the organization structure of a microprogram control unit and the generation of control signals using microprogram. [10]
5. What is meant by hazard in pipelining? Explain with example data and control hazards in pipeline conflict. [4+6]
6. Explain the non-restoring division algorithm for division. Divide 10/5 using non-restoring division. [5+5]
7. Explain the floating point addition and subtraction process using flow chart. [3+3]
8. Explain Least Recently Used (LRU) replacement algorithm in case of hit and miss with suitable example. [8]
9. Differentiate between isolated and memory mapped Input-output. Explain with block diagram of DMA transfer in a computer system. [4+6]
10. Compare and contrast the interconnection structures used in multiprocessor system. [4]

TRIBHUVAN UNIVERSITY
 INSTITUTE OF ENGINEERING
Examination Control Division
 2078 Kartik

Exam.	Back		
Level	BE	Full Marks	80
Programme	BEX, BCT	Pass Marks	32
Year / Part	III / I	Time	3 hrs.

Subject: - Computer Organization and Architecture (CT 603)

- ✓ Candidates are required to give their answers in their own words as far as practicable.
- ✓ Attempt **All** questions.
- ✓ The figures in the margin indicate **Full Marks**.
- ✓ Assume suitable data if necessary.

1. Differentiate between computer organization and architecture. Compare and explain the bus structure of typical computer system. [2+4]
2. Write down the code for $Y = (A-B/C) \times (D+E \times G) / F$ using three address, two address, one address and zero address instruction format. [8]
3. Comparison between different types of addressing modes with its advantages and disadvantages. [10]
4. Write down the symbolic microprogram for fetch routine and addition execute routine. Explain with diagram the working of microprogram sequencer for control memory. [4+6]
5. How pipeline processing is done in an instruction pipeline? Explain four segment instruction pipeline with timing diagram. [3+5]
6. Describe the procedure for floating point addition and subtraction with help of flowchart and example. [6]
7. Draw the flowchart of Booth's multiplication algorithm and multiply -7×-10 using Booth's multiplication algorithm. [4+4]
8. Explain various mapping methods used in cache memory organization and compare each of them with example. [10]
9. Explain with block diagram of DMA controller. How DMA techniques is different from programmed Input-Output? [6+4]
10. Differentiate between tightly coupled multiprocessor and loosely coupled multiprocessor. [4]

TRIBHUVAN UNIVERSITY
 INSTITUTE OF ENGINEERING
Examination Control Division
 2076 Chaitra

Exam.	Regular		
Level	BE	Full Marks	80
Programme	BEX, BCT	Pass Marks	32
Year / Part	III / I	Time	3 hrs.

Subject: - Computer Organization and Architecture (CT 603)

- ✓ Candidates are required to give their answers in their own words as far as practicable.
- ✓ Attempt *All* questions.
- ✓ The figures in the margin indicate **Full Marks**.
- ✓ Assume suitable data if necessary.

1. Draw the instruction cycle state diagram with example. [6]
2. Write down the code to evaluate $Y = (A - B/C) * [D + (E * G)]$ in three address, two address, one address and zero address instruction formats. [8]
3. Define addressing modes. Mention the different types of addressing modes and comparison between them. [2+6]
4. How address of micro instruction is generated by next address generator in control unit? Explain with suitable diagram. [8]
5. Explain four stage instruction pipeline and also draw a time-space diagram for four segments having six tasks. [10]
6. Explain the Booth's algorithm for multiplication. Multiply $10 \times (-5)$ using Booth's multiplication algorithm. [5+5]
7. Comparison between restoring and non-restoring division algorithms with example. [6]
8. Define cache mapping techniques. Explain direct mapping technique with suitable diagram. Why replacement algorithm is necessary in associative mapping? Justify. [2+4+4]
9. Comparison between program I10, Interrupt driven I10 and direct memory access. Why data communication processor is required in an I10 organization. [8+2]
10. Discuss about hypercube interconnection network with example. [4]

TRIBHUVAN UNIVERSITY
INSTITUTE OF ENGINEERING
Examination Control Division
2076 Ashwin

Exam.	Back		
Level	BE	Full Marks	80
Programme	BEX, BCT	Pass Marks	32
Year / Part	III / I	Time	3 hrs.

Subject: - Computer Organization and Architecture (CT 603)

- ✓ Candidates are required to give their answers in their own words as far as practicable.
- ✓ Attempt All questions.
- ✓ The figures in the margin indicate Full Marks.
- ✓ Assume suitable data if necessary.

1. What is PCI? Explain the design goals and performance metrics for a computer system regarding its organization and architecture. [1+5]
2. Write the arithmetic statement $Y=(W+X)*(Y-Z)$ using Zero, One, Two and Three address instruction format. [8]
3. Explain the different types of addressing modes and compare each of them. [8]
4. Explain block diagram of micro-programmed control organization. Describe various fields in micro-instruction format with diagram showing different fields. [4+6]
5. Describe the hazard in a pipeline. Explain the different types of hazards. How can these be overcome? [2+4+2]
6. Write an algorithm of booth multiplication. Perform 8×4 using booth multiplication algorithm. [10]
7. Differentiate between restoring division and non-restoring division and non-restoring division algorithm. [6]
8. Describe cache operation in briefly. Explain about associative mapping technique. Give reasons why replacement algorithm is not required in direct mapping technique. [2+6+2]
9. Explain the DMA operation with block diagram. How does DMA have request over the CPU when both request a memory transfer? [8+2]
10. Discuss about tightly-coupled multiprocessor with block diagram. [4]

Exam.	Back		
Level	BE	Full Marks	80
Programme	BEX, BCT	Pass Marks	32
Year / Part	III / I	Time	3 hrs.

Subject: - Computer Organization and Architecture (CT603)

- ✓ Candidates are required to give their answers in their own words as far as practicable.
- ✓ Attempt All questions.
- ✓ The figures in the margin indicate Full Marks.
- ✓ Assume suitable data if necessary.

1. Explain the Interconnection structures of computer. [6]
2. Write codes for given operation using zero, one, two and three address instruction format. [8]
3. Differentiate between RISC and CISC architecture. [6]
4. Draw the diagram of Micro-programmed sequencer for a control memory and explain it. [10]
5. Explain six stage instruction pipeline with example. [10]
6. Explain Booth's multiplication algorithm for signed 2's complement numbers in details with a suitable example and give the hardware requirements diagram. [10]
7. Differentiate between restoring and non-restoring division. [6]
8. Explain the various types of elements of cache design and also explain the various mapping techniques used in cache with example. [4+6]
9. Why ILO processor is needed in ILO organization? Explain the CPU-IOP communication with diagram. [3+7]
10. Write down the characteristics of multiprocessors. [4]

TRIBHUVAN UNIVERSITY
 INSTITUTE OF ENGINEERING
Examination Control Division
 2075 Chaitra

Exam.	Regular / Back		
Level	BE	Full Marks	80
Programme	BEX, BCT	Pass Marks	32
Year / Part	III / I	Time	3 hrs.

Subject: - Computer Organization and Architecture (CT 603)

- ✓ Candidates are required to give their answers in their own words as far as practicable.
- ✓ Attempt All questions.
- ✓ The figures in the margin indicate Full Marks.
- ✓ Assume suitable data if necessary.

1. Define computer architecture. Discuss the limitations of using single bus system to connect different devices. What does width of address bus represent in a system? [2+2+2]
2. Design an 2-bit ALU that can perform subtraction, AND, OR and XOR. [8]
3. Write a code for $Y=(A+B)/C + D/(E*F)$ using three address, two address, one address and zero address instruction format. [8]
4. Differentiate hardwired and micro-programmed control unit. Draw and explain block diagram of micro-programmed sequencer for control memory. [10]
5. Derive expression showing speed up ratio equals number of segments in pipeline. Discuss in detail about data dependency problem that arises in pipelining along with its solution. [3+5]
6. Write an algorithm for non restoring division. Perform the $10/3$ using restoring division algorithm. [3+7]
7. Multiply -6×-11 using Booths Multiplication algorithm. [6]
8. Write characteristics of memory system? Suppose main memory has 64 blocks and cache memory has 8 blocks when 10 blocks of main memory are used, show how mapping is performed in direct mapping technique. [4+6]
9. Explain three reasons behind the requirement of I/O interfaces. Why memory address spaces are reduced memory mapped I/O ? Describe DMA controller with suitable block diagram. [3+2+5]
10. Explain inter-processor synchronization with example. [4]

Exam.	Back		
Level	BE	Full Marks	80
Programme	BEX, BCT	Pass Marks	32
Year / Part	III / I	Time	3 hrs.

Subject: - Computer Organization and Architecture (CT603)

- ✓ Candidates are required to give their answers in their own words as far as practicable.
- ✓ Attempt All questions.
- ✓ The figures in the margin indicate Full Marks.
- ✓ Assume suitable data if necessary.

1. Explain instruction cycle state diagram with interrupt. [6]
2. Write codes using 3, 2, 1 and 0 address instruction formats to perform given operation. [8]
 $X = (A * B / C) - (D + E / F)$
3. Describe various fields in microinstruction format. Explain about the sequencing techniques used in microinstruction format with necessary diagram. [10]
4. Explain microinstruction format showing all the fields in detail. Write symbolic microprogram for fetch cycle. [10]
5. Explain arithmetic pipeline with an example of 4 segments. Describe different types of array processing. [6+4]
6. Write an algorithm flow chart and hard ware design of restoring division with example. [10]
7. Draw a flow chart for floating point multiplication algorithm. [4]
8. Explain about associative mapping technique. Give reasons why replacement algorithm is required in associative mapping technique? [8]
9. Explain the block diagram of DMA controller and also explain how DMA is used to transfer data from peripheral. [10]
10. Differentiate between tightly coupled multiprocessors and loosely coupled multiprocessors. [4]

Level	BE	Full Marks	80
Programme	BEX, BCT	Pass Marks	32
Year / Part	III / I	Time	3 hrs.

Subject: - Computer Organization and Architecture (CT603)

- ✓ Candidates are required to give their answers in their own words as far as practicable.
- ✓ Attempt All questions.
- ✓ The figures in the margin indicate Full Marks.
- ✓ Assume suitable data if necessary.

1. Draw instruction cycle, state diagram with interrupt and explain it. [6]
2. Write down the need for addressing modes. Explain the various addressing modes with example. [8]
3. Write the arithmetic statement
 $X = (P+Q) \times (R+S)$ using zero, one, two and three address instruction format [8]
4. Compare and contrast between hardwired and microprogrammed control unit. Explain the micro program sequencer used in microprogrammed control unit. [4+6]
5. What is pipeline? How performance of computer is increased using pipelining? Explain with example. [2+6]
6. Perform multiplication - 7×3 using booth algorithm. [6]
7. Explain the process of floating point number addition and subtraction with flowchart and example. [10]
8. Write down the characteristics of memory system. Suppose main memory has 32 blocks and cache memory has 8 blocks when 12 blocks of main memory are used, show how mapping is performed in direct mapping. [4+6]
9. Explain I/O Interface. Compare programmed I/O, Interrupt driven I/O and direct memory access (DMA). [2+8]
10. Explain various configurations of OS in multiprocessor system. [4]

Exam.	New Back (2066 & Later Batch)		
Level	BE	Full Marks	80
Programme	BEX, BCT	Pass Marks	32
Year / Part	III / I	Time	3 hrs.

Subject: - Computer Organization and Architecture (CT603)

- ✓ Candidates are required to give their answers in their own words as far as practicable.
- ✓ Attempt All questions.
- ✓ The figures in the margin indicate Full Marks.
- ✓ Assume suitable data if necessary.

1. What do you mean by interconnection structure? Explain different types of interconnections indeed required in Computer Architecture. [2+4]
2. Write a code for $Y = A * (B + D / C) + (G * E) / F$ using three addresses, two address, one address and zero address instruction format. [8]
3. Following instructions are given: [10]
 - i) LDA 2000H
 - ii) MVI B, 32H
 - iii) STAX D
 - iv) MOV A, B

Which addressing modes are used in the above instructions? Explain briefly about them.
4. Explain microinstruction format used in microprogramming Control unit and write micro program for fetch cycle. [6+4]
5. Explain in detail how the arithmetic pipeline increases the performance of a system. [7]
6. "RISC has the ability to use efficient instruction pipeline". Justify the statement. [3]
7. Explain signed binary division algorithm. Use the non-restoring division algorithm to divide 15 by 4. [8]
8. Explain floating point addition and subtraction algorithm with example. [6]
9. Describe how set associative mapping combines the feature of direct and associated mapping technique. Explain different write policy techniques in cache memory. [5+3]
10. Why input-output processor is needed in an input-output organization? How does a computer know which device issued the interrupt; if multiple devices, how does the selection take place? [5+5]
11. Describe how the multiprocessor systems increase the performance level and reliability. [4]

Exam.	Regular		
Level	BE	Full Marks	80
Programme	BEX, BCT	Pass Marks	32
Year / Part	III / I	Time	3 hrs.

Subject: - Computer Organization and Architecture (CT603)

- ✓ Candidates are required to give their answers in their own words as far as practicable.
- ✓ Attempt All questions.
- ✓ The figures in the margin indicate Full Marks.
- ✓ Assume suitable data if necessary.

1. Explain instruction cycle state diagram with interrupt. [6]
2. Write a code for $Y = A/(B+C) + (D+E)*F$ using three address, two address, one address and zero address instruction format. [8]
3. Explain different types of data manipulation instructions with examples. [10]
4. Why is micro-programmed control unit more flexible as compared to hardwired control unit? Explain the sequencing technique used in control memory. [10]
5. Explain the function of four segment pipeline and also draw a space diagram for four segment pipeline with example. [10]
6. Write an algorithm for division of floating point number. [4]
7. Explain Booth algorithm of multiplication with hardware implementation diagram and multiply- 10×6 . [10]
8. Explain major characteristics of memory. Explain LRUC (Least Recently Used) replacement policy with example. [8]
9. Why I/O processor is necessary in an input-output organization? Explain about DMA control with necessary diagram. [10]
10. Design for 4×4 omega switching network and show the switch setting required to connect input 3 to output 1. [4]

Exam.	Regular		
Level	BE	Full Marks	80
Programme	BEX, BCT	Pass Marks	32
Year / Part	III / I	Time	3 hrs.

Subject: - Computer Organization and Architecture (CT603)

- ✓ Candidates are required to give their answers in their own words as far as practicable.
- ✓ Attempt **All** questions.
- ✓ The figures in the margin indicate **Full Marks**.
- ✓ Assume suitable data if necessary.

1. Define computer architecture and computer organization. How can we maintain a performance balance between processor and memory? Discuss the limitations of using single bus system to connect different devices in any given system. [2+2+2]
2. What do you mean by instruction format? Write codes for given operation using 3-,2-,1- and 0- address instruction format. [4+8]

$$X=(A-B*F)*C+D/E$$
3. Differentiate between RISC and CISC. [6]
4. What factors cause micro-programmed control unit to be selected over hardwired control unit. Explain with relevant block diagram, how address of control memory is selected in micro-programmed control unit. [3+7]
5. Describe Flynn's classification. Explain control pipeline hazard and its solutions. [4+6]
6. Explain Booth's multiplication hardware algorithm with diagram. Multiply -5×-9 using Booth's multiplication algorithm. [5+5]
7. Draw the flowchart for division of floating point numbers. [4]
8. Draw the memory hierarchy. Explain direct cache mapping with its merits and demerits. [2+6]
9. Differentiate between Isolated I/O and Memory-mapped I/O. Describe DMA controller with suitable block diagram. [4+6]
10. Discuss about inter process synchronization with the suitable mechanism? [4]

Exam.	New Back (2066 & Later Batch)		
Level	BE	Full Marks	80
Programme	BEX, BCT	Pass Marks	32
Year / Part	III / I	Time	3 hrs.

Subject: - Computer Organization and Architecture (CT603)

- ✓ Candidates are required to give their answers in their own words as far as practicable.
- ✓ Attempt All questions.
- ✓ The figures in the margin indicate Full Marks.
- ✓ Assume suitable data if necessary.

1. Differentiate between computer architecture and computer organization. Explain the computer functions with different cycles. [3+3]
2. Write a code for $Y = (A+B)*(C+D)+G/E*F$ using three address, two address one address and zero address instruction format. [8]
3. Mention the different types of addressing mode and compare each other. [10]
4. Explain the address sequencer with the help of a block diagram. Explain about microinstruction format in detail. [5+5]
5. Define pipeline and explain its types. Describe different pipeline hazards with example. [4+6]
6. Draw the flowchart for restoring division method. [4]
7. Explain Booth multiplication algorithm. Multiply -6×12 using Booths algorithm. [4+6]
8. Draw the memory hierarchy. Explain Associative Cache Mapping with example. [2+6]
9. What are the different types of priority interrupt? Explain the communication between CPU and IOP with necessary block diagram. [4+6]
10. Explain about multiprocessor and multiprocessing in brief. [4]

Exam.	Regular		
Level	BE	Full Marks	80
Programme	BEX, BCT	Pass Marks	32
Year / Part	III / 1	Time	3 hrs.

Subject: - Computer Organization Architecture (CT603)

- ✓ Candidates are required to give their answers in their own words as far as practicable.
- ✓ Attempt All questions.
- ✓ The figures in the margin indicate Full Marks.
- ✓ Assume suitable data if necessary.

1. What are the major differences between computer architecture and computer organization? What does the width of data bus and address bus represent in a system? Why is bus hierarchy required? [2+2+2]
2. Explain the general organization of register in CPU. Describe the operation of LD (load) instruction under various addressing modes with syntax. [6+4]
3. What are the different types of instructions? How can you perform $X = (A+B) \times (C+D)$ operation by using zero, one, two and three address instruction format. Assume A, B, C, D, X are memory address. [3+5]
4. What is address sequencing? Explain the selection of address for control memory with its block diagram. [3+7]
5. Explain the Arithmetic pipeline and instruction pipeline with example. [10]
6. Draw the flowchart for floating point Division. [4]
7. Design a booth multiplication algorithm hardware. Multiply 5 and -6 using booth multiplication algorithm. [4+4]
8. Explain cache organization. Explain the cache mapping techniques with example. [4+6]
9. Highlight the role of I/O interface in a computer system. Describe the drawbacks of programmed I/O and interrupt driven I/O and explain how DMA overcomes their drawbacks. [4+6]
10. How can multiprocessor be classified according to their memory organization? Explain. [4]

B.C.T
III / I

37 TRIBHUVAN UNIVERSITY
INSTITUTE OF ENGINEERING
Examination Control Division
2071 Shawan

Exam.	New Back (2066 & Later Batch)		
Level	BE	Full Marks	80
Programme	BEX, BCT	Pass Marks	32
Year / Part	III / I	Time	3 hrs.

Subject: - Computer Organization and Architecture (CT603)

- ✓ Candidates are required to give their answers in their own words as far as practicable.
- ✓ Attempt All questions.
- ✓ The figures in the margin indicate Full Marks.
- ✓ Assume suitable data if necessary.

1. What do you understand by Bus Interconnection? What are the driving factors behind the need to design for performance? [2+4]
2. Explain Instruction Format with its types? Illustrate the code to evaluate to evaluate: $Y = (A+B) * (C+D)$ using three address, two address, one address and zero address instruction formats. [2+6]
3. Describe the instruction cycle state diagram? Design a 2-Bit ALU that can perform addition, AND, OR operations. [3+3]
4. Explain the organization of a control memory. Discuss the microinstruction format with the help of a suitable example. [4+6]
5. Discuss about parallel processing? How parallel processing can be achieved in pipelining, explain it with time-space diagram for four segments pipeline having six tasks. [4+6]
6. Write down the detail algorithm of Booth Multiplication. Illustrate the multiplication of (9) and (-3) using 2's complement method. [5+5]
7. What is Memory Hierarchy and why it is formed in computer system? Explain the Direct cache memory mapping technique using organization diagram and appropriate example. [2+6]
8. What are the functions of I/O Module? What is the purpose of priority interrupt; explain priority interrupt types with key characteristics. [3+7]
9. Differentiate the following [4x3]
 - a. RISC and CISC
 - b. Restoring and Non-Restoring Division
 - c. Crossbar Switch and Multistage Switching Network

36 TRIBHUVAN UNIVERSITY
INSTITUTE OF ENGINEERING
Examination Control Division
2070 Chaitra

Exam.	Regular		
Level	BE	Full Marks	80
Programme	BEX, BCT	Pass Marks	32
Year / Part	III / I	Time	3 hrs.

Subject: - Computer Organization and Architecture (CT603)

- ✓ Candidates are required to give their answers in their own words as far as practicable.
- ✓ Attempt All questions.
- ✓ The figures in the margin indicate Full Marks.
- ✓ Assume suitable data if necessary.

1. Explain the interconnection of CPU with Memory and I/O devices along with different operations over them. [3+3]
2. Write down the $Y = A/B + (C \times D) + F(H/G)$ equation in three address, two address, one address and zero address instruction. [8]
3. Mention the different types of addressing modes. Compare each of them with algorithm as well as advantages and disadvantages. [10]
4. Differentiate between hardwired and micro-programmed control unit. How does a sequencing logic work in micro-programmed control unit to execute a micro-program? [4+6]
5. Explain the arithmetic pipeline and instruction pipeline with example. [10]
6. Explain the non-restoring division along with its algorithm, flowchart and example. [8]
7. Explain the Booth algorithm and multiply $Y = 8 \times 9$ using Booth algorithms. [6]
8. Mention the characteristics of computer memory. Differentiate between associative mappings and set associative mapping with example. [3+5]
9. How does DMA overcome the problems of programmed I/O and interrupt-driven I/O techniques? Explain. [5]
10. Why IOP is use in I/O organization? Explain. [5]
11. Explain the characteristics of multiprocessors. [4]

37 TRIBHUVAN UNIVERSITY
 INSTITUTE OF ENGINEERING
Examination Control Division
 2070 Ashad

Exam.	New Batch (2066 & Later Batch)		
Level	BE	Full Marks	80
Programme	BEX, BCT	Pass Marks	32
Year / Part	III / I	Time	3 hrs.

Subject: - Computer Organization and Architecture (CT603)

- ✓ Candidates are required to give their answers in their own words as far as practicable.
- ✓ Attempt All questions.
- ✓ The figures in the margin indicate Full Marks.
- ✓ Assume suitable data if necessary.

1. What is performance balance and why is it required? Explain different elements of bus design. [6]
2. Define the addressing mode and explain the different types of addressing modes with example. [10]
3. What are the stages of ALU design? Explain with the example of 2-bit ALU performing addition, subtraction, OR and XOR. [8]
4. What are the differences between hardwired implementation and micro-programmed implementation of control unit? Explain with steps involved when you are designing micro-program control unit. [4+6]
5. What is instruction hazard in pipeline? What is the four segment instruction pipeline? Explain with example. [2+8]
6. How division operation can be performed? Explain with its hardware implementation. [10]
7. Draw a flowchart of floating point subtraction. [4]
8. What are the major differences between different cache mapping techniques? Suppose main memory has 32 blocks and Cache memory has 8 blocks when 10 blocks of main memory are used, show how mapping is performed in direct mapping technique. [6+2]
9. Differentiate between programmed I/O, interrupt-driven I/O and direct memory access (DMA). [10]
10. Explain the interprocessor synchronization with example. [4]

Exam.	Regular		
Level	BE	Full Marks	80
Programme	BEX, BCT	Pass Marks	32
Year / Part	III / I	Time	3 hrs.

Subject - Computer Organization and Architecture (CT603)

- ✓ Candidates are required to give their answers in their own words as far as practicable.
- ✓ Attempt All questions.
- ✓ The figures in the margin indicate Full Marks.
- ✓ Assume suitable data if necessary.

1. Differentiate between computer organization and architecture. What do you mean by bus interconnection? [3+3]
2. What are the different types of instruction formats? Explain with example. [10]
3. Define data manipulation instruction. Explain the logical and bit manipulation instruction with mnemonic code. [3+5]
4. What is address sequencing in control unit? Explain with necessary figure. [10]
5. What is vector processing? How pipelining improves the performance of a computer? Explain with example. [10]
6. Explain the restoring division algorithm and hardware design with example. [10]
7. Draw the flowchart of floating point multiplication. [4]
8. What is cache memory? What are the different ways the cache can be mapped? Explain with example. [2+6]
9. What are the functions of I/O Module? Why priority interrupt is needed for data transmission between CPU and I/O device. Explain the types of priority interrupt in detail. [10]
10. Compare and contrast the interconnection structures used in multiprocessing environment. [4]

Exam.	New Back (2066 & Later Batch)		
Level	BE	Full Marks	80
Programme	BEX, BCT	Pass Marks	32
Year / Part	III / I	Time	3 hrs.

Subject: - Computer Organization and Architecture (CT 603)

- ✓ Candidates are required to give their answers in their own words as far as practicable.
- ✓ Attempt All questions.
- ✓ The figures in the margin indicate Full Marks.
- ✓ Assume suitable data if necessary.

1. Explain bus hierarchy and why it is required. Describe method of bus arbitration. [6]
2. Write down the code to evaluate $Y=AB+(C/D)+E(F/G)$ in three address, two address, one address and zero address instruction format. [8]
3. Compare RISC and CISC architecture. [5]
4. What do you mean by data manipulation instruction? Explain the logical and bit manipulation instruction with mnemonics code. [5]
5. Design microinstruction format, symbolic and binary micro program that can perform fetch cycle, indirect cycle and add operation. Also design and describe sequencing technique that is used in control unit. [10]
6. What is arithmetic pipelining? Explain with example. [6]
7. How can we increase the performance of a computer by adopting vector computation? [4]
8. Describe floating point addition and subtraction flow chart. [6]
9. How division of signed integers can be performed? Explain with example. [8]
10. What do you mean by mapping function? Why replacement algorithm is used in associative and set associative mapping? Explain with example. [2+6]
11. Describe interrupt driven I/O. Compare interrupt driven I/O with programmed I/O. Explain how data transfer is performed with direct memory access (DMA). [3+3+4]
12. Discuss the difference between tightly coupled multiprocessor and loosely coupled multiprocessors? [4]

TRIBHUVAN UNIVERSITY
INSTITUTE OF ENGINEERING
Examination Control Division
2079 Bhadra

Exam.	Regular		
Level	BE	Full Marks	80
Programme	BEL, BEX, BCT, BAG, BCH	Pass Marks	32
Year / Part	III / I	Time	3 hrs.

Subject: - Probability and Statistics (SH 602)

- ✓ Candidates are required to give their answers in their own words as far as practicable.
- ✓ Attempt *All* questions.
- ✓ The figures in the margin indicate **Full Marks**.
- ✓ Necessary tables are attached herewith.
- ✓ Assume suitable data if necessary.

1. Define five number summaries of data. Prepare the box-plot for the following data of daily registration of workers in the construction site. 34, 42, 66, 40, 59, 36, 41, 35, 36, 62, 43, 30, 43, 32, 44, 58, 53, 50, 48 and 38. [6]
2. State Bayes' Theorem. In a bolt factory, machines A, B and C manufacture respectively 25%, 35% and 40% of the total population. Among their total output, 5%, 4% and 2% are found to be defective bolts. If a bolt drawn from the total product is found to be defective,
 - a) What is the probability that it was manufactured by A?
 - b) What is the probability that it was manufactured by B?
 - c) What is the probability that it was manufactured by C?
 - d) Which machine seems most likely to produce the defective bolts? [6]
3. Discuss the poisson distribution as limit case of binomial distribution. In a certain factory turning out razor blades there is a small chance 1/500 for any blade to be defective. The blades are supplied in packets of 50. Use suitable probability distribution to calculate the approximate number of packets containing in of 10,000 packets. [5]
 - a) no defective b) One defective and c) Two defective
4. What are the parameters used in Poisson distribution? A manufacturer of pins knows that on the average 3 on 100 of its production is defective. He sells pins in boxes of 100 and guarantees that not more than 2 pins will be defective. What is the probability that a box selected at random (i) will meet the guaranteed quality? (ii) will not meet the guaranteed quality? [5]
5. Define the normal distribution and standard normal distribution. Under what condition binomial distribution follows normal distribution. [5]
6. Describe the conditions for the probability density function. The length of time (in minutes) that a certain lady speaks on the telephone is found to be random phenomenon, with a probability function specified by the probability density function $f(x)$ as

$$f(x) = \begin{cases} Ae^{-x/5} & \text{for } x \geq 0 \\ 0 & \text{elsewhere} \end{cases}$$

Find value of A. What is the probability that the number of minutes that she will take over the phone is

 - a) more than 10 minutes
 - b) less than 5 minutes and
 - c) between 5 and 10 minutes. [5]
7. A population of the four numbers 5, 6, 9, 12.
 - a) Write down all possible sample size of two without replacement.
 - b) Verify population mean is equal to the mean of sample mean.
 - c) Calculate the standard error of the sample distribution of sample mean. [5]
8. State Central Limit Theorem and write any two applications of it. The lifetime of a certain brand of an electric bulb may be considered a random variable with mean 1200 hours and standard deviation 250 hours. find the probability that average lifetime of 60 bulbs
 - a) exceed 1400 hours
 - b) is between 1100 hours and 1300 hours
 - c) is less than 1100 hours [5]

9. The following are the average weekly losses of worker-hours due to accidents in 10 industrial plants before and after a certain safety program was put into operation:

Before	45	73	46	124	33	57	83	34	26	17
After	36	60	44	119	35	51	77	29	24	11

Use $\alpha = 0.05$ to test whether the safety program is effective.

[5]

10. From a random sample of 60 buses, Montreal's mass-transit office has calculated the mean number of passengers per km to be 4.1. From previous studies, the population standard deviation is known to be 1.2 passengers per km.

[5]

- a) Find the standard error of the mean. (Assume that the bus fleet is very large.)
 b) Construct a 95 percent confidence interval for the mean number of passengers per Km for the population.

11. The information obtained during rapid assessment after earthquake about damage grade with respect to structure of building. Test whether there exist any association between damage grade with structure of building at 10% level of significant. [χ^2 value of 6 d.f = 12.592]

Damage Grade	Structure of Building		
	Frame	Masonry	Mixed
D1	303	345	11
D2	37	389	22
D3	14	875	310
D4	5	1083	13

Write down the steps involved in the hypothesis testing of difference of mean when both the sample are small.

[5]

12. Rick Douglas, the new manager of food Barn, is interested in the percentage of customers who are totally satisfied with the store. The previous manager had 86 percent of the customers totally satisfied and Rick claims the same is true today. Rick sampled 187 customers and found 157 were totally satisfied. At the 5 percent significance level, is there evidence that Rick's claim is valid?

[5]

13. The study was done to study the ambient temperature on the electric power consumed by a chemical plant. Following table represent the data which are collected from an experimental pilot plant.

Temperature (F)	27	45	72	58	31	60	34	74
Electric power (BTU)	250	285	320	295	265	298	267	321

Fit a simple regression line, assuming that the relationship between them is linear. Also, predict the power consumption for an ambient temperature of 65°F.

[5]

14. Define Karl Pearson Correlation coefficient and its coefficient of determination and write down the basic properties of it.

[5]

15. Following data reveals the 27 sample of paired data (X, Y) measured in the suitable units. Use scientific calculator to compute the required sums. Also compute following measures by using the suitable statistical formulae.

[8]

X	75	96	80	72	93	71	86	72	79
	98	77	84	70	96	85	84	94	71
	89	92	76	88	78	83	96	87	71
Y	166	197	176	164	177	189	173	175	185
	182	181	185	190	187	159	193	167	164
	194	177	166	162	192	156	158	182	175

- a) Sample Average of both variables X and Y.
 b) Sample standard deviation of both the variables X and Y
 c) Which series is more uniformity as regard to the variability of the data?

Exam.	Back		
	Level	BE	Full Marks
Programme	BEL, BEX, BCT, BAG	Pass Marks	32
Year / Part	III / I	Time	3 hrs.

Subject: - Probability and Statistics (SH 602)

- ✓ Candidates are required to give their answers in their own words as far as practicable.
- ✓ Attempt All questions.
- ✓ The figures in the margin indicate Full Marks.
- ✓ Necessary tables are attached herewith.
- ✓ Assume suitable data if necessary.

1. What is dispersion? Explain what do you understand by absolute and relative measures of dispersion. The marks distribution of 100 students of a college is as follows: [6]

Marks	10-20	20-40	40-70	70-90	90-100
No of students	15	20	30	20	15

Find the mean, median and standard deviation on of given distribution.

2. By examining the chest x-ray, the probability that T.B is detected when a person is actually suffering from it is 0.99. The probability that the doctor diagnoses incorrectly that a person has TB, on the basis of the x-ray is 0.001. In a certain city, 1 in 10000 persons suffer from TB. A person selected at random is diagnosed to have TB. What is the probability that person has actually TB? [6]
3. Define hypergeometric distribution with an example. Describe the conditions for the binomial approximation to hypergeometric distribution. [2+3]
4. An instructor of a statistics class is planning to interview a sample of $n = 10$ students who are randomly selected from the class. The class has a total 30 students, consisting of 20 male and female students. [5]
- i) Determine the probability mass function of the number of female students in the sample.
 - ii) Find the probability that at least students is in sample.
 - iii) Find mean and variance for female students.
5. Define standard normal distribution. Give the condition for normal approximation to binomial distribution. [2+3]
6. Time taken to boot a computer is a continuous random variable x having pdf: [5]
- $$f(x) = kx(1-x), 0 < x < 1$$
- $$= 0, \text{ otherwise}$$
- Find i) $E(x)$
ii) $P(0.25 < x < 0.5)$
7. Define parameter and statistic with examples. Explain the central limit theorem. [5]
8. A population consists of the four numbers 5, 6, 9, 12. [5]
- i) Write down all possible sample size of two without replacement.
 - ii) Verify that the population mean is equal to the mean of the sample mean.
 - iii) Calculate the standard error of the sampling distribution of the sample mean.
9. What assumptions are of paired t-test? Write the process of paired t-test. [5]

10. Four brands of flashlight batteries are to be compared by testing each brand in five flashlights. Twenty flashlights are randomly selected and divided randomly into four groups of five flashlights each. Then each group of flashlights uses a different brand of battery. The lifetimes of the batteries, to the nearest hour, are as follows;

[5]

Brand A	Brand B	Brand C
42	36	28
28	36	38
24	32	28
20	39	32
30	31	28

At the 5% significance level, does there appear to be a significance difference in mean lifetime among the four brands of batteries.

11. Define type I and II error. A manufacturer claimed that at least 95% of the pumps supplied to the ABC Company confirmed to specifications. However, the production manager at ABC Company wasn't satisfied with the claim of the manufacturer. Hence, to test the claim, the manager examined a sample of 250 pumps supplied last month and found that 228 pumps as per the specifications. Can you conclude that the production manager is right to doubt on the claim of the manufacturer? ($\alpha = 0.01$)

[5]

12. Describe the hypothesis testing procedure of Chi-square test of independent for 2x2 table.

[5]

13. A computer operator is interested to know data rate of internet users depends upon the band width, the following result were gathered by the operator:

[5]

Band Width	17	35	41	19	25	20	10	15
Data rate	47	64	68	50	60	55	30	33

- Is there any association between band width and data rate?
 - Fit the regression model to describe the given data and also interpret the estimated regression coefficient.
 - Compute the band width when data rate is 62.
14. Define correlation and regression with examples. Write down the properties of correlation coefficient.
15. Randomly sampled 60 TU graduated BEs, half of whom majored in civil Engineering and half in Computer Engineering. From each, the highest salary offer (including benefits) is stated in following table:

[5]

Salary of Civil Engineering		Salary of Computer Engineering Graduates	
61,228	86,792	68,421	73,361
51,836	75,155	56,276	36,956
20,620	65,948	47,510	63,627
73,356	29,392	58,925	71,069
84,186	96,382	78,704	40,203
79,782	80,644	62,553	97,097
29,523	51,389	81,931	49,442
80,645	61,955	30,867	75,188
76,125	63,573	49,091	59,854
62,531	56,276	48,843	79,816
77,073	47,510	79,782	51,943
86,705	58,925	29,523	35,272
70,286	78,704	80,645	60,631
63,196	62,553	76,125	63,567
64,358	36,956	62,531	69,423

- Which of these groups shows consistency on the basis of salary offer?
- Find standard deviation of difference of average salaries of two groups.

[8]

TRIBHUVAN UNIVERSITY
INSTITUTE OF ENGINEERING
Examination Control Division
2078 Bhadra

Exam.	Regular		
	Level	BE	Full Marks
Programme	BEL, BEX, BCT, BAG	Pass Marks	32
Year / Part	III / I	Time	3 hrs.

Subject: - Probability and Statistics (SH 602)

- ✓ Candidates are required to give their answers in their own words as far as practicable.
- ✓ Attempt All questions.
- ✓ The figures in the margin indicate Full Marks.
- ✓ Necessary tables are attached herewith.
- ✓ Assume suitable data if necessary.

1. The number of minutes that a person had to wait for the bus to work on 13 working days are: 1, 10, 13, 12, 8, 2, 6, 9, 17, 30, 5, 4 and 15
 - a) Find the values constituting the 5 – number summary. [6]
 - b) Construct a box plot.
2. Worldlink, an internet service provider of Nepal buys, signal routers from three countries. It buys 22% of routers from America, 38% from India and 40% from China. It is found that 3% of routers from America, 4% of routers from India and 5% of routers from China are defective. If a customer buys one of these routers, what is the probability that
 - a) It is defective [6]
 - b) If the router is defective, it is from China. [5]
3. Compare Binomial and Negative Binomial Distributions. [5]
4. In a busy road of Kathmandu there were 500 vehicles passing from 8 AM to 6 PM. It was found that 2 in 1000 vehicle wrongly entered in a one way. Find the probability that at a particular day from 8 AM to 6 PM, there will be
 - a) No vehicle enter in one way
 - b) One vehicle enter in one way
 - c) At least one vehicle enter in one way
 - d) At most 2 vehicle enter in one way
 [5]
5. Define continuous random variable. Write the importance of Normal distribution with its area property. [5]
6. A random variable X has the probability density function f(x) as

$$f(x) = \begin{cases} kx e^{-\frac{x^2}{12}}, & x \geq 0 \\ 0, & \text{otherwise} \end{cases}$$
 - a) Find the value of k if f(x) is a probability density function. [5]
 - b) Find the mean and variance of random variable X.
7. Explain the following terms with suitable example
 - a) Parameters
 - b) Statistics
 - c) Standard error of statistics [5]
8. To illustrate that the mean of a random sample is an unbiased estimate of the mean of the population, consider five slips of paper numbered 3, 6, 9, 12, 15.
 - a) List all possible samples of size 3 that can be taken without replacement from this finite population.
 - b) Calculate the mean of each of the samples listed in
 - c) Verify that the sample mean is an unbiased estimate of the population mean [5]

9. The response time in milliseconds was determined for three different types of circuits in an electronic calculator. The results are shown in the following table.

Circuit Type	Response				
	A	19	22	20	18
B	20	21	33	27	40
C	16	15	18	26	17

Using $\alpha = 0.01$, test the hypothesis that the three circuit types have the same response time. ($F_{0.01, 2, 12} = 6.93$ $F_{0.01, 3, 12} = 6.70$)

[5]

10. Define Hypothesis and Write down the steps involve in the test of significance of difference of mean of large population.

[5]

11. Four hundred employees of Nepal Telecom are classified according to their level and decisions. Do you agree with the statement that decisions vary according to level of employee? Test at 5% level of significance.

[5]

Decisions	Sr. Officer	Officer	Jr. Officer	Total
Quick	60	80	70	210
Slow	40	60	90	190
Total	100	140	160	400

12. Consider the case of Pharmaceutical Manufacturing Company testing two new compounds intended to reduce blood-pressure level. The compounds are administered two different sets of laboratory animals. In groups A, 71 out of 100 animal tested response to drug first with lower blood-pressure levels. In group B, 58 out of 90 animals tested respond to drug second with lower blood pressure level. The company wants to test at 0.05 levels whether there is a difference between the efficiencies of these two drugs.

[5]

13. A sample of 10 values of the variables X_1 , X_2 and X_3 were obtained as

$\sum X_1 = 10$	$\sum X_2 = 20$	$\sum X_3 = 30$
$\sum X_1^2 = 20$	$\sum X_2^2 = 68$	$\sum X_3^2 = 170$
$\sum X_1 X_2 = 10$	$\sum X_1 X_3 = 15$	$\sum X_2 X_3 = 64$

Find Partial correlation between X_2 and X_3 eliminating the effect of X_1 also interpret coefficient of partial determination.

[5]

14. Fires and Acres Burned. Find the best predicted value of number of acres burned given that there were 80 fires

[5]

Fires	73	69	58	48	84	62	57	45
Acres burned	6.2	7.2	1.9	2.7	5.0	1.6	3.0	1.6

15. A semiconductor manufacturer produces devices used as central processing units in personal computers. The speed of the device (in megahertz) is important because it determines the price that the manufacturer can charge for the devices. The following table contains measurements on 48 devices.

[8]

717	727	653	637	660	693	679	682	724	642	704	695
704	652	664	702	661	720	695	670	656	718	660	648
683	723	710	680	684	705	681	748	697	703	660	722
662	709	683	705	678	674	656	667	683	691	750	685

Find the

- Sample mean of the distribution.
- Sample standard deviation and coefficient of variation.
- Standard error of sample mean.
- What percentage of the devices has a speed exceeding 700 megahertz?

TRIBHUVAN UNIVERSITY
INSTITUTE OF ENGINEERING
Examination Control Division
2076 Chaitra

Exam.	Regular		
Level	BE	Full Marks	80
Programme	BEL, BEX, ECT, BAG	Pass Marks	32
Year / Part	III / I	Time	3 hrs.

Subject: - Probability and Statistics (SH602)

- ✓ Candidates are required to give their answers in their own words as far as practicable.
- ✓ Attempt **All** questions.
- ✓ The figures in the margin indicate **Full Marks**.
- ✓ Necessary tables are attached herewith.
- ✓ Assume suitable data if necessary.

1. A professor of statistics, in his class with 20 students, had conducted a survey about time spent by students on social media, during college hours, and found average time of 20 minutes and standard deviation of 5 minutes. In subsequent verification, it was found that observation 30 was entered as 13. Then find corrected mean and standard deviation of time spent by the students on social media during college hours. [6]
2. Define mutually exclusive and independent events. An insurance company insured 2000 Civil engineers, 4000 Electrical engineers and 6000 Mechanical engineers. The probability of an accident involving Civil engineer, Electrical engineer and Mechanical engineer during their jobs is 0.01, 0.03 and 0.15 respectively. One of the insured engineers meets with an accident. What is the probability that he is civil Engineer? [6]
3. What are the characteristics of Binomial Distribution and how does it differ from Hypergeometric Distribution? [5]
4. If the probability that an individual suffers a bad reaction from a certain injection is 0.001, determine the probability that out of 2000 individuals
 - a) Exactly 3, individuals will suffer bad reaction
 - b) More than 2, individuals will suffer bad reaction
 [5]
5. If inner diameter of a rod follow Normal Distribution. If 7% of the rod has inner diameter less than 35 mm and 89% of rod has inner diameter fewer than 63 mm. Find the mean and the standard deviation of diameter of rods. [5]
6. Find the mean and variance of the probability density function given by

$$f(x) = \begin{cases} 12x^2(1-x); & 0 \leq x \leq 1 \\ 0 & ; \text{ otherwise} \end{cases}$$
 [5]
7. Define Standard error and explain its importance in inferential statistics and write down the formula of standard error of sample mean and sample proportion. [5]
8. A population consists of live numbers 4, 8, 12, 16 and 20. If a random sample of size 2 is drawn without replacement. [5]
 - a) Find the population mean and population standard deviation.
 - b) List the all possible sample and find their sample mean.
 - c) Show the mean of sample mean is equal to the population mean.
 - d) Find the standard error of sample mean.
9. Write the process of test of significance of difference of two means for large samples. [5]
10. The sales figure of an item in six shops before and after and advertisement is given as:

Before	53	28	31	48	50	52
After	58	29	30	55	56	45

 Test whether the advertisement was effective at 5% level of significance? [5]
(t-value for 5 degree of freedom = 2.571)

11. Dyson Company in Berlin plans to produce a new hair product known as Dyson Supersonic. The suppliers for the company are company A and Company B found that 1% and 2% defective of 200 and 300 items respectively. Arrange appropriate hypothesis testing to investigate whether Company B is better by using a 0.05 level of significance. [5]

12. In a recent survey 1650 Engineers were classified according to their intelligence (GPA in Bachelor) and economic conditions after graduation. Test whether there is any association between intelligence and economic condition. [χ^2 value for 9 degree of freedom=16.919] [5]

Economic Condition after graduation	Intelligence in BE			
	Excellent	Good	Mediocre	Dull
Good	48	199	181	82
Average	80	73	65	89
Below average	86	51	51	84
Not good	81	185	190	105

13. What are the two regression coefficients and what do they present? Write the properties of regression coefficients. [5]

14. Listed below are circumference (in feet) and height (in feet) of trees in Marshall. Minnesota (base on data from "Tree Measurement" by Stanley Rice, American Biology Teacher Vol 61. No 9) [5]

X(circ)	1.8	1.9	1.8	2.4	5.1	3.1	5.5	5.1	8.3
Y (ht)	21.0	33.5	24.6	40.7	73.2	24.4	40.4	45.3	53.5

- a) Is there a correlation exist?
 b) Explain this correlation.
15. The scores of randomly selected 32 students of two groups on Probability and Statistics are;

Group 'A'				Group 'B'			
50	37	13	37	56	74	50	43
45	9	11	34	39	24	55	35
24	6	13	24	72	32	45	59
32	32	24	40	47	36	34	32
33	45	37	38	40	53	55	18
33	32	46	32	32	42	49	32
46	21	32	4	41	33	14	60
45	16	43	32	60	34	38	48

- a) Which group is best?
 b) Which group is more consistent?
 c) Find standard error of difference of their means. [3+3+2]

TRIBHUVAN UNIVERSITY
INSTITUTE OF ENGINEERING
Examination Control Division
2076 Ashwin

Exam.	Back		
	Level	BE	Full Marks
Programme	BEL, BEX, BCT, BAG	Pass Marks	32
Year / Part	III / I	Time	3 hrs.

Subject: - Probability and Statistics (SH 602)

- ✓ Candidates are required to give their answers in their own words as far as practicable.
- ✓ Attempt All questions.
- ✓ The figures in the margin indicate Full Marks.
- ✓ Necessary tables are attached herewith.
- ✓ Assume suitable data if necessary.

1. Describe the strong and weak points of various measures of Central tendency. From the following frequency distribution find the range of income of middle 70% of the employees and the median income. Also find mean deviation from mean. [6]

Income in Rs.	500-600	600-700	700-800	800-900	900-1000
No. of employees	150	300	500	200	50

2. Distinguish between absolute and relative measures of dispersion. The running capacity of two horses is given below, state which is more consistent and why? [5]

Horse A	250	255	280	290	295	300
Horse B	280	282	290	295	298	295

3. If we the following probability density function. [5]

$$f(x) = \begin{cases} k(5+2x), & 2 \leq x \leq 4 \\ 0, & \text{otherwise} \end{cases}$$

Find the value of K and mean and variance of random variable X.

4. A random variable X has following probability function. [6]

X	-2	-1	0	1	2	3
P(X)	K	0.1	0.2	2k	3k	0.1

- i) Find the value of K.
ii) Find Mean and Variance.

5. During one stage in the manufacture of integrated circuit chips, a coating must be applied. If 70% of chips receive a thick enough coating, find the probability that among 15 chips (i) at least 12 will have thick enough coatings; (ii) at most 3 will have thick enough coatings; (iii) exactly 10 will have thick enough coatings. [5]

6. In a normal distribution 31% of the items are under 45 and 8% are over 64. Find the mean and standard deviation of distribution. (Given, $Z_{0.42}=1.4$, $Z_{0.19}=0.5$) [5]

7. Describe the advantages of sample surveys over complete enumeration? [6]

Nepal Electricity Authority wishes to estimate the average electric bills for the month of October for single family homes in Kathmandu. Based on similar studies in other cities the standard deviation is assumed to be Rs. 150. The NEA wants to estimate the average bill for October such that error will not deviate by Rs. 15 with 90% confidence. What sample size is needed?

8. What are the assumptions for the t-test? Describe the procedure of test of significance between two means for small sample. [5]

9. A research company has designed three different systems to clean up oil spills. The following table contains the results, measured by how much surface area in square meters is cleared in one hour. The data were found by testing each method in several trials. Are the three systems equally effective? Use the 0.05 level of significance. [5]

System A	55	60	63	56	59	55
System B	57	53	64	49	62	-
System C	66	52	61	57	-	-

10. Test of the fidelity and selectivity of 190 digital radio receivers produced the results shown in the following table.

Selectivity	Fidelity		
	Low	Average	High
Low	6	12	32
Average	33	61	18
High	13	15	0

Use $\alpha=0.05$ and $\chi^2 = 5.991$ to test whether there is relationship between fidelity and selectivity. [6]

11. Define Hypothesis, and write down the steps involve in the test of significance of difference of proportion. [5]
12. In 1990, 5.8% job applicants who were tested for drugs failed the test. At the 0.05 significant level, the test claim that the failure rate is now lower if a simple random sample of 1520 current job applicants results in 58 failure. Does the result suggest that fewer job applicants now use drugs? [5]
13. Fit the regression line of yield of crop ('000 tonnes) on amount of rainfall (mm) and amount of fertilizers used (kg). Also estimate the yield of crop for the year in which rainfall is 13 mm and fertilizer used is 9 kg. [5]

Yield	4	6	7	9	13	15
Rainfall	3	4	6	8	12	15
Fertilizer	4	10	14	20	24	30

14. The following data gives the experience of machine operators in years and their performance as given by the number of good parts turned out per 100 pieces.

Experience (X)	16	12	18	4	3	10	5	12
Performance (Y)	87	88	89	68	78	80	75	83

- a) Fit the regression equation of performance rating on experience and estimate the probable performance of an operator had 8 years experience. [5]
- b) Determine coefficient of determination and interpret it.
15. List Five Number summary and prepare the box plot for numbers of guest registered each of 60 randomly selected days. [6]

108	94	188	116	165	181	106	133	176	110
169	134	129	109	85	124	119	165	153	135
105	180	105	91	117	148	83	96	101	123
128	143	136	99	169	133	89	90	174	144
151	168	103	116	106	107	179	113	172	120
179	183	99	94	87	120	154	159	103	139

TRIBHUVAN UNIVERSITY
INSTITUTE OF ENGINEERING
Examination Control Division
2075 Chaitra

Exam.	Regular / Back		
	Level	BE	Full Marks
Programme	BEL, BEX, BCT, BAG	Pass Marks	32
Year / Part	III / I	Time	3 hrs.

Subject: - Probability and Statistics (SH 602)

- ✓ Candidates are required to give their answers in their own words as far as practicable.
- ✓ Attempt All questions.
- ✓ The figures in the margin indicate Full Marks.
- ✓ Necessary tables are attached herewith.
- ✓ Assume suitable data if necessary.

1. Write down the significance of statistics in engineering. An experiment shows the height of 51 plants given below. If average heights of all the 51 plants are 40 cm find the missing frequencies corresponding to the height 30 and 50cm. [6]

Height (cm)	10	20	30	40	50	60
No. of plant	2	3	-	21	-	5

2. What do you mean by mutually exclusive, exhaustive and complementary events? Explain with examples. In a particular city, airport A handles 50% of all airlines traffic, airport B handles 30% and airport C handles 20%. The detection rates for weapons at the three airports are 0.9, 0.5 and 0.4 respectively. A passenger is randomly selected at one of the airports. Then (i) what is the probability that he/she carrying a weapon? (ii) If he/she is found to be carrying a weapon, what is the probability that airport A is being used? [5]
3. Define probability density function? A continuous probability distribution of a variable x is defined as $f(x) = KX(1-X)$ for all $0 \leq X \leq 1$. Compute (i) $P(X \geq 0.4)$ (ii) $P(\frac{1}{4} \leq X \leq \frac{3}{4})$ [5]
- Or,
- A fair dice was rolled until one gets a Six; find the expected number of toss required?
4. Define Negative Binomial distribution and explain characteristics. How does it differ from binomial distribution? [6]
5. A typist made 2.6 mistakes per page on average, find the probability that in the page typed by him, i) there is no mistake ii) at least two mistakes iii) at most 3 mistakes. [5]
6. Define Gamma distribution, chief characteristics and write its applications. [5]

Or,

The breakdown voltage X of randomly chosen diode of a particular type is known to be normally distributed with mean 40 and s.d. 1.5 volts. What is the probability that the breakdown voltage will be (a) between 39 and 42 volts; (b) at most 43 volts; (c) at least 39 volts.

7. Define estimation? Write characteristics of a good estimator? A sample of 400 students taking Entrance for BE revealed an average score of 56. Construct a 95% as well as 99% confidence interval for population mean score if standard deviation of score of all students is known to be 10. [6]
8. A whole sale dealer wanted to buy a large quantity of light bulbs from two brands label A and B. He bought 100 bulbs from each bulbs brand and found by testing that brand A had mean life time 1120 hours and standard deviation 75 hours and brand B had mean life

time 1062 hours and standard deviation 82 hours. Find the 95% and 99% confidence limits for the difference in the average life of bulbs from the two brands. [5]

9. The following are the breaking strength of three different brands of cables.

Brand	Breaking Strength					
A	40	30	50	60	30	-
B	60	40	55	65	-	-
C	60	50	70	65	75	40

Construct ANOVA table and test for the equality of the average breaking strength of cables at $\alpha=5\%$. [5]

10. In a recent survey 1,072 Engineers were classified according to their intelligence (GPA in Bachelor) and economic conditions after graduation. Test whether there is any association between intelligence and economic condition. [6]

Economic Condition after graduation	Intelligence in BE			
	Excellent	Good	Mediocre	Dull
Good	48	199	181	82
Not good	81	185	190	106

χ^2 value for 2 d.f.=5.991

11. What is testing of hypothesis? Explain the procedure followed in testing of Significance difference between two population proportion large sample? [5]

12. A simple random sample of Household with TV set in use. Show that 1024 of them were tuned to 60 minute while 3836 were tuned to some other show. Use 0.05 significant level to test the claim of CBS executive that "60 minute get more than a 20 shave", which mean that more than 20% of set in use are tuned to 60 minute. [5]

13. A sample of 10 values of three variables X_1 , X_2 and X_3 were obtained as

$\Sigma X_1=10$	$\Sigma X_2=20$	$\Sigma X_3=30$
$\Sigma X_1^2=20$	$\Sigma X_2^2=68$	$\Sigma X_3^2=170$
$\Sigma X_1X_2=10$	$\Sigma X_1X_3=15$	$\Sigma X_2X_3=64$

Find (i) Partial correlation between X_1 and X_2 eliminating the effect of X_3 (ii) Multiple correlation between X_1 , X_2 and X_3 assuming X_1 as dependent variable. [5]

14. Differentiate between correlation and regression? From following data find the Karl Pearsons coefficient correlation and interpret the result? [5]

Marks in Statistics	39	65	62	90	82	75	25	98	36	78
Marks in Mathematics	47	53	58	86	62	68	60	91	51	84

15. Following data reveals the sample of 22 pairs of observation (X,Y) drawn from large population.

X	46	61	56	68	58	45	50	59	45	66	57
Y	49	46	43	32	26	27	29	47	37	30	43
X	59	66	62	57	57	45	50	61	55	47	51
Y	32	27	37	24	43	49	48	29	37	32	26

- Find the sample mean for each variable X and Y.
- Which series is more consistent and why?
- Find the standard error of the difference of mean.
- Find the coefficient of Karl Pearson correlation.

[6]

Exam.	Back		
Level	BE	Full Marks	80
Programme	BEL, BEX, BCT, B.Agri.	Pass Marks	32
Year / Part	III / I	Time	3 hrs.

Subject: - Probability and Statistics (SH602)

- ✓ Candidates are required to give their answers in their own words as far as practicable.
- ✓ Attempt All questions.
- ✓ The figures in the margin indicate Full Marks.
- ✓ Necessary tables are attached herewith.
- ✓ Assume suitable data if necessary.

1. Define measures of central tendency and measures of variance. Following data gives the distribution of marks of 50 students in statistics.

Marks more than	10	20	30	40	50	60	70
No. of students	50	45	35	20	10	4	1

Compute median marks. Also compute minimum marks obtained by a pass candidate if 60% student pass in the test. [6]

2. A problem in statistics is given to three students A, B and C whose chances of solving are $\frac{1}{2}$, $\frac{3}{4}$ and $\frac{1}{4}$ respectively. If all of them try independently, what is the probability that

- a) at least one of them will solve it
- b) none of them can solve it
- c) exactly two of them can solve it

[6]

3. Define binomial distribution and explain the condition for Binomial distribution. [2+2]

4. If the probability that an individual suffers a bad reaction from a certain injection is 0.001, among 2000 individual

- a) obtain probability distribution function for suffering bad reaction
- b) determine the probability that
 - (i) exactly 3 individuals will suffer bad reaction
 - (ii) more than 2, individuals will suffer bad reaction

[6]

5. The breakdown voltage x of randomly chosen diode of a particular type is known to be normally distributed with mean 40 and standard deviation 1.5 volts. What is the probability that the breakdown voltage. Will be

- a) Between 39 and 42 Volts
- b) At most 43 Volts
- c) At least 39 Volts

[6]

OR

The distribution function for a random variable x is

$$f(x) = 1 - e^{-2x} \text{ for } x \geq 0$$

$$= 0 \text{ for } x < 0$$

- a) Find $p(x > 2)$
- b) Find mean and variance of the variable x .

6. Define discrete and continuous random variable. Also describe the procedure to compute mean and variance for both variables. [4]
7. Define standard normal distribution. Write down its properties and importance of this distribution. [4]
8. A population consists of four number 2, 8, 14, 20,
 a) Write down all possible sample size of two without replacement. [6]
 b) Verify that the population mean is equal to the mean of the sample mean.
9. What are difference between point estimation and Interval estimation? Also discuss differences between estimation and Hypothesis testing. [3+3]
10. Define critical value. A manufacturer claimed that at least 95% of the water pumps supplied to the ABC Company confirmed to specification. However, the product manager at ABC Company wasn't satisfied with the claim of the manufacturer hence to test the claim, the manager examined a sample of 250 water pumps supplied last month and found that 228 water pumps 45 per the specification. Can you conclude that the production manager is right to doubt on the claim of the manufactures ($\alpha = 0.01$) [6]
11. Three varieties of coal were analyzed by four chemists and the ash-content in the varieties were found as follows:

Varieties	Chemists			
	1	2	3	4
A	8	5	5	7
B	7	6	4	4
C	3	6	5	4

Test whether the varieties differ significantly in their ash-content? Test at 5% level of significance.

$$[F_{(2,9)} = 19.4, \quad F_{(3,9)} = 8.81].$$

12. Write the procedure of testing of Hypothesis for single proportion. [6]
[4]
13. The following data gives the number of twists required to break a certain kind of forged alloy bar and percentage of alloying element A present in the metal

Number of twists	41	49	69	65	40	50	58	57	31	36
Percentage of elements A	10	12	14	15	13	12	13	14	13	12

- a) Fit the regression equation of number of twists on percentage of element A. Determine the predicted number of twists required break an alloy when percentage of element is 20 [4]
- b) Find 99% confidence interval for the regression coefficient. [4]
14. The simple correlation coefficient between fertilizer (x_1) seeds (x_2) and productivity (x_3) are $r_{12} = 0.59$, $r_{13} = 0.46$ are $r_{23} = 0.77$ calculate the partial correlation coefficient $r_{12.3}$ and multiple correlation $R_{1.23}$ [4]

15. The samples of length of life of bulbs from two companies are given below.

[8]

Length of life (hours)	Company	
	A	B
500-600	10	3
600-700	21	8
700-800	6	15
800-900	8	12
900-1000	21	4
1000-1100	10	5
1100-1200	2	15
1200-1300	12	13
1300-1400	19	7
1400-1500	9	7
1500-1600	3	4
1600-1700	7	6
1700-1800	5	3
1800-1900	4	2
1900-2000	1	3

- Calculate mean length of life of bulbs from company A and company B
- Calculate sample standard deviation and sample variance for given data
- Which company is bulbs are more uniform?

Table A3: Chi-squared Distribution

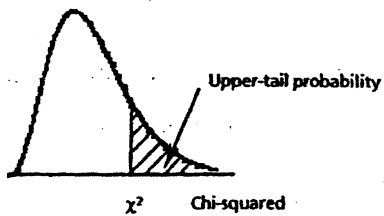

df	Upper Tail Probabilities					
	0.99	0.975	0.95	0.05	0.025	0.01
	Values of Chi-squared					
1	0.0002	0.0010	0.004	3.84	5.02	6.63
2	0.020	0.051	0.103	5.99	7.38	9.21
3	0.11	0.22	0.35	7.81	9.35	11.34
4	0.30	0.48	0.71	9.49	11.14	13.28
5	0.55	0.83	1.15	11.07	12.83	15.09
6	0.87	1.24	1.64	12.59	14.45	16.81
7	1.24	1.69	2.17	14.07	16.01	18.48
8	1.65	2.18	2.73	15.51	17.53	20.09
9	2.09	2.70	3.33	16.92	19.02	21.67
10	2.56	3.25	3.94	18.31	20.48	23.21
11	3.05	3.82	4.57	19.68	21.92	24.73
12	3.57	4.40	5.23	21.03	23.34	26.22
13	4.11	5.01	5.89	22.36	24.74	27.69
14	4.66	5.63	6.57	23.68	26.12	29.14
15	5.23	6.26	7.26	25.00	27.49	30.58
16	5.81	6.91	7.96	26.30	28.85	32.00
17	6.41	7.56	8.67	27.59	30.19	33.41
18	7.01	8.23	9.39	28.87	31.53	34.81
19	7.63	8.91	10.12	30.14	32.85	36.19
20	8.26	9.59	10.85	31.41	34.17	37.57
21	8.90	10.28	11.59	32.67	35.48	38.93
22	9.54	10.98	12.34	33.92	36.78	40.29
23	10.20	11.69	13.09	35.17	38.08	41.64
24	10.86	12.40	13.85	36.42	39.36	42.98
25	11.52	13.12	14.61	37.65	40.65	44.31
26	12.20	13.84	15.38	38.89	41.92	45.64
27	12.88	14.57	16.15	40.11	43.19	46.96
28	13.56	15.31	16.93	41.34	44.46	48.28
29	14.26	16.05	17.71	42.56	45.72	49.59
30	14.95	16.79	18.49	43.77	46.98	50.89
35	18.51	20.57	22.47	49.80	53.20	57.34
40	22.16	24.43	26.51	55.76	59.34	63.69
45	25.90	28.37	30.61	61.66	65.41	69.96
50	29.71	32.36	34.76	67.50	71.42	76.15

		REGULAR	
Level	BE	Full Marks	80
Programme	BEL, BEX, BCT, B.Agri.	Pass Marks	32
Year / Part	III / I	Time	3 hrs.

Subject: - Probability and Statistics (SH602)

- ✓ Candidates are required to give their answers in their own words as far as practicable.
- ✓ Attempt All questions.
- ✓ The figures in the margin indicate **Full Marks**.
- ✓ Necessary tables are attached herewith.
- ✓ Assume suitable data if necessary.

1. What are measures of central tendencies? Write favorable points of each of them. Calculate approximate measures of central tendency from following data; [1+2+3]

Wages in Rs/ week	Less than 35	35-37	38-40	41-43	Over 43
No. of wage earned	14	82	99	18	7

2. From a group of 4 Engineers, 3 Doctors and 2 Statistician a sub-group of 3 has to be made, what is the probability that sub-group consists of [4]
- a) One from each profession
 - b) Atleast one engineer
3. Define discrete probability distribution with suitable example. Compare Negative Binomial and Binomial probability distributions. [3+3]
4. A quality control engineers inspects a random sample of 3 batteries from each lot of 24 car batteries that is ready to shipment. If such a lot contain six batteries with slight defects, what is the probabilities that the inspector's sample will contain [6]
- a) None of the batteries with defect
 - b) Only one of the batteries with defect
 - c) At least two of the batteries with defect
5. Write major characteristics of normal distribution. Discuss relation between Normal distribution and Standard Normal distribution. [2+3]

OR

What are Gamma and Chi-squared distributions? Specify relationship between them.

6. The life of an electric light bulbs follows Normal distribution with mean 800 hours and a standard deviation of 50 hours. Find the probability that a bulb burns [5]
- a) Between 750 and 825 hours
 - b) More than 900 hours

OR

Define exponential distribution. Suppose that the service life of a semiconductor is exponentially distributed with an average of 60 hours. Find the probability that a semiconductor will a) still working after 90 hours
 b) fail within 120 hours

7. A population consists of five numbers 2, 4, 6 and 8 [4]
- a) Enumerate all possible sample of size two without replacement
 - b) Show that the mean of the sampling distribution of sample mean is equal to population mean

8. State central limit theorem. A random sample of size 100 is taken from an infinite population with mean 75 and variance 256. Assert the chances of sample mean between 67 and 83. [6]

9. What is type I error? Describe the procedure of the for difference of two Mean for large sample. [6]

10. Define chi-square distribution. A book containing 500 pages, was thoroughly checked. The distribution of number of error page was given below as

Number of errors:	0	1	2	3	4	5
Number of pages:	275	138	75	7	4	1

Using chi-square test of goodness of fit, verify whether the arrivals follow a poisson distribution at 5% level of significance. [6]

11. Define hypothesis. Describe the procedure of testing of hypothesis of significant difference between two population means for large samples.

OR

Describe the types of error in Hypothesis Testing. Write the procedure testing of Hypothesis of single proportion. [6]

12. Write the Decision criteria in test of Hypothesis with diagram. [4]

13. In trying to evaluate the effectiveness of antibiotics in killing bacteria, a research institute compiled the following information

Antibiotics (mg)	12	15	14	16	17	10
Bacteria	5	7	5.6	7.2	8.6	6.2

Find strength and direction of relationship between them. [4]

14. Differentiate between Correlation and regression analysis. [4]

15. Following data reveals the scores of sixty candidates of IOE entrance examination

51.43	40	78.57	46.43	51.43	50.71
42.14	50.71	42.86	55	71.43	64.29
52.86	42.14	57.14	45.71	43.57	40
44.29	55.71	40	48.57	48.57	49.29
51.43	47.14	54.29	45	53.57	50
49.29	60	48.57	50.71	50	49.29
47.14	53.57	58.57	43.57	47.14	53.57
47.86	47.14	40	43.57	52.86	47.86
49.29	49.29	42.86	47.14	48.57	50
47.14	50.71	52.86	47.86	47.14	70

- Estimate average score of candidates
- Find unbiased estimator of true standard deviation and standard error of average score
- Also test for consistency of score

[8]

Exam.	Back		
Level	BE	Full Marks	80
Programme	BEL, BEX, BCT, B. Agri.	Pass Marks	32
Year / Part	III / I	Time	3 hrs.

Subject: - Probability and Statistics (SH602)

- ✓ Candidates are required to give their answers in their own words as far as practicable.
- ✓ Attempt All questions.
- ✓ The figures in the margin indicate Full Marks.
- ✓ Necessary tables are attached herewith.
- ✓ Assume suitable data if necessary.

1. What is Box plot and what does it measure? Explain the meaning of its different parts with diagram.

A civil engineering monitors water quality by measuring the amount of suspended solids in a sample of river water. Over 11 weekdays, he observed 14, 12, 21, 28, 30, 63, 29, 65, 55, 19, 20 suspended solids (parts per million).

Find the third quartile and interpret its meaning.

[3+3]

2. Write down the difference between the sample space and sample points, dependent and independent events. Urn A contains 2 white 1 black and 3 red balls. Urn B contains 3 white 2 black and 4 red balls. Urn C contains 4 white 3 black and 2 red balls. One Urn is chosen at random and 2 balls are drawn. They happen to be red and black. What is the probability that both come from Urn B.

[6]

3. What are the characteristics of Binomial Distribution and how does it differ from Negative Binomial Distribution?

[4]

4. A quality control engineer inspects a random sample of 4 batteries from each lot of 24 car batteries that is ready to shipment. If such a lot contains six batteries with slight defects. What are the probabilities that the inspector's sample will contain.

[5]

i) None of the batteries with defect?

ii) At least two of the batteries with defects?

iii) At most three of the batteries with defects?

5. The breakdown voltage X of a randomly chosen diode of a particular type is known to be normally distributed with mean 40 volts and variance 2.25 volts. What is the probability that the breakdown voltage will be

[5]

i) Between 39 and 42 volts

ii) Less than 44 volts

iii) More than 43 volts

OR

The daily consumption of electric power in a certain city follows a gamma distribution with $\alpha = 2$ and $\beta = 3$. If the power plant of this city has a daily capacity of 12 million kilowatt hours, what is the probability that this power supply will be inadequate on any given day?

6. A college professor never finishes his lecture before the bell rings to end the period and always finishes his lectures within one minute after the bell rings. Let X = the time which elapses between the bell and the end of the lecture. Suppose that the p.d.f of X is [5]

$$f(x) = kx^2, 0 \leq x \leq 1$$

$$= 0, \text{ otherwise}$$

- i) Find the value of k
 ii) What is the probability that the lecture ends with $\frac{1}{2}$ minute of the bell ringing?
 iii) What is the probability that the lecture continues beyond the bell for between 15 and 30 seconds?
7. Define Central Limit Theorem. The amount of impurity in a batch of a certain chemical product is a random variable with mean value 4.0 gm and standard deviation 1.5 gm. If 50 batches are independently prepared, what is the probability that the sample average amount of impurity is between 3.5 and 3.8 gm? [5]
8. Define population. Sample parameter and statistic with suitable examples. A population consists of 3, 7, 11, 15. Consider all possible samples of size two which can be drawn without replacement from this population. Find population mean and Standard error of mean. [6]
9. What are the two regression coefficients and what do they represent when these two will be same? Write any three properties of regression coefficient. [5]
10. A sample of 8 values of three variables X_1, X_2 and X_3 were obtained as [5]

$\Sigma X_1 = 360$	$\Sigma X_2 = 64$	$\Sigma X_3 = 48$
$\Sigma X_1^2 = 17172$	$\Sigma X_2^2 = 546$	$\Sigma X_3^2 = 320$
$\Sigma X_1 X_2 = 2845$	$\Sigma X_1 X_3 = 2269$	$\Sigma X_2 X_3 = 396$

Find:

- i) Partial correlation between X_1 and X_3 eliminating the effect of X_2
 ii) Multiple correlation between X_1, X_2 and X_3 assuming X_3 as dependent
11. Discuss difference between estimation and hypothesis test of significance of population [5]

66.3	63.5	64.9	61.9	64.3	64.7	65.1	64.5	68.4	63.2
------	------	------	------	------	------	------	------	------	------

Find 99% confidence interval for true hardness of magnesium alloy.

12. An examination was given to 50 students at college A and 60 students at college B. At a mean grade was 75 with standard deviation of 9. At B mean grade was 79 with a standard deviation of 7. Is there significant difference between the performance of students at A and those at B, given that $\alpha = 0.05$? [6]

OR

Three randomly selected groups of chickens are fed on three different diets. Each group consists of five chickens. Their weight gains during a specified period of time are as follows:

Diet I	4	4	7	7	8
Diet II	3	4	5	6	7
Diet III	6	7	7	7	8

Test the hypothesis that mean gains of weight due to the three diets are equal.

Exam.	Regular		
Level	BE	Full Marks	80
Programme	BEL, BEX, BCT, B. Agri	Pass Marks	32
Year / Part	III / 1	Time	3 hrs.

Subject: - Probability and Statistics (SH602)

- ✓ Candidates are required to give their answers in their own words as far as practicable.
- ✓ Attempt All questions.
- ✓ The figures in the margin indicate Full Marks.
- ✓ Necessary tables are attached herewith.
- ✓ Assume suitable data if necessary.

1. Describe the various measures of central tendency and its application. The following table represents the marks of 100 students. [6]

Marks	0-20	20-40	40-60	60-80	80-100
No. of students	14	18	27	26	15

Find the mean, median and standard deviation of all 100 students.

2. Explain Baye's theorem. A chain of video stores sells three different brands of DVD players; Of its DVD players sales, 50% are brand 1 (the least expensive), 30% are brand 2, and 20% are brand 3. Each manufacturer offers a 1-year warranty on parts and labor. It is known that 25% of brand 1's DVD players require warranty repair work, where as the corresponding percentages for brands 2 and 3 are 20% and 10%, respectively. [2+4]
- What is the probability that a randomly selected purchaser has bought a brand 1 DVD players that will need repair while under warranty?
 - What is the probability that a randomly selected purchaser has a DVD player that will need repair while under warranty?
3. Define negative binomial distribution with its important characteristics. [5]
4. If a publisher of nontechnical books takes great pains to ensure that its books are free of typographical errors, so that the probability of any given page containing at least one such error is 0.005 and errors are independent from page to page, what is the probability that one of its 400-page novels will contain. [5]
- Exactly one page with errors?
 - At most three pages with errors?
5. In a certain examination test 2000 students appeared in Statistics. The average marks obtained were 50% and the standard deviation was 5%. How many students do you expect to obtain more than 60% marks? What are the minimum marks of the top 100 students? Assume that the marks are normally distributed. [5]

OR

The daily consumption of water in a certain place follow a gamma distribution with parameters $\alpha = 2$ and $\beta = 3$. If the daily capacity of this city is 9 million gallon of water, what is the probability that on any given day the water supply is inadequate?

6. The distribution function of a random variable x is [5]

$$F(x) = 1 - e^{-2x} \text{ for } x \geq 0$$

$$= 0 \text{ for } x < 0$$

- Find $P(x > 2)$
- Find mean and variance of the variable x .

7. What do you mean by central limit-theorem and discuss its applications. [4]
8. An electrical firm manufactures light bulbs that have a length of life that is approximately normally distributed with mean equal to 800 hours and standard deviation of 40 hours. Find the probability that a random sample of 16 bulbs will have an average life of (a) less than 850 hours (b) between 750 to 900. [6]
9. Define partial and multiple correlation with suitable examples. Write down the properties of partial and multiple correlation. [5]
10. Raw material used in the production of a synthetic fiber is stored in a place which has no humidity control. Measurements of the relative humidity in the storage place and moisture content of sample of the raw material (both in percentage) on 12 days yielded the following results: [5]

Humidity, X	42	35	50	43	48	62	31	36	44	39	55	48
Moisture content, Y	12	8	14	9	11	16	7	9	12	10	13	11

Verify that it is reasonable to fit a straight line. Fit the straight by the method of least squares.

11. Describe the procedure of the test of significance for difference of two properties for large sample. [5]
12. Six sample of each of four types of cereal grain grown in a certain region were analyzed to determine thiamin content, resulting in the following data (mg/g): [5]

Wheat	5.2	4.5	6.0	6.1	6.7	5.8
Barley	6.5	8.0	6.1	7.5	5.9	5.6
Maize	5.8	4.7	6.4	4.9	6.0	5.2
Oats	8.3	6.1	7.8	7.0	5.5	7.2

Does this data suggest that at least one of the grains differ with respect to true average thiamin content? Use 0.05 level of significance.

OR

A liquid dietary product implies in its advertising that use of the product for one month results in an average weight loss of at least 3 pounds. Eight subjects use the product for one month, and the resulting weight loss data are reported below. Do the data support the claim of the producer of the dietary product with the probability of a type I error set to 0.05?

Subjects	1	2	3	4	5	6	7	8
Weight (lb)	165	201	195	198	155	143	150	187
Weight (lb)	161	195	192	193	150	141	146	183

13. From the following data can you conclude that there is association between the purchase of brand and geographical region? [5]

	Region		
	Central	Eastern	Western
Purchase brand	40	55	45
Do not purchase brand	60	45	55

Use 5% level of significance.

14. Two different areas of a city are being considered as sites for day-care centers. Of 200 households surveys in one section, the proportion in which the mother worked full-time was 0.52. in another section, 40% of 150 households surveyed had mothers at full time jobs. At 0.05 level of significance, is there a significant difference in the proportion of working mothers in the two areas of the city? [5]

P.T.O →

Exam.	New Back (2066 & Later Batch)		
Level	BE	Full Marks	80
Programme	BEL, BEX, BCT, B. Agri.	Pass Marks	32
Year / Part	III / I	Time	3 hrs.

Subject: - Probability and Statistics (SH602)

- ✓ Candidates are required to give their answers in their own words as far as practicable.
- ✓ Attempt All questions.
- ✓ The figures in the margin indicate Full Marks.
- ✓ Necessary tables are attached herewith.
- ✓ Assume suitable data if necessary.

1. In two companies A and B engaged in similar type of industry, the average weekly wage and standard deviation are given below: [6]

	Company A	Company B
Average weekly wage (Rs)	460	490
Standard deviation	50	40
No. of wage earners	100	80

- i) Which company pays larger amount as weekly wags?
 - ii) Which company show greater variability in the distribution weekly wages?
 - iii) What is the mean and standard deviation of all the workers in two companies taken together?
2. State the law multiplication of probability. An Electronics company has an engineering position open. The Probability that an applicant is capable is 0.7. Each applicant is given written test and oral examination. A capable applicant passes with Probability 0.9 while an incapable applicant passes with Probability of 0.4. Find (a) the probability that an applicant passes the test (b) the probability that the applicant is capable given he/she passes the test. [6]
3. Define negative Binominal Distribution. If a boy is throwing stone at a target what is the probability that his 10th throw is his 5th hit, if the probability of hitting the target at any trial is 0.6. Also find the mean and variance of random variable. [5]
4. Define hypergeometric probability distribution with an example. Describe the conditions for the binomial approximation to hypergeometric distribution? [5]
5. Let X denote the amount of time for which a book on two hour reserve at a college library is checked out by a randomly selected student and suppose that X has density function, [5]
- $$f(x) = \begin{cases} 1/2x, & 0 \leq x \leq 2 \\ = 0 & \text{otherwise} \end{cases}$$
- Calculate $P(X \leq 1)$ and $P(0.5 \leq X \leq 1.5)$
6. Define continuous random variable with suitable example. Describe the properties of probability density function and distribution function. [5]
7. State Central limit theorem with an example. Explain why it is important in engineering field? [5]
8. A population consists of the four number 2,8,14,20 [5]
- i) Write down all possible sample size of two without replacement
 - ii) Verify that the population mean is equal to the mean of the sample mean
 - iii) Calculate the standard error of the sampling distribution of the sample mean
9. Define Karl Person coefficient of Correlation and coefficient of determination. What it is input in analysis. [5]

10. A house survey on monthly expenditure on food yield following data:

[5]

Monthly expenditure (100 Rs.)	10	15	20	25	30	35	40
Monthly income (1000 Rs.)	2	4	5	7	6	6	5
Size of the family	4	5	7	10	8	11	4

Obtain the multiple correlation coefficient.

11. There was a research on voltage supply by Ba Hries supplied by two companies. Both company claims that same. But researcher suspects that there is significance difference between mean voltages between two companies. To test this, she selected independent samples from both company and in lab test the result were as follows:

[5]

		Mean	Sample Standard deviation
Company A	13	3.59V	0.3V
Company B	10	3.15V	0.4V

Test the researcher suspect was correct at 5% level of significance.

12. Shyam and Co. produces three varieties of certain product: deluxe, find and ordinary. A recent market survey is conducted for preference of products. The preference was found as follow:

[5]

Product	Production			
	Deluxe	15	14	19
Fine	17	12	20	16
Ordinary	16	18	16	17

Is there a significant difference in the preference of products test it using ANOVA test. Use $\alpha = 5\%$

OR

The following are the average weekly losses of worker hours due to accidents in 10 industrial plan before and after a certain safety program was put into operation:

Before	45	73	46	124	33	57	83	34	26	17
After	36	60	44	119	35	51	77	29	24	11

Use the 0.05 level of significance to test whether the safety program is effective.

13. Define critical value. A manufacturer claimed that at least 95% of the water pumps supplied to the ABC Company confirmed to specification. However, the product manager at ABC Company wasn't satisfied with the claim of the manufacturer. Hence, to test the claim, the manager examined a sample of 250 water pumps supplied last month and found that 228 water pumps as per the specification. Can you conclude that the production manager is right to doubt on the claim of the manufactures? ($\alpha=0.01$)

[5]

14. Describe the Hypothesis testing procedure of Chi-square test of independence for 2×2 table.

[5]

15. The following table shows the number of hours 45 hospital patients slept following the administration of a certain anesthetic.

[8]

7	10	12	4	8	7	3	8	5
12	11	3	8	1	1	13	10	4
4	5	5	8	7	7	3	2	3
8	13	1	7	17	3	4	5	5
3	1	17	10	4	7	7	11	8

- a) Find sample mean, sample variance and sample standard deviation
b) Compare a value that measures the amount of variability relative to the value of mean

Exam.	Regular		
Level.	BE	Full Marks	80
Programme	BEL, BEX, BCT B. Agri.	Pass Marks	32
Year / Part	III / I	Time	3 hrs.

Subject: - Probability and Statistics (SH602)

- ✓ Candidates are required to give their answers in their own words as far as practicable.
- ✓ Attempt All questions.
- ✓ The figures in the margin indicate **Full Marks**.
- ✓ Necessary tables are attached herewith.
- ✓ Assume suitable data if necessary.

1. What are the differences between measures of central-tendency and measures of dispersion? The mean and standard deviation of 20 items is found to be 10 and 2 respectively. At the time of checking it was found that one item 8 was incorrect. Calculate the mean and standard deviation if: (i) the wrong item is omitted (ii) it is replaced by 12. [6]
2. Define conditional probability. An assembly plant receives its voltage regulators from these three different suppliers, 60% from supplier A, 30% from supplier B, and 10% from supplier C. It is also known that 95% of voltage regulators from A, 80% of these from B, and 65% these from C perform according to specifications. What is the probability that [6]
 - i) Anyone voltage regulator received by the plant will perform according to specifications
 - ii) A voltage regulator that perform according to specification came from B
3. Write the differences and similarities between Binomial and Negative Binomial Distribution. [2+3]
4. In certain factory turning out optical lenses, there is a small change, 1/500 for any lens to be defective. The lenses are supplied in packets of 10 each. What is the probability that a packet will contain [5]
 - i) No defective lens
 - ii) At least one defective lenses
 - iii) At most two defective lenses

OR

Define mathematical expectation of a discrete random variable. A probability distribution is given.

X = x	0	1	2	3	4	5
p(X=x)	0.26	0.25	0.11	0.02	0.25	0.11

Find (a) $P(X \geq 4)$; (b) $p(0 < X < 4)$; (c) mean and variance of X

5. Define standard normal distribution. Give the condition for normal approximation of Poisson distribution. [5]
6. The mean inside diameter of a sample of 200 washers produced by a machine is 0.502 cm and the standard deviation as 0.005 cm. The purpose for these washers are intermed allows a maximum tolerance in the diameter of 0.496 to 0.508 cm, otherwise the washers are considered defective. Determine the percentage of defective washers produced by the machine. Assume the diameter is normally distributed. [5]
7. What do you mean by sampling distribution of a sample mean and its Standard Error? Explains with example. What would be the variance of sampling distribution of mean, if sample is taken from finite population? [5]

8. Define the Central Limit Theorem. A sample of 100 mobile battery cells tested to find the length of life produced the following results as mean 13 months and standard deviation of 3 months. Assuming the data to be normally distributed by using Central Limit Theorem what percentage of battery cells expected to have Average life? [5]

i) More than 15 months (ii) Less than 9 months

9. Define partial and multiple correlations with examples. Write down the properties of partial and multiple correlation. [5]

10. An article in wear (Vol.152, 1992, pp. 171-181) presents data on the fretting wear of mild steel and oil viscosity. Representative data follow, with x = oil viscosity and y = wear volume (10^{-4} cubic millimeters). [5]

y	240	181	193	155	172	110	113	75	94
x	1.6	9.4	15.5	20.0	22.0	35.5	43.0	40.5	33.0

i) Fit the sample linear regression model using least
ii) Predict fretting wear when viscosity $x = 30$

11. Describe the procedure of the test of significance for difference of two population mean for large sample. [5]

12. Ten objects were chosen at random from the large population and their weights were found to be in grams 63, 63, 64, 65, 66, 69, 65, 66.1, 64.5. In the light of above data, discuss the suggestion that the mean weight in the population is 65 gm. Use $\alpha = 0.05$. [5]

13. Define chi-square distribution. From the following data can you conclude that there is association between the purchase of brand and geographical region? (Use 5% level of significance). [5]

	Region		
	Central	Eastern	Western
Purchase brand	40	55	45
Do not purchase brand	60	45	55

14. In a postal survey of 500 households, 330 said that they thought they were being overcharged for the public services within their area. [5]

i) Calculate an approximate 99% confidence interval for the population proportion, p , of households who thought they were being overcharged for public services within their area.

ii) Estimate the size of sample required to estimate the value of p to be within 99% confidence limits of ± 0.025 .

15. Following data gives the sample records of number of passenger take ticket at the counter of Bus during one hour period. [8]

22	58	32	36	62	57	25	45	23	37
64	56	46	60	29	49	63	36	26	58
60	26	58	58	29	43	53	36	45	22
52	43	45	31	45	39	35	38	30	60
58	42	54	62	52	42	65	58	51	60
53	45	31	53	22	53	51	52	47	59

Find the

- i. Sample mean of Number of passenger
- ii. Sample Standard deviation and Coefficient of variation.
- iii. Standard error of the sample mean.
- iv. Find the 95% and 99% confidence limit of sample mean

Exam.	New Back (2066 & Later Batch)		
Level	BE	Full Marks	80
Programme	BEL, BEX, BCT B.Agric.	Pass Marks	32
Year / Part	III / I	Time	3 hrs.

Subject: - Probability and Statistic (SH602)

- ✓ Candidates are required to give their answers in their own words as far as practicable.
- ✓ Attempt All questions.
- ✓ The figures in the margin indicate Full Marks.
- ✓ Necessary tables are attached herewith.
- ✓ Assume suitable data if necessary.

1. What is absolute and relative Measure of Dispersion? Construct a Box plot from the following data of marks of students as: [1+5]

Marks	10-20	20-30	30-40	40-50	50-60
No. of students	2	6	22	13	7

2. State the law of addition of probability. In a training, the 70% of persons achieved a rating of Satisfactory. Of those as rated as Satisfactory, 80% had Acceptable Scores on the personality test. Of those rated as Unsatisfactory, 35% had Acceptable Scores. Find the probability that an applicant would be a Satisfactory trainee given the Acceptable scores on personality test. [2+4]
3. Define Negative binomial distribution with its important characteristics. [5]
4. A particularly long traffic light on your morning commute is green 20% of the time that you approach it. Assume that each morning represents as independent trial. [5]
- i) Over five mornings, what is the probability that the light is green on exactly one day?
 ii) Over 20 mornings, what is the probability that the light is green on exactly four days? [5]
5. The distribution function for a random variable X is [5]

$$F(x) = 1 - e^{-2x} \text{ for } x \geq 0$$

$$= 0 \text{ for } x < 0$$

- i) Find $P(X > 2)$
 ii) Find mean and variance of the variable X.
6. Define Standard Normal Distribution with their respective probability density function and describe its properties. [5]
7. An article in Wear (Vol.152, 1992, pp.171-181) presents data on the fretting wear of mild steel and oil viscosity. Representative data follow, with x = oil viscosity and y = wear volume (10^{-4} cubic millimeters). [5]

y	240	181	193	155	172	110	113	75	94
x	1.6	9.4	15.5	20.0	22.0	35.5	43.0	40.5	33.0

- i) Fit the simple linear regression model using least
 ii) Predict fretting wear when viscosity $x = 30$
8. What are the two regression coefficients and what do they represent? Write the properties of regression coefficient. [5]
9. Define Central Limit Theorem. An electronics company manufactures resistors that have a mean resistance of 100 ohms and a standard deviation of 10 ohms. The distribution of resistance is normal. Find the probability that a random sample of 25 resistors will have an average resistance less than 95 ohms. [5]

10. Define standard error of sample mean. A population consist of the four numbers 12, 19, 13, 16. [5]
- Write down all possible sample size of two without replacement.
 - Find standard error of the sample mean.

11. Describe the procedure of the test of significance for difference of two population mean for large sample. [5]

12. In the investigation of a citizens' committee complaint about the availability of fire protection within the country, the distance in miles to the nearest fire station was measured for each of five randomly selected residences in each of four areas. [5]

Area 1	7	5	5	6	8
Area 2	1	4	3	4	5
Area 3	7	9	8	7	8
Area 4	4	6	3	7	5

Do these data provide sufficient evidence to indicate a difference in mean distance for the four areas at the $\alpha = 0.05$ level of significance?

OR

The diameter of steel rods manufactured on two different extrusion machines is being investigated. Two random samples of sizes $n_1 = 15$ and $n_2 = 17$ are selected, and the sample means and sample variances are $\bar{x}_1 = 8.73, s_1^2 = 0.35, \bar{x}_2 = 8.68,$ and $s_2^2 = 0.40,$ respectively. Assume that $\sigma_1^2 = \sigma_2^2$ and that the data are drawn from a normal distribution. Is there evidence to support the claim that the two machines produce rods with different mean diameters? Use $\alpha = 0.05$ in arriving at this conclusion.

13. A random sample of 500 adult residents of Maricopa County found that 385 were in favor of increasing the highway speed limit to 75 mph, while another sample of 400 adult residents of Pima County found that 267 were in favor of the increased speed limit. Construct 95% confidence interval on the difference in the two proportions. [5]
14. Define chi-square distribution. From the following data can you conclude that there is association between the purchase of brand and geographical region? [5]

	Region		
	Central	Eastern	Western
Purchase brand	40	55	45
Do not purchase brand	60	45	55

Use 5% level of significance.

15. The following table shows the number of hours 45 hospital patients slept following the administration of a certain anesthetic. [8]

7	10	12	4	8	7	3	8	5
12	11	3	8	1	1	13	10	4
4	5	5	8	7	7	3	2	3
8	13	1	7	17	3	4	5	5
3	1	17	10	4	7	7	11	8

- Find sample mean, sample variance and sample standard deviation.
- Compute a value that measures the amount of variability relative to the value of mean.

22 TRIBHUVAN UNIVERSITY
INSTITUTE OF ENGINEERING
Examination Control Division
2071 Chaitra

Exam.	Regular		
	Level	BE	Full Marks
Programme	BEL, BEX, BCT, B.Agric	Pass Marks	32
Year / Part	III / I	Time	3 hrs.

Subject: - Probability and Statistic (SH602)

- ✓ Candidates are required to give their answers in their own words as **far** as practicable.
- ✓ Attempt **All** questions.
- ✓ The figures in the margin indicate **Full Marks**.
- ✓ Necessary tables are attached herewith.
- ✓ Assume suitable data if necessary.

1. Two different sections of a statistics class take the same quiz and the scores are recorded below: [6]

- a) Find the range and standard deviation for each section
- b) What do the range values lead you to conclude about the variation in the two sections?
- c) Why is the range misleading in this case?
- d) What do the standard deviation values lead you to conclude about the variation in two sections?

Section 1	1	20	20	20	20	20	20	20	20	20	20	20
Section 2	2	3	4	5	6	14	15	16	17	18	19	

2. Define dependent and independent events with suitable examples. The independent probabilities that the three sections of a costing department will encounter a computer error are 0.2, 0.3 and 0.1 per week respectively. What is the probability that there would be: [6]

- i) At least one computer error per week
- ii) One and only one computer error per week

3. Write the differences and similarities between Binominal and Negative Binominal Distribution. [2+3]

4. A quality control engineer inspects a random sample of 4 batteries from each lot of 24 car batteries that is ready to shipment. If such a lot contain six batteries with slight defects. What are the probabilities that the inspector's sample will contain: [5]

- i) None of the batteries with defect?
- ii) At least two of the batteries with defects?
- iii) At most three of the batteries with defect?

5. A random variable X has the following probability density function as: [5]

$$f(x) = \begin{cases} kx^3(4-x)^2, & 0 < x < 1 \\ 0, & \text{otherwise} \end{cases}$$

Find the value of k, using this value of k find mean and variance of distribution.

6. The breakdown voltage X of a randomly chosen diode of a particular type is known to be normally distributed with mean 40 volts and variance 2.25 volts. What is the probability that the breakdown voltage will be: [5]

- i) Between 39 and 42 volts
- ii) Less than 44 volts
- iii) More than 43 volts

OR

The daily consumption of electric power in a certain city follow a gamma distribution with $\alpha = 2$ and $\beta = 3$. If the power plant of this city has daily capacity of 12 million kilowatt hours, what is the probability that this power supply will be inadequate on any given day?

7. State central limit theorem. An electrical firm manufactures light bulbs that have a length of life that is approximately normally distributed with mean equal to 800 hours and standard deviation of 4 hours. Find the probability that a random sample of 16 bulbs will have an average life of less than 12775 hours. [5]
8. What do you mean by sampling distribution of a sample mean and its standard Error? What would be the variance of sampling distribution of mean if sample is taken from finite population? [3+1]
9. Define partial and multiple correlation with suitable examples. Write down the properties of partial and multiple correlation. [5]
10. The following data gives the number of twists required to break a certain kind of forged alloy bar and percentage of alloying element A present in the metal. [5]

Number of twists	41	49	69	65	40	50	58	57	31	36
Percentage of element A	10	12	14	15	13	12	13	14	13	12

- i) Fit the regression equation of number of twists on percentage of element A. Determine the predicted number of twists required to break an alloy when percentage of element is 20.
- ii) Find 99% confidence interval for the regression coefficient (i.e. slope)
11. In a certain factory, there are two independent processes manufacturing the same item. The average weight in a sample of 250 items produced from one process is found to be 120 gram with a standard deviation of 12 gram, while the corresponding figures in a sample of 400 items from the other process are 124 and 14 respectively. Test whether the two mean weights differ significantly or not at 5 percent level of significance. [5]
12. Three trained operators work on production of new product. The productivity of the operators are recorded as below: [5]

Operators	Production			
1	10	12	14	16
2	12	11	13	16
3	14	15	12	11

Using ANOVA test whether the difference in average productivity due to the difference in operators are significant. Use $\alpha = 5\%$

OR

Define confidence level and significance level. A company claims that its light bulbs are superior to those of its main competitor. If a study showed that a sample of 40 of its bulbs has mean lifetime of 647 hours of continuous use with standard deviation of 27 hour. While a sample of 40 bulbs made by its main competitor had mean lifetime of 638 hours of continuous use with standard deviation of 31 hours. Does this substantiate claim at 1% level of significance?

13. Write down the steps for testing hypothesis on difference between two population proportions for the large sample size. [5]
14. 1072 students were classified according to their intelligence and economic conditions. Test whether there is any association between intelligence and economic condition. [6]

Economic Condition	Intelligence			
	Excellent	Good	Mediocre	Dull
Good	48	199	181	82
Not good	81	185	190	106

15. The sample of length of life of bulbs from two companies are given below:

[8]

Length of life (hours)	Company	
	A	B
500-600	10	3
600-700	21	8
700-800	6	15
800-900	8	12
900-1000	21	4
1000-1100	10	5
1100-1200	2	15
1200-1300	12	13
1300-1400	19	7
1400-1500	9	7
1500-1600	3	4
1600-1700	7	6
1700-1800	5	3
1800-1900	4	2
1900-2000	1	3

- i) Calculate mean length of life of bulbs for company A and company B.
- ii) Calculate sample standard deviation and sample variance for given data.
- iii) Which company's bulbs are more uniform?

Exam.	New Back (2066 & Later Batch)		
Level	BE	Full Marks	80
Programme	BEL, BEX, BCT, B.Agric.	Pass Marks	32
Year / Part	III / I	Time	3 hrs.

Subject: -Probability and Statistics (SH602)

- ✓ Candidates are required to give their answers in their own words as far as practicable.
- ✓ Attempt **All** questions.
- ✓ The figures in the margin indicate **Full Marks**.
- ✓ **Necessary tables are attached herewith.**
- ✓ Assume suitable data if necessary.

1. Write difference between measure of central tendency and measure of dispersion and their importance. The following table represents the marks of 100 students. [6]

Marks	0-20	20-40	40-60	60-80	80-100
No. of Students	14	?	27	?	15

If the mode value is 58, find the missing frequencies and the mean of all 100 students.

2. Define multiplication law of probability for dependent and independent events with suitable examples. The independent probabilities that the three sections of a costing department will encounter a computer error 0.2, 0.3 and 0.1 per week respectively. What is the probability that there would be: [6]
- i) At least one computer error per week?
 - ii) One and only one computer error per week?
3. Define Negative binomial distribution with an example. How does the negative binomial distribution differ from binomial distribution? [2+3]
4. A heavy machinery manufacturer has 3840 large generators in the field that are under warranty. If the probability is 1/1200 that any one will fail during the given year, find the probability: [5]
- i) That exactly 3 generators will fail during the given year?
 - ii) That between 2 and 6 are fail during the given year?
5. Define the standard normal distribution. Give the condition for normal approximation of Poisson distribution. [2+3]
6. The breakdown voltage X of a randomly chosen diode of a particular type is known to be normally distributed with mean 40 volts and variance 2.25 volts. What is the probability that the breakdown voltage will be: [5]
- i) Between 39 and 42 volts
 - ii) Between 40 and 43 volts
 - iii) Less than 44 volts

OR

A probability density function is given by $f(x) = Ax(6-x)^2$ for $0 < x < 6$

- i) Find the value of A
 - ii) Find the mean and variance of this distribution
7. Define sampling distribution of proportion with example. [4]
8. The monthly income of a particular group of retailer's follows a normal distribution with mean Rs.21,000.00 and standard deviation of Rs.9,487.00. A random sample of size 10 retailers was taken and the mean income is calculated. Find the probability that this sample lies between Rs.18,000.00 and Rs.27,000.00. [6]
9. Define partial correlation and multiple correlations with suitable examples. Write down properties of partial and multiple correlations. [5]
10. The following data gives the number of twists required to break a certain kind of forced alloy bar and percentage of alloying element A present in the metal. [5]

Number of twists	41	49	69	65	40	50	58	57	31	36
Percentage of element A	10	12	14	15	13	12	13	14	13	12

- i) Fit the regression equation of number of twists on percentage of element A. Determine the predicted number of twist required to break an alloy when percentage of element is 20.

11. The mean weight loss of $n = 16$ grinding balls after a certain length of time in mill slurry is 3.42 grams with a standard deviation of 0.68 gram. Construct a 99% confidence interval for the true mean weight loss of such grinding balls under the stated conditions. [4]

12. Four trained operators works on production of new product. The productivity of the operators are recorded as below: [6]

Operators	Production			
1	10	12	14	16
2	12	11	13	16
3	14	15	12	11
4	16	10	17	17

Using ANOVA, test whether the difference in average productivity due to the difference in operators are significant. Use $\alpha = 5\%$

OR

The following are the average weekly losses of worker hours due to accidents in 10 industrial plants before and after a certain safety program was put into operation:

Before	45	73	46	124	33	57	83	34	26	17
After	36	60	44	119	35	51	77	29	24	11

Use the 0.05 level of significance to test whether the safety program is effective.

13. Define confidence level and significance level. A manufacturer claimed that at least 95% of the cables supplied to the ABC Company confirmed to specifications. However, the production manager at ABC Company wasn't satisfied with the claim of the manufacturer. Hence, to test the claim, the manager examined a sample of 250 cables supplied last month and found that 228 cables as per the specifications. Can you conclude that the production manager is right to doubt on the claim of the manufacturer? ($\alpha=0.01$) [5]

14. Define chi-square distribution. A book containing 500 pages was thoroughly checked. The distribution of number of error page was given below as: [5]

Number of errors	0	1	2	3	4	5
Number of pages	275	138	75	7	4	1

Using chi-square test of goodness of fit, verify whether the arrivals follow a Poisson distribution at 5% level of significance.

15. The sample of length of life of bulbs from two companies are given below: [8]

Length of Life (hours)	Company	
	A	B
500-600	10	3
600-700	21	8
700-800	6	15
800-900	8	12
900-1000	21	4
1000-1100	10	5
1100-1200	2	15
1200-1300	12	13
1300-1400	19	7
1400-1500	9	7
1500-1600	3	4
1600-1700	7	6
1700-1800	5	3
1800-1900	4	2
1900-2000	1	3

- Calculate mean length of life of bulbs for Company A and Company B.
- Calculate sample standard deviation and sample variance for given data.
- Which Company's bulbs are more uniform?

22 TRIBHUVAN UNIVERSITY
INSTITUTE OF ENGINEERING
Examination Control Division
2070 Chaitra

Exam.	Regular		
Level	BE	Full Marks	80
Programme	BEL, BEX, BCT, B.Agr.	Pass Marks	32
Year / Part	III / I	Time	3 hrs.

Subject: - Probability and Statistics (SH602)

- ✓ Candidates are required to give their answers in their own words as far as practicable.
- ✓ Attempt All questions.
- ✓ The figures in the margin indicate Full Marks.
- ✓ Necessary tables are attached herewith.
- ✓ Assume suitable data if necessary.

1. Calculate the standard deviation from the following data regarding marks obtained by students in a test: [3+3]

Marks:	1	2	3	4	5	6	7	8	9
No. of Students	32	41	57	98	123	83	46	17	3

What will be the value of standard deviation if the marks obtained by each of the students are increased by one?

2. State Baye's theorem. A manufacturer of air-conditioning units purchases 70% of its thermostats from company A, 20% from company B and the rest from company C. Past experience shows that 0.5% of company A's thermostats, 1% of company B's thermostats and 1.5% of company C's thermostats are likely to be defective. An air-conditioning unit randomly selected from this manufacturer's production line was found to have a defective thermostat. Find the probability that company A supplied the defective thermostat. [2+4]
3. Write the differences and similarities between Binomial probability Distribution and Negative Binomial Probability distribution. [2+3]
4. The number of accident in a year attributes to taxi drivers in a city follows Poisson distribution with mean 3. Out of 1000 taxi driver, find the approximately the number of driver with: [5]
- i) No accidents in a year
 - ii) More than 3 accident in a year
5. Define normal distribution. Give the condition for normal approximation of Binomial distribution and Poisson distribution. [6]
6. The time required to assemble a piece of machinery is a random variable having approximately a normal distribution with mean 12.9 minutes and standard deviation of 2 minutes. What are the probabilities that the assembly of a piece of machinery of this kind will take (a) at least 11.5 minutes (b) between 11.0 to 14.8 minutes? [4]

OR

The probability density function given by

$$f(x) = cx^2, 0 < x < 3$$

0, Otherwise

- i) Find the value constant C?
 - ii) Compute $P(1 < x < 2)$
 - iii) Find the distribution function
7. What do mean by central limit theorem? Write its applications. [4]
8. The lifetime of a certain brand of an electric bulb may be considered a random variable with mean 1200 hours and standard deviation 150 hours. Using central limit theorem, find the probability that the sample mean of the lifetime with a sample of size 36, is between 1100 hours and 1300 hours. [2+4]

9. Define partial correlation and multiple correlations with suitable examples. Write two properties of each. [6]
10. Observation on the yield of a chemical reaction taken at various temperatures was recorded as follows: [4]

X (°C)	150	150	200	250	250	300	150
Y%	75.4	81.2	85.5	89	90.5	96.7	75.4

Fit a simple linear regression and estimate value of yield at 200°C.

11. An analysis for pH (acidity) in an random sample of water from 40 rainfalls showed that mean is 6.7 and s.d. is 0.5. Find a 99% confidence interval for the mean pH in rainfalls. [4]
12. As a part of investigation of the collapse of the roof of a building, a testing laboratory is given all the available bolts that connected the steel structure at three different positions on the roof. The forces required to shear each of these bolts (coded values) are as follows: [6]

Position 1	90, 82, 79, 98, 83, 91
Position 2	105, 89, 93, 104, 89, 95, 86
Position 3	83, 89, 80, 94

Perform an ANOVA to test at the 0.05 level of significance whether the difference among the sample means at the three positions are significant.

OR

The following are the average weekly losses of worker-hours due to accidents in 10 industrial plants before and after a certain safety program was put into operation:

45 and 36, 73 and 60, 46 and 44, 124 and 119, 33 and 35, 57 and 51, 83 and 77, 34 and 29, 26 and 24, 17 and 11. Use the 0.05 level of significance to test whether the safety program is effective.

13. The results of polls conducted two weeks and four weeks before an election are shown in the following table: [5]

	Two weeks before election	Four weeks before election
For republican candidate	79	91
For democratic candidate	84	66
Undecided	37	43

Use the 0.05 level of significance to test whether there has been change in opinion during the 2 weeks between the polls.

14. A manufacturer of submersible pumps claims that at most 30% of the pumps require within the first 5 years of operation. If a random sample of 120 of these pumps includes 47 which required repairs within the first 5 years, test the null hypothesis $p = 0.30$ against the alternative hypothesis $P > 0.30$ at the 0.05 level of significance. [5]
15. The following data are the ages (in months) at which $n = 50$ children were first enrolled in a preschool. [8]

38	40	30	35	39
47	35	34	43	41
32	34	41	30	46
55	39	33	32	32
42	50	37	39	33
40	48	36	31	36
36	41	43	48	40
35	40	30	46	37
45	42	41	36	50
45	38	46	36	31

- a) Find sample mean, sample variance and sample standard deviation
 b) Compute a value that measures the amount of variability relative to the value of mean

Exam.	New Batch (2066 & Later Batch)		
Level	BE	Full Marks	80
Programme	BEL, BEX, BCT, B.Agric.	Pass Marks	32
Year / Part	III / I	Time	3 hrs.

Subject: - Probability and Statistics (SH602)

- ✓ Candidates are required to give their answers in their own words as far as practicable.
- ✓ Attempt All questions.
- ✓ The figures in the margin indicate Full Marks.
- ✓ Necessary tables are attached herewith.
- ✓ Assume suitable data if necessary.

1. In statistics paper five candidates obtain the marks as 33, 38, 48, 59 and 72. Calculate the mean and standard deviation of these marks. If 10 marks are added for each student, what will be mean and standard deviation? [3+3]
2. Distinguish between mutually exclusive and equally likely events with examples. What is the use of Bayes theorem in theory of probability? In a college 45% students belong to Civil, 30% Electronics and remaining to other faculties. The probability of being top is 5%, 4% and 2% respectively in civil, electronics and others. If this year's result is published, what is the probability that the topper is from electronics? [6]
3. Define poisson probability Distribution. Write the conditions for poisson approximation to Binomial Distribution. [2+3]
4. A quality control engineers inspects a random sample of 3 batteries from each lot of 24 car batteries that is ready to shipment. If such a lot contain six batteries with slight defects, what is the probabilities that the inspector's sample will contain. [5]
 - i) None of the batteries with defect?
 - ii) Only one of the batteries with defect?
 - iii) At least two of the batteries with defect?
5. Define standard normal distribution with area property. [6]
6. The marks obtained by IOE students in statistics are 50 on average with variance 16. If 5000 students have given the exam, find the following: [4]
 - a) The number of students securing marks less than 40?
 - b) The number of students securing marks between 35 to 60?

OR

Let X denotes the amount of time for which a book on two-hour reserve at a college library is checked out by a randomly selected students, and suppose that X has density function $f(x) = kx, 0 \leq x \leq 2$
 0, otherwise

- a) Find the value of k
- b) Calculate $P(X \leq 1)$
- c) Calculate $P(0.5 \leq X \leq 1.5)$
- d) Calculate $P(1.5 < X)$
7. Define sampling distribution of mean. [4]
8. Define Central Limit Theorem. In a sample of 16 observations from a normal distribution with mean of 150 and a variance of 256, what is (a) $P(\bar{x} < 160)$ (b) $P(\bar{x} > 142)$ [2+4]
9. What is the difference between correlation and regression? Plot the sample regression line of Y on X. [2+4]

Speed x	30	40	50	60	70
Stopping distance y	160	240	330	435	500

10. What do you mean by correlation coefficient? Show that correlation coefficient lies between -1 and +1. [4]

1. Describe the procedure of the test of significance of difference between two means for large sample. [4]

2. Set up an ANOVA table for the following acre production of data for three varieties of wheat each grown on 4 plots and state if the variety differences are significant. Use $\alpha = 0.05$. [6]

Plot of land	Variety of wheat		
1	6	5	5
2	7	5	4
3	3	3	3
4	8	7	4

OR

The following random samples are measurement of the heat producing capacity (in millions of calories per ton) of specimens of coal from two mines:

Mine 1	8260	8130	8350	8070	8340	-
Mine 2	7950	7890	7900	8140	7920	7840

Use the 0.01 level of significance to test whether the difference between means of these two samples is significant.

What do you mean by chi square distribution? The following test gives the information for the engineering students interest with ability in computer. Is there any significant relationship between interest in engineering and ability in computer? [5]

Ability in computer	Interest in Engineering	Low	Average	High
	Low		6	12
Average		33	61	18

Two different types of injection-molding machines are used to form plastic parts. A part is considered defective if it has excessive shrinkage or is discolored. Two random samples, each of size 300, are selected and 15 defective parts are found in the sample from machine 1 while 8 defective parts are found in the sample from machine 2. Is it reasonable to conclude that both machines produce the same fraction of defective parts, using $\alpha = 0.05$? [5]

The following table shows the number of hours 45 hospital patients slept following the administration of a certain anesthetic. [8]

7	10	12	4	8	7	3	8	5
12	11	3	8	1	1	13	10	4
4	5	5	8	7	7	3	2	3
8	13	1	7	17	3	4	5	5
3	1	17	10	4	7	7	11	8

Find sample mean, sample variance and sample standard deviation
Compute a value that measures the amount of variability relative to the value of mean

Exam.	Regular		
Level	BE	Full Marks	80
Programme	BEL, BEX, BCT, B.Agric.	Pass Marks	32
Year / Part	III / I	Time	3 hrs.

Subject: - Probability and Statistics (SH602)

- ✓ Candidates are required to give their answers in their own words as far as practicable.
- ✓ Attempt **All** questions.
- ✓ The figures in the margin indicate **Full Marks**.
- ✓ Necessary tables are attached herewith.
- ✓ Assume suitable data if necessary.

1. The following are data on the breaking strength (in pounds) of 3 kinds of material: [2×3]

Material 1	144	181	200	187	169	171
Material 2	186	194	176	182	133	183
Material 3	197	165	180	198	175	164

- i) Calculate the average breaking strength and the median breaking strength for each material.
 - ii) Calculate standard deviation and variance for each material.
2. Define independent and mutually exclusive events with an example. An assembly plant receives its voltage regulators from these three different suppliers, 60% from supplier A, 30% from supplier B and 10% from supplier C. It is also known that 95% of voltage regulators from A, 80% of these from B and 65% these from C perform according to specifications. What is the probability that: [2×3]
- i) Anyone voltage regulator received by the plant will perform according to specifications.
 - ii) A voltage regulator that perform according to specification came from B and C.
3. Write difference between binominal distribution and negative binomial distribution with suitable examples. [2+2]
4. Among the 12 solar collectors on display at a trade show, 9 are flat-plate collectors and the others are concentrating collectors. If a person visiting the show randomly selects 6 of the solar collectors to check out, what is the probability that [2+2+2]
- i) Non of them will be flat-plate collectors.
 - ii) At least 3 of them will be flat-plate collectors.
 - iii) At most 2 of them will be concentrating collectors.
5. Define standard normal distribution. Write down its importance in engineering field. [4]
6. The breakdown voltage X of randomly chosen diode of a particular type is known to be normally distributed with mean 40 and standard deviation 1.5 volts. What is the probability that the breakdown voltage will be [6]
- i) Between 39 and 42 volts
 - ii) At most 43 volts
 - iii) At least 3.9 volts

OR

If a random variable X has a function

$$f(x) = 2e^{-2x} \quad \text{for } x > 0$$

$$0 \quad \text{for } x \leq 0$$

- Find (i) Verify that the function is probability density function
 (ii) $P(1 < x < 3)$
 (iii) Find mean and variance

TRIBHUVAN UNIVERSITY
INSTITUTE OF ENGINEERING
Examination Control Division
2079 Bhadra

Exam.	Regular		
Level	BE	Full Marks	80
Programme	BEX, BCT	Pass Marks	32
Year / Part	III / I	Time	3 hrs.

Subject: - Computer Graphics (EX 603)

- ✓ Candidates are required to give their answers in their own words as far as practicable.
- ✓ Attempt All questions.
- ✓ The figures in the margin indicate Full Marks.
- ✓ Assume suitable data if necessary.

1. Consider a raster system with a resolution of 1920×1080 . How much storage is required if 24 bits per pixel are to be stored in a device with refresh rate of 50 Hz? Find out the aspect ratio. [4]
2. How do you apply symmetry concept while drawing circle? Calculate the point in the circumferences of the circle having radius 8 unit and center at (+8, 10) using midpoint circle algorithm. [2+6]
3. What do you mean by homogenous coordinates? By listing the steps involved, find out the final composite matrix for performing a rotation by 45 degrees about an arbitrary point (5, 5) in anti-clockwise direction. Use the obtained composite matrix to obtain the transformed coordinates of a triangle A(5, 6), B(6, 2) and C(4, 1). [1+5+2]
4. Explain about 3D viewing pipeline. How world-to-viewing coordinate transformation is performed? Describe with expression. [5+5]
5. Write the properties of Bezier curve. A cubic Bezier curve is described by the four control points. (0, 0), (3, 1), (5, 2) and (8, 1). Find the Bezier polynomial and the coordinate at $f = 0.25, 0.5, 0.75$. [3+8]
6. What is polygon table? List the rules for making error free polygon table. How do you calculate the spatial orientation of a polygon? [3+2+4]
7. Compare object space method and image space method. Explain depth buffer method in detail. Compare it with A-buffer method. [2+5+3]
8. Find out the total intensity at the centroid of a triangle defined by A(2, 1, 1), B(0, 1, 1), C(0, 0, 1), when illuminated by a point light source of intensity $I_L = 0.6$ at (3, 2, 8) using Phong Illumination model. The viewer is at (4, 3, 8). Assume ambient intensity $I_a = 0.1$ and parameters: $k_a = 0.5, k_d = 0.8, k_s = 0.7$, take $x = 5$. [centroid: $(x_1 + x_2 + x_3)/3, (y_1 + y_2 + y_3)/3, (z_1 + z_2 + z_3)/3$]. Explain briefly different ways of shading this triangle. [8+6]
9. Why OpenGL is used? Write the basic command to draw the pixel rectangle and polygon in OpenGL. [2+4]

TRIBHUVAN UNIVERSITY
INSTITUTE OF ENGINEERING
Examination Control Division
2079 Baishakh

Exam.	Back		
Level	BE	Full Marks	80
Programme	BEX, BCT	Pass Marks	32
Year / Part	III / I	Time	3 hrs.

Subject: - Computer Graphics (EX 603)

- ✓ Candidates are required to give their answers in their own words as far as practicable.
- ✓ Attempt All questions.
- ✓ The figures in the margin indicate Full Marks.
- ✓ Assume suitable data if necessary.

1. What are the differences between random and raster display technologies? When do we prefer them? [6]
2. Write an algorithm for Brescnham's method of line drawing. Digitize a line with end points (10, 20) and (15, 2) using this algorithm. [5+5]
3. Find the composite transformation matrix for reflection about a line $y = mx + c$. [8]
4. Describe polygon, Vertex and Edge table. How these terms can be used to construct a model of Dharahara. [2+2+2+2]
5. What do you understand by affine transformation? Derive expressions for oblique projectiman paralle projection. [2+4+4]
6. What is a Bezier Curve? Find the coordinates of Benzier curve at $u = 0.25, 0.5$ and 0.75 with respect to the control points (10, 15), (15,20), (20, 35), (25, 10) using Bezier function. [1+5]
7. How back-face detectium method is used to detect visible surfaces? What are it's limitation? Purpose an approach to overcome it's limitations. [4+2+4]
8. Derive an expression for phong illumination model for light sources. [8]
9. Find out the total intensity at the centroid of a triangle defind by A(2,1,1), B(0,1,1), C(0,0,1), when illuminated by a point light source of intensity $I_L = 0.6$ at (2,2,6) using illumination model. The viewer is at (2,3,6). Assume ambient Intensity $I_a = 0.1$ and parameters: $k_a = 0.5, k_d = 0.8, k_s = 0.7$, take $n = 10$. [8]
[centroid: $(x_1 + x_2 + x_3)/3, (y_1 + y_2 + y_3)/3, (z_1 + z_2 + z_3)/3$]
10. What is open GL? How can we use lighting in open GL? [2+4]

TRIBHUVAN UNIVERSITY
 INSTITUTE OF ENGINEERING
Examination Control Division
 2078 Kartik

Exam.	Back		
Level	BE	Full Marks	80
Programme	BEX, BCT	Pass Marks	32
Year / Part	III / I	Time	3 hrs.

Subject: - Computer Graphics (EX 603)

- ✓ Candidates are required to give their answers in their own words as far as practicable.
- ✓ Attempt All questions.
- ✓ The figures in the margin indicate Full Marks.
- ✓ Assume suitable data if necessary.

1. What is computer graphics? Calculate the total memory required to store a 10 minute video in a SVGA system with 24 bit true color and 60 fps refresh rate. [2+4]
2. Write an algorithm for drawing a circle. Using midpoint circle drawing algorithm, calculate the coordinates on the first quadrant of a circle having radius 8 and centre (10, 10). [4+6]
3. It is necessary to construct curves using parameteric equations? Justify. List down the steps for modeling curves using splines. [4+4]
4. Reflected the triangle ABC about the line $3X - 4Y + 8 = 0$. The position vector of the coordinate ABC is given A(4, 1), B(5, 2) and C(4, 3). [8]
5. Describe 3D viewing pipeline. Derive complete world-to-viewing coordinate transformation matrix. [3+7]
6. Why do we use geometric tables and attribute tables for defining a polygon surface? How do you calculate the spatial orientation of a polygon? [3+3]
7. What is the limitation of Z-buffer method? How does A-buffer method overcome it, explain? [3+7]
8. Derive the expression to calculate the total light intensity in a point. [8]
9. Compare and contrast between Gouraud and Phong shading model. [8]
10. What is OpenGL? How can we draw colored line and polygon using OpenGL? [2+4]

TRIBHUVAN UNIVERSITY
INSTITUTE OF ENGINEERING
Examination Control Division
2078 Bhadra

Exam.	Regular		
Level	BE	Full Marks	80
Programme	BEX, BCT	Pass Marks	32
Year / Part	III / I	Time	3 hrs.

Subject: - Computer Graphics (EX 603)

- ✓ Candidates are required to give their answers in their own words as far as practicable.
- ✓ Attempt All questions.
- ✓ The figures in the margin indicate Full Marks.
- ✓ Assume suitable data if necessary.

1. Distinguish between Raster and Vector graphics with suitable example. [6]
2. Digitize the endpoint (20, 10) and (30, 18) using Bresenham's algorithm. How the demerits of DDA is addressed in Bresenham's algorithm. [7+3]
3. Derive the composite matrix for rotation about arbitrary point (a, b) in clockwise direction with angle (θ). Write an algorithm for Cohen Sutherland line clipping algorithm. [6+4]
4. What are 3D Rotation and Shearing? Explain with matrix representations. A unit length cube with diagonal passing through (0, 0, 0) and (1, 1, 1) is sheared with respect to yz plane with shear constants = 2 in both directions. Obtain the coordinates of all the corners of the cube after shearing. [3+7]
5. What is Parametric Cubic Curve and why do you need it? Write down the step for cubic spline interpolation. [3+5]
6. What is Wire-frame model and why do we need polygon data table? Explain with examples? [5]
7. Describe Z-Buffer method of visible surface detection. Compare this method to other methods of visible surface detection. [6+2]
8. What do understand by diffused and specular reflections and explain in detail how these terms are included in illumination model? [5+5]
9. Define the term illumination and rendering. Write down the steps for phong shading method. [2+6]
10. Write down the Open GL syntax to draw basic 2D geometric primitives with examples. [5]

Exam.	Regular		
Level	BE	Full Marks	80
Programme	BEX, BCT	Pass Marks	32
Year / Part	III / I	Time	3 hrs.

Subject: - Computer Graphics (EX 603)

- ✓ Candidates are required to give their answers in their own words as far as practicable.
- ✓ Attempt All questions.
- ✓ The figures in the margin indicate Full Marks.
- ✓ Assume suitable data if necessary.

1. Compare Raster-scan Display with Random-scan Display. [6]
2. Write the advantages of Bresenham's line drawing algorithm. Digitize the Ellipse with radius $R_x = 12$ and $R_y = 7$ and center $(19, 10)$. [2+8]
3. Define window and view port. Describe about two-dimensional viewing pipeline with matrix representation at each steps. [2+8]
4. Derive an expression for Perspective projection of a 3D point. Also, obtain perspective projection co-ordinates for the pyramid with vertices of base $(15, 15, 10)$, $(20, 20, 10)$, $(25, 15, 10)$, $(20, 10, 10)$ and apex $(20, 15, 20)$ given that $z_{prp} = 20$ and $z_{vp} = 0$. [5+5]
5. Differentiate between Interpolation and approximation. Explain the process of performing curve modeling using splines. [3+5]
6. How can we model cone or cylindrical like surfaces using boundary representation and technique? [6]
7. Explain Back-face detection algorithm for visible surface detection. Find the visibility for the surface BED and ABCD where observer is at $P(5, 5, 5)$. [3+5]

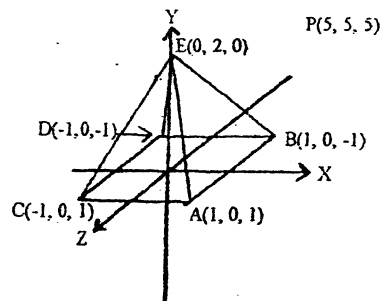

8. Define the term Surface rendering with Illumination model. Derive an expression to calculate the intensity of Diffuse reflection with necessary equations and figures. How do you consider the distance to calculate the intensity for Specular and Diffuse Reflection? [2+5+3]
9. What is Phong shading method? Can we use this method to reduce Mach-Band effect? [6+2]
10. What do you mean call back function? Illustrate with example. [4]

Exam.	Back		
Level	BE	Full Marks	80
Programme	BEX, BCT	Pass Marks	32
Year / Part	III / I	Time	3 hrs.

Subject: - Computer Graphics (EX 603)

- ✓ Candidates are required to give their answers in their own words as far as practicable.
- ✓ Attempt **All** questions.
- ✓ The figures in the margin indicate **Full Marks**.
- ✓ Assume suitable data if necessary.

1. Differentiate between raster and vector graphics. Calculate the frame buffer size (in KB) for a raster system recording a video for 1 min with resolution of 1280×1024, and storing 24 bits per pixel with a refresh rate of 25 fps. [2+4]

2. Explain the process of drawing ellipse in a raster graphics. Determine the pixel positions of following curve in first quadrant using mid-point algorithm. [4+6]

$$\frac{x^2}{64} + \frac{y^2}{36} = 1$$

3. What do you mean by homogeneous coordinates? Rotate a triangle A(5,6), B(6,2) and C(4,1) by 45 degree about an arbitrary pivot point (3,3). [2+6]

4. List down the steps for rotating a 3D object by 90° in counter clockwise direction about an axis joining end points (1,2,3) and (10,20,30). Also derive the final transformation matrix. [10]

5. Mention two important properties of Bezier Curve and find the Bezier Curve which passes through (0,0,0) and (-2,1,1) and is controlled by (7,5,2) and (2,0,1). [2+6]

6. Represent the following surfaces by polygon table method and find the normal of surface S1. [2+5]

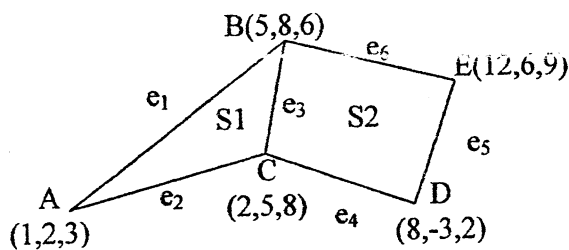

7. How hidden surfaces can be removed? Explain in detail about depth buffer methods. [8]

8. What is OpenGL? How pixels, lines and polygon is drawn and transformation is performed in OpenGL? [2+5]

9. List down different types of object and explain how Phong illumination model is used to calculate intensity in for these objects along with mathematical expression. [8]

10. Explain in detail about Phong shading. [8]

TRIBHUVAN UNIVERSITY
INSTITUTE OF ENGINEERING
Examination Control Division
2075 Chaitra

Exam.	Regular / Back		
Level	BE	Full Marks	80
Programme	BEX, BCT	Pass Marks	32
Year / Part	III / I	Time	3 hrs.

Subject: - Computer Graphics (EX 603)

- ✓ Candidates are required to give their answers in their own words as far as practicable.
- ✓ Attempt All questions.
- ✓ The figures in the margin indicate Full Marks.
- ✓ Assume suitable data if necessary.

1. Define computer graphics. Illustrate about components for computer graphics. [2+4]
2. Differentiate between DDA and Bresenhamline drawing algorithm. Explain Bresenham line drawing algorithm and use this algorithm to draw a line with end points (25,20) and (15,10). [2+8]
3. Write matrix for 2D reflection about axes. Derive the transformation matrix responsible for the reflection of 2D object about line $y+x=0$. [2+6]
4. Explain with a block diagram about the 3D viewing pipeline. Along with the transformation matrix, describe how perspective projection is performed? [4+4]
5. Find the coordinates at $U=0.25, 0.5, \text{ and } 0.75$ with respect to the control points (10,10), (15,25), (20,30), and (25,5) using Bezier function. Draw your curve with given control points. [8]
6. How can a 3D-Dimensional object be modelled? How a normal to a plane of this object is calculated? [3+3]
7. Explain backface detection algorithm. Determine whether two surfaces of a object with normals $2\vec{i} - 3\vec{j} + 4\vec{k}$ and $\vec{i} + \vec{j} - 2\vec{k}$ respectively, viewed from a direction given by $\vec{i} - \vec{j} + \vec{k}$ are backface or frontface. [5+5]
8. How polygon is drawn in OpenGL? How lighting is applied to this polygon surface? [2+3]
9. Derive the expression to calculate the intensity of Specular Reflection in the presence of Point light source. Also write the expression for multiple light sources. How do you consider the distance to calculate the intensity for Specular Reflection? [8+4]
10. Write down an algorithm for intensity interpolation shading scheme. [7]

841

24
TRIBHUVAN UNIVERSITY
INSTITUTE OF ENGINEERING
Examination Control Division
2075 Ashwin

Exam.	Back		
Level	BE	Full Marks	80
Programme	BEX, BCT	Pass Marks	32
Year / Part	III / I	Time	3 hrs.

Subject: - Computer Graphics (EX603)

- ✓ Candidates are required to give their answers in their own words as far as practicable.
- ✓ Attempt All questions.
- ✓ The figures in the margin indicate Full Marks.
- ✓ Assume suitable data if necessary.

1. Compare random and raster display technology. [6]
2. How symmetry property of circle reduces complexity to draw a complete circle. Derive decision parameter for midpoint circle algorithm assuming the start position as $(-r, 0)$ points are to be generated along the curve path in counter clockwise direction. [3+7]
3. Use Liang Barsky line clipping algorithm to clip a line starting from $(6, 100)$ and ending at $(60, 5)$ against the window having its lower left corner at $(10, 10)$ and upper right corner at $(90, 90)$. [8]
4. Reflect the triangle ABC about the line $3X-4Y+8=0$ the position Vector of coordinate ABC as $A(4, 1)$, $B(5, 2)$ and $C(4, 3)$. [8]
5. Develop the Matrix to transform an object from Three-Dimensional World Coordinate to Viewing Coordinate system. A unit length cube with diagonal passing through $(0, 0, 0)$ and $(2, 2, 2)$ is shared with respect to ZX-plane with share Constants = 3 in both directions. Obtain the final coordinates of the cube after shearing. [5+7]
6. Do you agree Polygon Descriptions are referred to as "Standard Graphics Object", If yes, Why? If you have three coordinates $(X1, Y1, Z1)$, $(X2, Y2, Z2)$ and $(X3, Y3, Z3)$, then how do you find the coefficient of Surface Normal $N(A, B, C)$? [3+3]
7. Compare the Gouraud shading with Phong shading. Develop the expression for Phong model considering the intensity attenuation for multiple point light sources with necessary figures. [6+8]
8. What is the difference between object space method and image space method for visible surface determination? Describe scan line method to find visible lines with example. [4+8]
9. What is OpenGL? Explain Call back function? [2+2]

Exam.	Back		
Level	BE	Full Marks	80
Programme	BEX, BCT	Pass Marks	32
Year / Part	III / I	Time	3 hrs.

Subject: - Computer Graphics (EX603)

- ✓ Candidates are required to give their answers in their own words as far as practicable.
- ✓ Attempt All questions.
- ✓ The figures in the margin indicate Full Marks.
- ✓ Assume suitable data if necessary.

1. Distinguish between Raster and Vector graphics methods. When do we prefer them? [6]
2. Digitize the line with end points A(20,10) and B(30,18) using Bresenham algorithm. [10]
3. Clip the line P1P2 with P1(-5,3) and P2(15,9) with clip window having diagonal coordinate (0,0) and (10,10) using Liang-Barskey line clipping method. [8]
4. Explain the steps required to rotate an object in 3D about a line which is not parallel to any one coordinate axis. [10]
5. How Geometric tables are used to represent a 3D object? Explain with example. Give conditions to generate error free table. [8]
6. Explain properties of Bezier curve. Find the coordinate at $u = 0.2$ with respect to the control points (1,1), (4,6) (8,-3) and (12,2) using Bezier function. [8]
7. Differentiate image space and object space method for visible surface determination. Explain scanline method to determine visible surface of object. [8+4]
- 8.

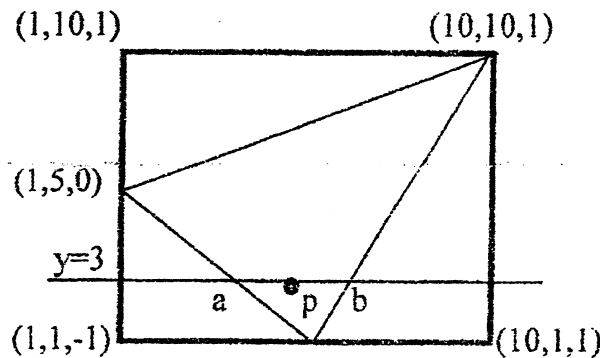

Find out intensity of light reflected from the midpoint P on scan line $y = 3$ in the above given figure using Gouraud shading model. Consider a single point light source located at positive infinity on Z-axis and assume vector to the eye as (1,1,1). Given $d = 0$, $K = 1$, $I_a = 1$, $I_L = 10$, $K_s = 2$, $K_a = K_d = 0.8$ for use in a simple illumination model. [12]

9. What is OpenGL? Explain Callback Function. [4+2]

Exam.	Regular		
Level	BE	Full Marks	80
Programme	BEX, BCT	Pass Marks	32
Year / Part	III / I	Time	3 hrs.

Subject: - Computer Graphics (EX603)

- ✓ Candidates are required to give their answers in their own words as far as practicable.
- ✓ Attempt All questions.
- ✓ The figures in the margin indicate Full Marks.
- ✓ Assume suitable data if necessary.

1. Calculate the size of frame buffer required to store a 640×480 B and W video of length 5 minutes without compression. [4]
2. Discuss the Digital Differential Analyzer (DDA) line drawing algorithm in detail. Also give its advantages and disadvantages. [8+4]
3. A triangle A (15, 20), B (20, 30) and C (30, 20) lies inside a window (10, 10), (40, 50). Find the final image of this triangle after transforming into the viewport (0, 0), (20, 20). Show all transformation steps. [8]
4. Briefly explain various projections? Find the new coordinates of a unit cube 90° rotated about an axis defined by its endpoints A (2,1,0) and B (3,3,1). [3+7]
5. Explain vertex, edge and surface table using a suitable example. What are the guidelines to generate error free table? [5+5]
6. Explain about parametric Cubic curve? What is Bezier curve? Explain its properties. [2+3+4]
7. Discuss back face removal algorithm? Describe its limitation. [8+2]
8. Compare Gouraud shading and phong's shading in detail. [9]
9. Why Open GL required? Explain call back function. [8]

Exam.	New Back (2066 & Later Batch)		
Level	BE	Full Marks	80
Programme	BEX, BCT	Pass Marks	32
Year / Part	III / I	Time	3 hrs.

Subject: - Computer Graphics (EX603)

- ✓ Candidates are required to give their answers in their own words as far as practicable.
- ✓ Attempt All questions.
- ✓ The figures in the margin indicate Full Marks.
- ✓ Assume suitable data if necessary.

1. Differentiate between vector and raster scan systems. [4]
2. Derive and write midpoint algorithm for drawing a circle. [5+5]
3. What are the different steps of two dimensional world to screen viewing transformation? Describe with matrix representation at each steps. [5]
4. Obtain the end points of the line that connects P1(0,120) and P2(130,5) after cohen-sutheland clipping. The clip window has the following parameters. [5]

$x\omega_{\min} = 0, y\omega_{\min} = 0, x\omega_{\max} = 150$ and $y\omega_{\max} = 100$
5. Describe three dimensional viewing pipelining. Derive the transformation matrix for parallel projection. [4+6]
6. Explain about parametric cubic curve? What is a Bezier Curve? Explain its properties with examples. [2+6]
7. Explain boundary representation technique to represent three dimensional objects with suitable example. [8]
8. Compare object space method with image space method. Explain, How Back-face detection method is used to detect visible surface. Also explain z-Buffer method. [2+4+4]
9. Define and explain the term ambient light, diffuse reflection and specular reflection with appropriate mathematical expressions. [7]
10. Explain the method of Phong shading for polygon rendering. [7]
11. Explain about Open GL and call back functions. [6]

Exam.	Regular		
Level	BE	Full Marks	80
Programme	BEX, BCT	Pass Marks	32
Year / Part	III / I	Time	3 hrs.

Subject: - Computer Graphics (EX603)

- ✓ Candidates are required to give their answers in their own words as far as practicable.
- ✓ Attempt All questions.
- ✓ The figures in the margin indicate Full Marks.
- ✓ Assume suitable data if necessary.

1. What are the differences between random and raster display technologies? [4]
2. How do you apply symmetry concept while drawing circle? Calculate the point in the circumferences of the circle having radius 8 unit and center at (-5, 10) using midpoint circle algorithm. [2+8]
3. What are the conditions for a point clipping? Find the clipped region of the line with endpoints (5, 130) and (50, 5) in a rectangular window with (10, 10) and (100, 100) diagonal vertices using Cohen-Sutherland line clipping algorithm. [10]
4. What is 3D Shearing? Write its matrix representation. A unit length cube with diagonal passing through (0,0,0) and (1,1,1) is sheared with respect to yz place with the shear constants = 2 in both directions. Obtain the coordinates of all the corners of the cube after shearing. [2+8]
5. Explain about parametric cubic curves. What do you mean by Bezier Curve? Explain the properties of Bezier curves. [2+2+4]
6. Explain how the geometric and attribute information of a three dimensional objects are stored for the object representation? What are the conditions for error free generation of polygon table? [4+4]
7. Outline the Z buffer algorithm. List the advantages and disadvantages of the z-buffer algorithm. [6+2+2]
8. Explain about different types of lighting sources and how these light sources affect the illumination model? Explain about the intensity interpolation surface rendering technique by highlighting its pro and cons. Also give example about phong illuminations model. [3+5+6]
9. Why GLUT is implemented in OpenGL? What are the applications of OpenGL? [2+4]

Exam.	New Back (2066 & Later Batch)		
Level	BE	Full Marks	80
Programme	BEX, BCT	Pass Marks	32
Year / Part	III / I	Time	3 hrs.

Subject: - Computer Graphics (EX603)

- ✓ Candidates are required to give their answers in their own words as far as practicable.
- ✓ Attempt **All** questions.
- ✓ The figures in the margin indicate **Full Marks**.
- ✓ Assume suitable data if necessary.

1. Derive the Bresenham's decision parameter to draw a line moving from left to right and having negative slope. State the condition to identify you are in the second region of the ellipse using mid point algorithm. [8+2]
2. Write down the condition for point clipping. Find the clipped region in window of diagonal vertex (10,10) and (100,100) for line P_1 (5,120) and P_2 (80,7) using Liang-Barsky line clipping method. [2+8]
3. Find the transformation matrix the transforms that rectangle ABCD whose center is at (4,2) is reduced to half of its size, the center will remain same. The co-ordinate of ABCD are A(0,0), B(0,4), C(8,4) and D(8,0). Find Coordinate of new square. Also derive the transformation matrix to convert this rectangle to square. [10]
4. List out the properties of Bezier curve. What is order of continuity? Explain. [8]
5. Explain the significance of spatial orientation of a surface and polygon tables. Explain with example. [8]
6. Compare Z-buffer and A-Buffer algorithm. Also write algorithm to find visible surfaces using scan-line method. [10]
7. Explain the general illumination model. How this model is used for rendering by using gouroud shading. [7+7]
8. Write short notes on: [5+5]
 - a) Raster scan display
 - b) OpenGL

c1 / 02

34

TRIBHUVAN UNIVERSITY
INSTITUTE OF ENGINEERING
Examination Control Division
2071 Chaitra

Exam.	Regular		
Level	BE	Full Marks	80
Programme	BEX, BCT	Pass Marks	32
Year / Part	III / I	Time	3 hrs.

Subject - Computer Graphics (EX603)

- ✓ Candidates are required to give their answers in their own words as far as practicable.
- ✓ Attempt All questions.
- ✓ The figures in the margin indicate Full Marks.
- ✓ Assume suitable data if necessary.

1. Differentiate Random and Raster display technology. [4]
2. Compare between DDA and Bresenham's line drawing algorithm. Derive and write mid-point algorithm to draw ellipse. [10]
3. The reflection along the line $y = x$ is equivalent to the reflection along the X-axis followed by counter clock wise rotation by α (alpha) Degree. Find the angle α . [10]
4. Write rotation matrix in clockwise direction with respect to x-axis, y-axis and z-axis. Rotate the object $(0, 0, 0)$, $(2, 3, 0)$, $(5, 0, 4)$ about the rotation axis $y = 4$. [3+7]
5. Write down properties of Bezier curve. Find equation of Bezier curve whose control points are $P_0(2,6)$, $P_1(6,8)$ and $P_2(9,12)$. Also find co-ordinate of point at $u = 0.8$. [10]
6. Explain boundary representation technique to represent the 3D object with suitable example. How can you find the spatial orientation of a surface? [8+2]
7. Explain z-buffer algorithm along with necessary steps needed to calculate the depth. What is its drawback? [10]
8. Define the terms:
 - i) Ambient light
 - ii) Lambert cosine law
 - iii) Diffuse reflection
 - iv) Specular reflectionAlso find equation for intensity of point by using Phong illumination model. [4+2]
9. What is OpenGL? Explain callback function. [10]

Exam.	New Back (2066 & Later Batch)		
Level	BE	Full Marks	80
Programme	BEX, BCT	Pass Marks	32
Year / Part	III / I	Time	3 hrs.

Subject: - Computer Graphics (EX603)

- ✓ Candidates are required to give their answers in their own words as far as practicable.
- ✓ Attempt All questions.
- ✓ The figures in the margin indicate Full Marks.
- ✓ Assume suitable data if necessary.

1. Consider a raster scan system having 12 inch by 10 inch screen with a resolution of 100 pixels per inch in each direction. If the display controller of this system refreshes the screen at the rate of 50 frames per second, how many pixels could be accessed per second and what is the access time per pixel of the system? [4]
2. What is scan conversion? Derive the Bresenham's decision parameter to draw a line with negative slope and $|m| > 1$. [2+8]
3. Given a clipping window A (10, 10), B (40,40), C(40,40) and D(10,40). Using cohen-sutherland line clipping algorithm find region code of each end points of lines P1P2, P3P4 and P5P6 where co-ordinates are P1 (5,15), P2(25,30), P3(15,15), P4(35,30), P5(5,8) and P6(40,15). Also find clipped lines using above parameters. [10]
4. Perform rotation of a line (10, 10, 10), (20, 20, 15) about Y-axis in clock wise direction by 90 degree. Explain about vector display. [6+4]
5. Derive the equation for cubic Bezier curve. Also write down its properties. [8]
6. Explain how the 3D object is represented using polygon table representation technique? Explain any one technique to calculate the spatial orientation of the individual surface component of 3D object. [4+4]
7. Describe scan line method to find visible lines with example. [10]
8. Under what condition(s) flat shading gives accurate rendering? Mention the disadvantage of intensity interpolation technique and explain Phong shading with necessary mathematical calculation. Explain the diffuse reflection. [3+1+6+4]
9. Why GLUT is implemented in OpenGL? Explain OpenGL syntax to draw a parallelogram having vertices (0.0, 0.0), (1.0, 0.0), (1.5, 1.2) and (0.5,1.2). [2+4]

34 TRIBHUVAN UNIVERSITY
INSTITUTE OF ENGINEERING
Examination Control Division
2070 Chaitra

Exam.	Regular		
Level	BE	Full Marks	80
Programme	BEX, BCT	Pass Marks	32
Year / Part	III / I	Time	3 hrs.

Subject: - Computer Graphics (EX603)

- ✓ Candidates are required to give their answers in their own words as far as practicable.
 - ✓ Attempt All questions.
 - ✓ The figures in the margin indicate Full Marks.
 - ✓ Assume suitable data if necessary.
1. How much time is spent scanning across each raw of pixels during screen refresh on a raster system with resolution 1024×768 and a refresh rate of 60 frames per second? [4]
 2. Mention the disadvantages of DDA method. Write the complete Bresenham's line drawing algorithm and using midpoint circle drawing algorithm calculate the co-ordinate on the first quadrant of a circle having radius 6 and centre (20,10) [2+4+4]
 3. State the conditions of point clipping. Perform clipping operation for the following using Liang Barskey line clipping algorithm: [2+6]

Clipping window: (Xmin, Ymin) = (2,5) and (Xmax, Ymax) = (35,50)

Line: (x1, y1) = (-2,2) and (x2,y2) = (45,40)
 4. Define window and view port. Describe three dimension windows to view port transformation with matrix representation for each step. Derive oblique projection matrix with necessary assumptions. [1+4+5]
 5. Define Hermite Interpolation in defining a curve. Use it to find the blending function of a parametric cubic curve in 2D graphics. [2+6]
 6. Describe polygon, Vertex and Edge table of polygon. How these terms are important in computer graphics. [8]
 7. Describe z-buffer method for visible surface detection in detail. State its limitation and recommended method that addresses it. [7+3]
 8. Calculate the total intensity using Phong reflection model by considering all type of light sources. [8]
 9. Compare and Contrast between Gouraud and Phong Shading Model. [8]
 10. Write short notes on: [3×2]
 - a) Call back function
 - b) Open GL

Exam.	Regular		
Level	BE	Full Marks	80
Programme	BEX, BCT	Pass Marks	32
Year / Part	III / I	Time	3hrs.

Subject: - Computer Graphics (EX603)

- ✓ Candidates are required to give their answers in their own words as far as practicable.
 - ✓ Attempt All questions.
 - ✓ The figures in the margin indicate Full Marks.
 - ✓ Assume suitable data if necessary.
1. Derive decision parameters for midpoint circle algorithm assuming the start position as $(r, 0)$ and points are to be generated along the curve path in counter clock wise order. What is symmetry property? [8+2]
 2. Explain the two dimensional viewing pipeline. Derive the 2D transformation matrix for scaling with respect to an arbitrary fixed point. [4+6]
 3. How can you perform three dimensional rotations of an object about some arbitrary axis? Explain. [8]
 4. What is Geometric table? Construct a Geometric table for considering an object having 3 surfaces formed from 6 vertices and 8 edges. [2+6]
 5. How can you model a curved surface using polygons only? Explain the use of polygon tables for boundary representations. [3+5]
 6. What is the difference between object space method and image space method for visible surface determination? Explain the Z-buffer method for visible surface determination. [3+7]
 7. Explain the Phong illumination model for specular reflection. [7]
 8. Explain the Gouraud Shading intensity-interpolation scheme for polygon-rendering. [7]
 9. Why open GL required? Explain with examples. [6]
 10. Write short notes on: [2×3]
 - a) Applications of computer graphics
 - b) Two-point perspective projection

Exam.	Regular		
Level	BE	Full Marks	80
Programme	BEX, BCT	Pass Marks	32
Year / Part	III / I	Time	3 hrs.

Subject: - Computer Graphics (EX 603)

- ✓ Candidates are required to give their answers in their own words as far as practicable.
- ✓ Attempt All questions.
- ✓ The figures in the margin indicate Full Marks.
- ✓ Assume suitable data if necessary.

1. What is the size of frame buffer required to store a SVGA with 24 bit true color video of 10 min without compression? [4]
2. Digitize the endpoint (10, 18), (15, 8) using Bresenham's algorithm. [8]
3. find the composite transformation matrix for reflection about a line $y = mx + c$. [8]
4. Find the new coordinates of a unit cube 90°-rotated about an axis defined by its endpoints A(2,1,0) and B(3,3,1). [8]
5. Why 3D graphics is more complex than 2D graphics? Explain with the help of viewing pipeline. [8]
6. Explain about parametric cubic curve? What is a Bezier Curve? Explain its properties. [3+3+2]
7. Explain how the geometric and attribute information of a three dimensional objects are stored for the object representation? What are the conditions for error free generation of polygon table? [5+3]
8. Differentiate between image space and object space methods of visible surface detection. Describe A-Buffer method of visible surface detection. [4+6]
9. Explain the Gourad shading for polygon-rendering and compare it with phong shading. [8+2]
10. Write short notes on: (any two) [4×2]
 - a) Specular Reflection
 - b) Midpoint circle decision parameter
 - c) Application of OpenGL in Computer Graphics

Exam.	Regular / Back		
Level	BE	Full Marks	80
Programme	BEX, BCT	Pass Marks	32
Year / Part	III / II	Time	3 hrs.

Subject: - Computer Graphics

- ✓ Candidates are required to give their answers in their own words as far as practicable.
- ✓ Attempt All questions.
- ✓ The figures in the margin indicate Full Marks.
- ✓ Assume suitable data if necessary.

1. Write Bresenham's line algorithm (you may assume $|m| < 1$). How the demerit of DDA algorithm is corrected in Bresenham's algorithm? [7+3]
2. Calculate all pixels of a circle in the first octant, proceeding to positive X axis direction. The radius = 30 and center at (10, 20). [10]
3. Perform scaling transformation to the triangle with vertices A (6, 9), B (10, 5), C (4, 3) with scaling factors $S_x = 3$ and $S_y = 2$. [Show the necessary transformation matrix] [10]
4. How do you perform shearing operations in 3-D in different directions? Discuss with necessary shear matrix. [10]
5. Formulate a matrix that converts 3-D scene described in world coordinates to viewing coordinates. [10]
6. What are the object space and image space method of hidden surface removal? Describe back face detection method of hidden surface removal. [4+6]
7. Discuss a constant intensity shading method. Mention the advantage of Phong shading over Gouraud shading. [7+3]
8. Write short notes on: (any two) [5+5]
 - a). Raster display and vector display system
 - b). 2-D viewing pipeline.
 - c). Plasma display

TRIBHUVAN UNIVERSITY
 INSTITUTE OF ENGINEERING
Examination Control Division
 2079 Bhadra

Exam.	Regular		
Level	BE	Full Marks	80
Programme	BCT	Pass Marks	32
Year / Part	III / I	Time	3 hrs.

Subject: - Data Communication (CT 602)

- ✓ Candidates are required to give their answers in their own words as far as practicable.
- ✓ Attempt All questions.
- ✓ The figures in the margin indicate Full Marks.
- ✓ Assume suitable data if necessary.

1. Define Data and Signal with examples. Sketch a generic block diagram of digital data communication system for full duplex mode. [2+6]
2. Define a causal system and a stable system. Check whether a system $y(t) = x(t) + x(t - 1)$ is (i) linear (ii) time-invariant (iii) causal (iv) memoryless system [2+6]
3. State properties of continuous time Fourier Transform. [4]
4. Find convolution between two signals $x_1(t) = u(t) - u(t-3)$ and $x_2(t) = u(t + 4) - u(t)$. [4]
5. State and explain theorem for noisy and noiseless channel. Briefly discuss about the measures that are used to characterize the performance of channel. [4+4]
6. a) Why we need modulation? A modulating signal, $m(t) = 10 \cos(2\pi \times 10^3 t)$ is amplitude modulated with carrier signal, $c(t) = 50 \cos(2\pi \times 10^5 t)$. Find the modulation index, the carrier power and the power required for transmitting AM wave. [2+6]
 b) Encode the bit stream 101110001010 using NRZ-L, NRZ-I, Manchester, Bipolar AMI. [4×2]
7. a) Discuss briefly on Spread Spectrum communication with neat block diagram. [4]
 b) What are the two basic approaches commonly used to packet switching? [4]
 c) Compare all three types of multiplying technique with the application case of each. [8]
8. a) Apply the Huffman coding procedure to determine Entropy, Average Code length, code efficiency and Redundancy for the following message ensemble $[x] = [x_1, x_2, x_3, x_4, x_5, x_6]$ and $[p] = [0.30, 0.25, 0.15, 0.12, 0.08, 0.10]$, Take $M = 2$ [8]
 b) For a (6, 3) code, the generator matrix is

$$G = \begin{bmatrix} 1 & 0 & 0 & 1 & 0 & 1 \\ 0 & 1 & 0 & 0 & 1 & 1 \\ 0 & 0 & 1 & 1 & 1 & 0 \end{bmatrix}$$
 Find (i) All corresponding code vectors (ii) Minimum Hamming distance (iii) Verify that this code is a single error correcting code (iv) Parity check matrix (v) Determine transmitted codeword if received code is 100011. [8]

Exam.	Back		
Level	BE	Full Marks	80
Programme	BCT	Pass Marks	32
Year / Part	III / I	Time	3 hrs.

Subject: - Data communication (CT 602)

- ✓ Candidates are required to give their answers in their own words as far as practicable.
- ✓ Attempt All questions.
- ✓ The figures in the margin indicate Full Marks.
- ✓ Assume suitable data if necessary.

1. What are the different types of data transmission technology? Mention advantage and disadvantage of analog and digital communication system. [4+6]

2. a) A system's output is given as:
 $y(t) = 2x(t) + 3$, where $x(t)$ is its input. Determine whether the system is LTI or not. [5]
 - b) Obtain the Fourier transform of a DC signal whose amplitude is unity at all time instants, and hence, plot its magnitude and phase spectrum. [5]
 - c) Mention any two applications of Fourier series. [2]

3. The equation of amplitude modulated wave is given by $s(t) = 40 [1 + 0.8\cos(2\pi \times 10^3 t)] \cos(4\pi \times 10^5 t)$. Find the carrier power, the total sideband power and bandwidth of the signal. The value of resistor given is 30 ohm. [4+4+2]

4. What are the needs of line coding in data communication? Given the binary data sequence 1101110111 represent it in unipolar NRZ, polar RZ, Manchester and AMI waveform. [2+2+2+2]

5. Define multiplexing and write its application system. Explain the operation of TDM and FDM clearly with diagram. [2+4+4]

6. What is Spread Spectrum? Explain frequency hopping spread spectrum and direct sequence spread spectrum with its block diagram. [4+6]

7. Define block codes. The systematic generator matrix for a (6,3) block code is given below. Obtain all code words, Hamming weights and minimum hamming distance from this matrix. [2+4+2+2]

$$G = \begin{bmatrix} 1 & 0 & 0 & 0 & 1 & 1 \\ 0 & 1 & 0 & 1 & 0 & 1 \\ 0 & 0 & 1 & 1 & 1 & 0 \end{bmatrix}$$

8. Calculate coding efficiency of "Khoji Rahechha Desh Le Yek Yug Nayak" using Huffman coding technique. [10]

TRIBHUVAN UNIVERSITY
 INSTITUTE OF ENGINEERING
Examination Control Division
 2078 Bhadra

Exam.	Regular		
Level	BE	Full Marks	80
Programme	BCT	Pass Marks	32
Year / Part	III / I	Time	3 hrs.

Subject: - Data Communication (CT 602)

- ✓ Candidates are required to give their answers in their own words as far as practicable.
- ✓ Attempt All questions.
- ✓ The figures in the margin indicate Full Marks.
- ✓ Assume suitable data if necessary.

1. Differentiate between energy and power signals with examples. Determine if the following system is stable LTI. [5+5]
 $Y(t) = x(t^2)$
2. List and describe all data communication parameters that describe the performance of the system. [8]
3. Explain how we plot line spectrums of a continuous time signal and illustrate an example. [8]
4. Encode 11100000000000011 using B8ZS and HDB3 encoders. [10]
5. Demonstrate how checksum is used to detect errors while sending a data word of 12, 15, 15, 10, 5, 2. [8]
6. a) Explain the working principle of FHSS technique. [5]
 b) Explain how CDMA works with example. [5]
7. What are linear block codes? Design a code word of a C(8, 4) block code with any suitable generation matrix. [8]
8. Encode "Jasta lai tastai dhido lai nistai" using weighted Huffman encoder. Also demonstrate how it is decoded. [10]
9. Describe with short notes on: (Any Two) [2×4]
 - a) Double-tone AM
 - b) Hamming codes
 - c) Packet switching versus message switching
 - d) X.25 protocol

TRIBHUVAN UNIVERSITY
INSTITUTE OF ENGINEERING
Examination Control Division
2078 Kartik

Exam.	Back		
Level	BE	Full Marks	80
Programme	BCT	Pass Marks	32
Year / Part	III / I	Time	3 hrs.

Subject: - Data Communication (CT 602)

- ✓ Candidates are required to give their answers in their own words as far as practicable.
 - ✓ Attempt All questions.
 - ✓ The figures in the margin indicate Full Marks.
 - ✓ Assume suitable data if necessary.
1. a) Differentiate data and signal with two examples of each. [5]
 b) Explain the procedure of converting an analog signal to digital. Also, briefly explain each steps involved. [5]
 2. Define periodic and non-periodic signals with examples. [2+4+4]
 a) Test the stability of the system $h(t) = e^{4t} \cdot u(t)$
 b) Test the given function $y(t) = t \cdot x(t)$ for causality, non causality and anti causality.
 3. How Nyquist theorem applied for a noiseless channel? Calculate number of discrete signal content in the channel if a channel has a spectrum of 3 to 4 MHz with signal to noise ratio of 24 dB. [5+5]
 4. Explain the operation of CRC-4 with example of error detection. [10]
 5. Define line coding. Explain polar RZ and bipolar AMI line coding scheme with example and compare them. [4+3+3]
 6. a) How is source coding different from channel coding? [2]
 b) Under what conditions does a linear code become a cyclic code? Explain with the help of an example. [3]
 c) Explain the concept of convolutional code with the help of a state-transition diagram. [5]
 7. Write down the Huffman Algorithm clearly and find an efficient code word and efficiency that can be assign to the symbols using Huffman Algorithm for "Kun Mandir Ma Janchhau Yattri". [10]
 8. a) Explain the mechanism of frequency Hopping spread spectrum (FHSS). Also, compare FDM and FHSS using suitable time-frequency graph. [4+3]
 b) Explain the "near-far problem" in CDMA. How can it be solved? [2+1]

TRIBHUVAN UNIVERSITY
INSTITUTE OF ENGINEERING
Examination Control Division
2076 Chaitra

Exam.	Regular		
Level	BE	Full Marks	80
Programme	BCT	Pass Marks	32
Year / Part	III / I	Time	3 hrs.

Subject: - Data Communication (CT 602)

- ✓ Candidates are required to give their answers in their own words as far as practicable.
- ✓ Attempt All questions.
- ✓ The figures in the margin indicate Full Marks.
- ✓ Assume suitable data if necessary.

1. Draw a generic block diagram of a digital communication system used in mobile telephony and explain each block. Compare analog and digital communication system with examples. [6+2]
2. Explain the properties of causal, non-causal and anticausal systems with example. [10]
3. Explain why we need Fourier Transform. Plot the line spectrums of $X(t) = 12 + 6\sin(140\pi t + 30^\circ) - 9\cos(80\pi t - 70^\circ)$. [5+5]
4. Why we need Modulation? Illustrate an example of a 4-bit PCM with AMI encodes. [2+6]
5. Demonstrate how CRC-5 works to detect errors in data communication. [8]
6. What is multiplexing? Compare synchronous and statistical TDM. Describe Frequency hopping spread spectrum and direct sequence spread spectrum with its block diagram. [2+4+4]
7. Construct a (7, 4) Hamming code using a 4×4 generation matrix for any arbitrary message. [8]
8. Encode "Phool ko aankhama phoolai sansara" using Huffman encoder and find the transmission efficiency. [10]
9. Write short notes on: (Any two) [4×2]
 - a) STP versus UTP
 - b) Frame relay
 - c) 16-Quadrature amplitude modulation
 - d) Multi mode optical fiber

TRIBHUVAN UNIVERSITY
 INSTITUTE OF ENGINEERING
Examination Control Division
 2076 Ashwin

Exam.	Back		
Level	BE	Full Marks	80
Programme	BCT	Pass Marks	32
Year / Part	III / I	Time	3 hrs.

Subject: - Data Communication (CT 602)

- ✓ Candidates are required to give their answers in their own words as far as practicable.
- ✓ Attempt **All** questions.
- ✓ The figures in the margin indicate **Full Marks**.
- ✓ Assume suitable data if necessary.

1. Enlist the advantages and disadvantages of digital communication system over analog communication system. Discuss the transmission impairments of data communication system with suitable diagrams and suggest the methods in overcoming attenuation. [3+5]
2. What are properties Fourier transform? Plot the magnitude and phase spectra of $X(t) = 5 + \sin(12t + 20^\circ) - \cos(16t - 60^\circ) + \cos(20t + 40^\circ)$. [4+4]
3. Sketch the output of LTI system having impulse response $h(t) = e^{-at}u(t)$ ($a > 0$) and $h(t) = e^{at}u(-t)$ ($a > 0$). [10]
4. List different types of digital-to-analog line encoding techniques. Give an example of QAM-32 in its constellation diagram. [2+6]
5. Explain with example how CRC-5 work to detect 3 burst errors. [10]
6. Define Frequency division Multiplexing. Explain the FDM Multiplexing and demultiplexing process with neat diagrams. [8]
7. Design a suitable generation matrix for a convolution code using $c(3,1,3)$ architecture and encode input data stream of (00110). [10]
8. Design a Binary Shannon-Fano code with a six symbol source with probability assignment as $P(s_1)=0.04$, $P(s_2)=0.1$, $P(s_3)=0.1$, $P(s_4)=0.4$, $P(s_5)=0.06$, $P(s_6)=0.3$. Test its transmission efficiency. [7+3]
9. Write short notes on: (**Any Two**) [4×2]
 - a) Analog versus digital mux hierarchy
 - b) DSSSS versus FSSS
 - c) Optical fiber versus STP

TRIBHUVAN UNIVERSITY
 INSTITUTE OF ENGINEERING
Examination Control Division
 2075 Chaitra

Exam.	Regular / Back		
	Level	BE	Full Marks
Programme	BCT	Pass Marks	32
Year / Part	III / I	Time	3 hrs.

Subject: - Data Communication (CT 602)

- ✓ Candidates are required to give their answers in their own words as far as practicable.
- ✓ Attempt All questions.
- ✓ The figures in the margin indicate Full Marks.
- ✓ Assume suitable data if necessary.

1. Sketch a generic block diagram of digital data communication system for full duplex mode. [8]
2. Distinguish between power and energy signals with examples. [8]
3. State the condition for the stability of LTI system. Test the stability of the system whose impulse response is $h(t)=te^{-3t}u(t)$ [8]
4. List digital- to-digital line encoding techniques and explain in detail Bipolar 8-zero substitution and High Density 3-zero substitution techniques. [2+4+4]
5. With suitable mathematical expression, explain double-tone AM technique. [8]
6. Demonstrate how CRC-4 works to trace two burst errors. [10]
7. Differentiate between digital and analog spread spectrum techniques using examples. [8]
8. Define entropy in information theory. Find the efficient code word and efficiency using Hoffman algorithm using probabilities $p(x_1)=0.6$, $p(x_2)=0.2$, $p(x_3)=0.1$, $p(x_4)=0.05$, $p(x_5)=0.05$. [8]
9. Explain why channel coding is required in data communication. Generate a convolution code for a input bit streams of (111011) using a $c(3,1,3)$ architecture. [2+10]

Exam.	Back		
Level	BE	Full Marks	80
Programme	BCT	Pass Marks	32
Year / Part	III / I	Time	3 hrs.

Subject: - Data Communication (CT602)

- ✓ Candidates are required to give their answers in their own words as far as practicable.
- ✓ Attempt All questions.
- ✓ The figures in the margin indicate Full Marks.
- ✓ Assume suitable data if necessary.

1. Describe the transmission impairments of data communication system with suitable example. [6]
2. Define periodic and non-periodic signals with examples. Determine whether the following signals are periodic or not. [2+3+3]
 - a) $X(t) = \sin 15\pi t$
 - b) $x(t) = \sin \sqrt{2}\pi t$
3. What are Recursive and Nonrecursive system? Test the stability of the CTI system whose impulse response is given as: $h(t) = e^{-t} \sin(t) u(t)$ [3+5]
4. State and explain Shannon-Hartley channel capacity theorem with example. Briefly discuss about the measures that are used to characterize the performance of a channel. [4+4]
5. a) An audio frequency signal $10 \sin 1000\pi t$ is used for a single tone amplitude modulation with a carrier of $50 \sin 2\pi \times 10^3 t$. Calculate :
 - (i) Modulation index
 - (ii) Bandwidth requirement
 - (iii) Total power delivered if load = 60Ω [2×3]
- b) Encode the bit stream 10010110001 using the following encoding schemes:
 - (i) Polar NRZ-L
 - (ii) Polar NRZ-I
 - (iii) Differential Manchester [2×3]
6. a) Explain, how spread spectrum techniques like FHSS and DSSS work? [6]
- b) Explain the operation of packet switching system. [4]
7. Considering a $\frac{1}{2}$ rate, 4-state convolutional code, correct 3 bits errors using the help of its trellis diagram. [10]
8. Explain QAM with its transmitter circuit and draw any one constellation diagram for 32-QAM. [6+2]
9. The source of information symbols $\{A_0, A_1, A_2, A_3 \text{ and } A_4\}$ have corresponding probabilities $\{0.4, 0.3, 0.15, 0.1 \text{ and } 0.5\}$. Encode the source symbols using most efficient coding scheme and calculate the corresponding efficiency. [10]

Exam.	Regular		
Level	BE	Full Marks	80
Programme	BCT	Pass Marks	32
Year / Part	III / I	Time	3 hrs.

Subject: - Data Communication (CT602)

- ✓ Candidates are required to give their answers in their own words as far as practicable.
- ✓ Attempt All questions.
- ✓ The figures in the margin indicate Full Marks.
- ✓ Assume suitable data if necessary.

1. Draw a generic block diagram of digital communication system for full duplex mode and briefly explain the function of each block. [8]
2. Derive an expression to find even and odd part of signal $x(t)$. Find even and odd part of a signal $x(t) = 0.5(t+1)$ for $-1 \leq t \leq 1$. [4+4]
3. State the properties of continuous time Fourier series. [6]
4. Define LTI system. Determine the range of values of "a" and "b" for the stability of LTI system with impulse response. $h(t) = e^{at} u(t) + e^{-bt} u(t)$ [3+5]
5. A single tone FM is represented by the voltage equation as $v(t) = 12\cos(6 \times 10^8 t + 5\sin 1250t)$. Determine following: [8]
 - a) Carrier frequency
 - b) Modulating frequency
 - c) Modulation index
 - d) Maximum frequency deviation
6. Applying a $\frac{1}{2}$ rate, 4-state convolutional code correct errors of two bits with the help of its trellis diagram. [8]
7. What is multiplexing and why we need it? Explain FDM hierarchy in telephone system. [3+5]
8. What is CRC? Explain 3 bit CRC generator and decoder with example of no error case. [2+6]
9. Write down the Huffman Algorithm clearly. Find an efficient code word and calculate efficiency that can be assign to the symbols using Huffman Algorithm using probabilities $p(x_1) = 0.5, p(x_2) = 0.25, p(x_3) = 0.125, p(x_4) = 0.125$. [4+4]
10. Write short notes on: (Any two) [2×5]
 - a) Means of Band width utilization
 - b) Data communication impairments
 - c) B8ZS

Exam.	Back		
Level	BE	Full Marks	80
Programme	BCT	Pass Marks	32
Year / Part	III / I	Time	3 hrs.

Subject: - Data Communication (CT602)

- ✓ Candidates are required to give their answers in their own words as far as practicable.
- ✓ Attempt All questions.
- ✓ The figures in the margin indicate Full Marks.
- ✓ Assume suitable data if necessary.

1. Define transmission Impairment. Compare analog communication system with digital communication system with appropriate block diagram for half-duplex mode. [4+6]
2. Explain the linearity and time invariance property of a system with example. Check whether the following system is linear, time invariant and causal or not. [5+3]
 $y(t) = x(t-2) + x(2-t)$
3. Find the output of LTI system having impulse response $h(t) = e^{-2t}; t > 0$ to the input. [8]

$$x(t) = \begin{cases} 0 & \text{for } t < 0 \\ 1 & \text{for } 0 \leq t \leq 1 \\ 0 & \text{for } 1 < t \end{cases}$$

4. a) What are the advantages of optical fibers over coaxial cable and twisted pair cable? [3]
 b) State Nyquist's and Shannon's channel capacity formula. Find the Capacity of a channel for a signal with a bandwidth of 3.1 KHz and Signal to Noise ratio of 0 dB and comment on it. [2+3+3]
5. Encode the bit stream 1010011001 using NRZ-L, NRZ-I, RZ, Manchester, Bipolar AMI encoding technique. [2×5]
6. a) Define multiplexing with example. Compare synchronous and asynchronous TDM. [3+3]
 b) Generate a CRC-3 transmission code and analyze its error detection performance with example.
7. Explain the rate of switching and compare circuit switching with packet switching. [2+5]
8. Consider a five symbol source with probability assignment as $P(X_1) = 0.2, P(X_2) = 0.35$
 $P(X_3) = 0.1, P(X_4) = 0.2, P(X_5) = 0.15$. By using Huffman algorithm, find the source code for these symbols and determine efficiency of the code. [10]
9. Describe with short notes: (any two) [2×5]
 - i) HD3S coding
 - ii) Packet switching
 - iii) Designing a codeword of a c(6,3) block code with any suitable generation matrix

Exam.	Regular		
	Level	BE	Full Marks
Programme	BCT	Pass Marks	32
Year / Part	III / I	Time	3 hrs.

Subject: - Data Communication (CT602)

- ✓ Candidates are required to give their answers in their own words as far as practicable.
- ✓ Attempt All questions.
- ✓ The figures in the margin indicate Full Marks.
- ✓ Assume suitable data if necessary.

1. Define analog and digital signal with example. Explain digital communication system with general block diagram for full-duplex mode. [2+6]
2. Explain deterministic and random signal with example. Justify whether unit step signal is energy signal or power signal. [4+4]
3. Define LTI system. Find convolution between $x(t) = u(t)$ and $h(t) = u(t)$ and comment on the result. [2+5+1]
4. Why we need Fourier transform even we have Fourier series? State and explain briefly about the properties of Fourier transform. [2+6]
5. Generate a codeword of a $c(6,3)$ block code with any suitable generation matrix. [6]
6. An audio signal of $10\sin 1000\pi t$ is used for AM with a carrier of $50\sin 200000\pi t$. [2+2+2+2]
 Calculate:
 - i) Modulation index
 - ii) Required bandwidth
 - iii) Total power using load resistance of 800 ohm
 - iv) Efficiency of AM
7. For a binary data sequence 1111000111 sketch (a) NRZ-I waveform, (b) AMI waveform, (c) RZ waveform and (d) Manchester waveform. [2+2+2+2]
8. What is spread spectrum? Explain Frequency Hopping Spread Spectrum and Direct Sequence Spread Spectrum with its block diagram. [2+6]
9. A message source generates 8 symbols with the following probabilities $P(x_1) = 1/2$, $P(x_2) = 1/4$, $P(x_3) = 1/8$, $P(x_4) = 1/16$, $P(x_5) = 1/32$, $P(x_6) = 1/64$, $P(x_7) = 1/128$, $P(x_8) = 1/128$. Encode the message with variable length binary codes using Shannon-Fano procedure. Find the transmission efficiency. [8]
10. Write short notes on: (any two) [5×2]
 - i) UTP versus STP
 - ii) E-Hierarchy versus T-Hierarchy
 - iii) Convolutional codes.

Exam.	New Back (2066 & Later Batch)		
Level	BE	Full Marks	80
Programme	BCT	Pass Marks	32
Year / Part	III / I	Time	3 hrs.

Subject: - Data Communication (CT602)

- ✓ Candidates are required to give their answers in their own words as far as practicable.
- ✓ Attempt All questions.
- ✓ The figures in the margin indicate Full Marks.
- ✓ Assume suitable data if necessary.

1. Draw generic block diagram of digital communication duplex system and explain each block. Write down the advantages and disadvantages of digital communication over analog communication system. [5+3]
2. Define LTI system. Compute convolution between two signals $x(t) = e^{-at} \cdot u(t)$ ($a > 0$) and $h(t) = e^{at} \cdot u(-t)$ ($a > 0$) and plot the resulting signal. [3+6+1]
3. Check linearity, causality, stability and time invariance characteristics of system $y(t) = 2x(t+1)$ [6]
4. Identify and discuss different data transmission channels. How synchronous transmission differs from asynchronous transmission? [4+4]
5. What is Frequency modulation (FM)? Explain with suitable equations and waveforms. [2+4]
6. Define multiplexing. Compare the merits and demerits of synchronous TDM and statistical TDM method. [2+6]
7. What is Data Switching? Clarify the differences between datagram switching and virtual packet switching. [2+6]
8. Where convolution codes are used? Describe a convolution codes with $\frac{1}{2}$ rate. [2+6]
9. What do you mean by entropy? Describe linear block coding method with a suitable example for detection of an error. [2+6]
10. Explain the general working principle of Binary Huffman Coding Algorithm. Design a Binary Huffman code with a six symbol source with probability assignment as: $P(s_1)=0.0$, $P(s_2)=0.1$, $P(s_3)=0.1$, $P(s_4)=0.4$, $P(s_5)=0.06$ and $P(s_6)=0.3$. [4+6]

Exam.	Regular		
Level	BE	Full Marks	80
Programme	BCT	Pass Marks	32
Year / Part	III / I	Time	3 hrs.

Subject: - Data Communication (CT602)

- ✓ Candidates are required to give their answers in their own words as far as practicable.
- ✓ Attempt All questions.
- ✓ The figures in the margin indicate Full Marks.
- ✓ Assume suitable data if necessary.

1. Describe the Transmission Impairments of Data Communication system with suitable examples. [6]
2. Define stable and unstable systems. Test the stability of the LTI systems whose impulse responses are given as (i) $h(t) = e^{at}u(t)$ (ii) $h(t) = e^{-at}u(t)$ [2+3+3]
3. Distinguish between energy and power signal with an example. Justify whether a signal $x(t) = e^{-at}u(t)$ ($a > 0$) is energy or power signal. [4+4]
4. State and explain Shannon-Hartley channel capacity theorem. Briefly discuss about the measures that are used to characterize the performance of a channel. [4+4]
5. Encode the Bit Stream 10110001110 using the following scheme. [10]
 - a) RZ
 - b) NRZ-I
 - c) NRZ-L
 - d) AMI
 - e) Manchester
6. What do you mean by multiplexing? Explain about working mechanism of FDM and TDM. [2+3+3]
7. Differentiate between circuit switching and packet switching with suitable diagram. [6]
8. What are block codes? The generator matrix for a (6,3) block code is shown below. Obtain all code words. [2+8]

$$G = \begin{bmatrix} 1 & 0 & 0 & : & 1 & 1 & 1 \\ 0 & 1 & 0 & : & 1 & 1 & 0 \\ 0 & 0 & 1 & : & 1 & 0 & 1 \end{bmatrix}$$
9. What are Hamming codes? Write the properties of Hamming codes. Visualize a 3-bit code words as code vector. [2+4+4]
10. A message source generates 8 symbols with the following probabilities: [6]

$$P(X_1) = 1/2, P(X_2) = 1/4, P(X_3) = 1/8, P(X_4) = 1/16, P(X_5) = 1/32, P(X_6) = 1/64$$

$$P(X_7) = 1/128 \text{ and } P(X_8) = 1/128.$$
 Encode the message using Huffman code.

Exam.	New Back (2066 & Later Batch)		
Level	BE	Full Marks	80
Programme	BCT	Pass Marks	32
Year / Part	III / I	Time	3 hrs.

Subject: - Data Communication (CT602)

- ✓ Candidates are required to give their answers in their own words as far as practicable.
- ✓ Attempt All questions.
- ✓ The figures in the margin indicate Full Marks.
- ✓ Assume suitable data if necessary.

1. Differentiate between causal and anticausal signals with examples. Determine the power and energy for a continuous time signal of $x(t) = e^{-2t}u(t)(t \geq 0)$ [6+4]
2. Define periodic and non-periodic signals. Determine if the following systems are linear, time-invariant, stable and memoryless. [2+3+3]
 - a) $y(t) = [1 - e^{-4t}][U(t)]$ where $U(t)$ is the continuous-time unit step function
 - b) $y[k] = \sin(x[k - 4])$
3. Define LTI system and impulse response. For the given signal $x(t) = e^{-at}u(t)(a > 0)$, find and plot the magnitude and phase spectra. [2+2+6]
4. Briefly discuss about the measures used to characterize the performance of a channel. State Nyquist's and Shannon's channel capacity formula. [2+2]
5. Define Throughput and Latency. Explain about different types of propagation. [3+5]
6. Design (a) RZ (b) NRZ-L (c) NRZ-I (d) AMI waveforms for the data sequences of 111100011100110. [10]
7. Define multiplexing and list out its applications. Draw block diagram of Frequency Hopping Spread Spectrum transmitter and receiver and explain briefly. [4+6]
8. Differentiate between datagram switching and virtual circuit switching technique. Discuss packet switching taking example of X.25 protocol in detail. [5+5]
9. Show the application of hamming distance with suitable example. [4]
10. Write short notes on: [3×2]
 - i) Linear block coding
 - ii) Huffman loading

Exam.	Regular		
Level	BE	Full Marks	80
Programme	BCT	Pass Marks	32
Year / Part	III / 1	Time	3 hrs.

Subject: - Data Communication (CT602)

- ✓ Candidates are required to give their answers in their own words as far as practicable.
- ✓ Attempt All questions.
- ✓ The figures in the margin indicate Full Marks.
- ✓ Assume suitable data if necessary.

1. Define noise. Briefly discuss the types of noise. Define thermal noise power density; calculate the thermal noise power density in Watts/Hz at a temperature of 17°C, the Boltzmann's constant is 1.38×10^{-23} J/K. What is delay distortion and how can it be corrected? Why is digital transmission preferred over analog transmission? [4+2+2]
2. Define energy and power signal. Check the signal $x(t) = u(t)$ and $x(t) = \delta(t)$ is Energy or Power type. [1+4]
3. Define Linear, Stable, Time Invariant and Causal system with suitable examples. [4]
4. Find the Fourier series representation of the half-wave rectified Sine wave. [4]

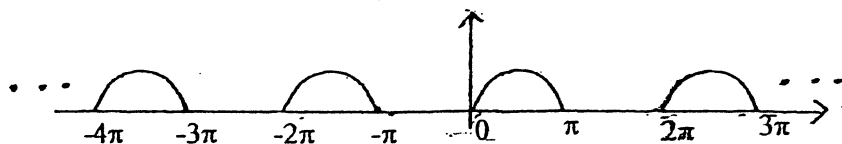

5. Find the Fourier transform of the signal $x(t) = e^{-a|t|}$, where $(0 < a < \infty)$ is real-valued and $|t|$ denotes the absolute value of (t) . Define the terms linear time-invariant (LTI) systems and impulse response. [4+2]
6. Compare the transmission characteristics and performance (frequency range, bandwidth, security, flexibility, interference, connectivity) of Optical fiber cable and Satellite transmission. [6]
7. Given a channel with an intended capacity of 40 Mbps. The bandwidth of the channel is 6 MHz. What signal-to-noise ratio is required in order to achieve this capacity? Also find number of bits/sample if channel becomes noiseless. [3+2]
8. Explain the working of Pulse Code Modulation (PCM). Draw AMI and Manchester encoding for the sequence [0 1 1 0 1 0 0 0 1]. [4+3+3]
9. Define multiplexing. Explain the working mechanism of WDM. Differentiate between synchronous and statistical TDM. How is spread spectrum utilized in CDMA? What are the advantages and disadvantages of CDMA? [2+2+2+2+2]
10. How does-ATM differ from frame relay? What are the advantages and disadvantages of ATM compared to frame relay? [2+3]
11. Why is source coding necessary? Differentiate between fixed length codes and variable length codes. What is the purpose of Huffman's coding algorithm? Explain the general working principle of the Huffman coding algorithm. [1+1+1+3]
12. Define Dataword and Codeword with suitable example. List the error detection and correction coding techniques with their application case. [2+4]
13. Discuss the concept of redundancy in error detection and correction. Define Hamming distance? Differentiate between linear block codes and cyclic codes. [1+1+3]

Exam.	New Back (2066 & Later Batch)		
Level	BE	Full Marks	80
Programme	BCT	Pass Marks	32
Year / Part	III / I	Time	3 hrs.

Subject: - Data Communication (CT602)

- ✓ Candidates are required to give their answers in their own words as far as practicable.
- ✓ Attempt All questions.
- ✓ The figures in the margin indicate Full Marks.
- ✓ Assume suitable data if necessary.

1. Explain digital communication system with general block diagram. Explain the advantages of digital communication system over analog communication system. [6+2]
2. Explain the basic properties of systems with examples. [8]
3. Define unit impulse and unit step function. Obtain the Fourier transform of a single sided exponential function $e^{-at} \cdot u(t)$. Also draw the spectrum. [2+5+3]
4. Compare guided and unguided transmission media. Calculate the channel capacity having bandwidth and SNR of 6 kHz and 6 db respectively. [5+3]
5. Define modulation. Why is it necessary? Encode the bitstream 10101111000011 using NRZ, RZ, AMI and Manchester coding. [4+4]
6. Explain Quadrature Amplitude Modulation (QAM) with transmitter and receiver block diagram. [8]
7. What are the differences between multiplexing and multiple access? Define Time Division multiplexing (TDM) and explain it briefly. [3+5]
8. Define switching. Compare circuit and packet switching. Draw the X.25 layers and data formats. [7]
9. Define Information, Entropy and Minimum Hamming Distance with examples. [2+2+2]
10. Define cyclic code. Explain the procedure for determining code vector for linear block code. [3+6]

Exam.	Regular		
Level	BE	Full Marks	80
Programme	BCT	Pass Marks	32
Year / Part	III / I	Time	3 hrs.

Subject: - Data Communication (CT602)

- ✓ Candidates are required to give their answers in their own words as far as practicable.
- ✓ Attempt All questions.
- ✓ The figures in the margin indicate Full Marks.
- ✓ Assume suitable data if necessary.

1. Differentiate between digital and analog data communication systems with the help of functional block diagrams. Define transmission impairments. [5+3]
2. Define causality and stability properties of systems. What are energy and power signals. Explain with example. [3+5]
3. Define LTI system. Find the convolution between $x(t) = e^{-at}u(t)$, ($a > 0$) and $h(t) = u(t)$ [3+5]
4. Define bandwidth, throughput, latency, jitter and bit error rate. Differentiate between coaxial cable and optical fiber. [5+3]
5. Differentiate AM and FM based on modulation index and bandwidth. An audio frequency signal $20\sin 2\pi \cdot 500t$ is used for AM with a carrier of $60\sin 2\pi \cdot 10^6t$. Calculate: (a) modulation index (b) Sideband frequencies, (c) Bandwidth requirements, (d) Total power delivered with a load of 75 Ohm. [4+4]
6. Explain polar, unipolar, bipolar and Manchester coding with example. Encode the bit stream 101000111011 using all coding mentioned above. [6+4]
7. What is block code? Design the code word of a (6,3) block code with any suitable generation matrix. [2+6]
8. Describe FDMA with example. Explain the digital hierarchy of T-carriers. [5+2]
9. Write short notes on: [3×5]
 - a) Spread spectrum
 - b) Packet switching
 - c) Cyclic codes

BCT III II

Exam.	Back (2066 & Later Batch)		
Level	BE	Full Marks	80
Programme	ECT	Pass Marks	32
Year / Part	III / I	Time	3 hrs.

Subject: - Data Communication (CT602)

- ✓ Candidates are required to give their answers in their own words as far as practicable.
- ✓ Attempt All questions.
- ✓ The figures in the margin indicate Full Marks.
- ✓ Assume suitable data if necessary.

1. Define data representation. How can data be represented? Compare and contrast analog communication system with digital communication system with appropriate block diagram. [2+6]
2. Define deterministic and random signal with example. Check whether the given system is linear and time invariant or not. [2+6]
 - i) $y(t) = \log(x(t))$
 - ii) $y(t) = tx(t)$
3. a) Find the Fourier series representation of the full-wave rectified Sine wave given below. [5]

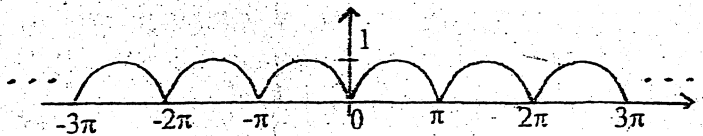

- b) Determine the Fourier transform of the following signal, $x(t)$. [5]

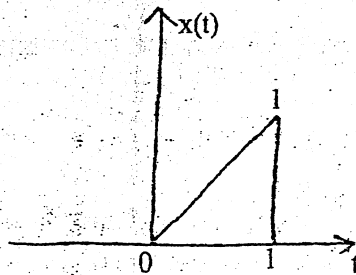

4. a) Briefly describe about transmission characteristics (frequency range, attenuation, delay and repeater spacing) of twisted pair cable, coaxial cable and optical fiber. [4]
- b) Describe about the factors that determine the performance of a channel? [4]
5. a) What is line coding? What are the desired properties of a line code? Encode the bit stream 01001100011 using the following encoding schemes: Unipolar NRZ-L, Unipolar NRZ-I, Unipolar RZ, Polar NRZ-L, polar NRZ-I, polar RZ, Manchester, and Alternate Mark Inversion (AMI) [3+8]
- b) Differentiate between PAM and PWM. [5]
6. a) Define multiplexing with example. Compare synchronous and asynchronous TDM. [2+4]
- b) Explain how DSSS (Direct Sequence Spread Spectrum) achieves bandwidth spreading. [4]
7. Differentiate between circuit switching and packet switching? Elaborate X.25 switching. [2+3]
8. a) What is the physical meaning of entropy and mention its equation. What is the condition for maximum and minimum entropy? Suppose there are 9 balls in a bin. Out of the 9 balls, 4 balls are red, 2 balls are yellow and 3 balls are green. Calculate the entropy of the system each time a ball is picked from the bin. [2+2]
- b) What is the minimum Hamming distance? Differentiate between dataword and codeword. We need a dataword of at least 11 bits. Find the values of (k) and (n) in the Hamming code $C(n,k)$ with $d_{min} = 3$. [2+4]
- c) What are cyclic codes? Differentiate between linear block codes and convolutional codes. [2+3]

Level	BE	Full Marks	80
Programme	BCT	Pass Marks	32
Year / Part	III / I	Time	3 hrs.

Subject: - Data Communication (CT602)

- ✓ Candidates are required to give their answers in their own words as far as practicable.
 ✓ Attempt All questions.
 ✓ The figures in the margin indicate Full Marks.
 ✓ Assume suitable data if necessary.

1. What are the advantages of digital communication system over analog communication system? Explain digital communication system with the help of block diagram. [2+6]
2. Define energy and power signals with appropriate mathematical expressions. Determine whether the following discrete-time (DT) signal is an energy or power signal. Also find its corresponding energy or power. $x[k] = \begin{cases} \cos\left(\frac{3\pi k}{16}\right), & -10 \leq k \leq 0 \\ 0, & \text{otherwise} \end{cases}$ [2+6]
3. a) Sketch output of Linear Time invariant system having impulse response $h(t) = e^{-at} u(t)$, for $a > 0$ and input signal $x(t) = u(t) - u(t-2)$. [5]
 b) Find the Fourier Transform of continuous time signal $x(t) = e^{-a|t|}$, for $a > 0$ [5]
4. a) What is guided transmission media? What are the advantages of optical fibers over coaxial cables and twisted pair cables? [1+3]
 b) State Nyquist's and Shannon's channel capacity formula. The spectrum of a channel is in between 3 MHz and 4 MHz. The SNR = 24 dB. Calculate the bandwidth, the maximum channel capacity using Shannon's formula. Then based on Nyquist's formula, find the number of signal levels required to reach the maximum channel capacity. [2+2]
5. What are the benefits of modulation? Explain ASK, FSK and PSK with mathematical expression, example and generation circuit. Encode the bit stream 1001101110 using unipolar, polar (NRZ-I, NRZ-L, RZ, Manchester), bipolar (AMI) encoding techniques. [3+7+6]
6. a) How can the use of spread spectrum technique provide security against jamming and interception? List the advantages and disadvantages of spread spectrum. [3+2]
 b) What is FDM? Assume a voice channel occupies a bandwidth of 4 kHz. We need to multiplex 10 voice channels with guard bands of 500 Hz using FDM. Calculate the required bandwidth. [2+3]
7. What is switching? Differentiate between datagram switching and virtual circuit switching. [2+3]
8. a) What do you mean by entropy? The five symbols from a source and their probabilities are shown in table below. By using the Huffman algorithm, find the source code for these symbols and determine the average code-word length and the entropy of the source. [1+8]

Symbol	Probabilities
A	0.4
B	0.3
C	0.15
D	0.1
E	0.05

- b) Where are the convolution codes used? Describe different types of convolution codes. [2+4]

Exam.	Regular		
Level	BE	Full Marks	80
Programme	BCT	Pass Marks	32
Year / Part	III / I	Time	3 hrs.

Subject: - Data Communication (CT 602)

- ✓ Candidates are required to give their answers in their own words as far as practicable.
- ✓ Attempt All questions.
- ✓ The figures in the margin indicate Full Marks.
- ✓ Assume suitable data if necessary.

1. Compare digital communication with analog communication system and explain digital communication system with the help of functional block diagram. [8]
2. Distinguish between energy and power signals. Define invertibility of a system. Which properties (Linearity, Causality, Time invariance, Stability and Memory) processes by the following system(i) $y[n] = 3x[n] - 4x[n-1]$ (ii) $y(t) = \sin(2\pi x(t))$. [2+6]
3. Define unit impulse function. What is its significance in signal analysis? Compute the Fourier series coefficients for the signal given below. [2+2+6]

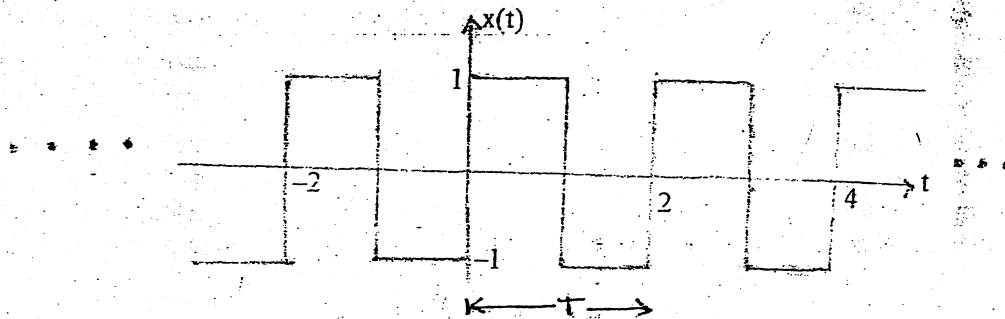

4. Describe the characteristics and performance of UTP cables over other guided transmission media. [4]
5. State and explain Shannon's channel capacity theorem. [4]
6. What is a modulation? Why is it required? Briefly explain the steps involved in encoding analog data as digital signal. Encode the following bit stream using unipolar (NRZ), polar (NRZ-L, NRZ-I, RZ, Manchester); bipolar(AMI) 10110001110. [4+6+6]
7. What is multiplexing? Explain its application. [4]
8. Compare FDM, WDM and TDM. What are the advantages and disadvantages of CDMA technique? [4+2]
9. What is switching? Differentiate between circuit and packet switching. [5]
10. Define information and Entropy. The probability of the five possible outcomes of an experiment are given as: $P(x_1) = 1/2$, $P(x_2) = 1/4$, $P(x_3) = 1/8$, $P(x_4) = P(x_5) = 1/16$. Determine the entropy and information rate if there are 16 outcomes per second. [4+6]
11. Define Hamming Distance and minimum Hamming distance. Suppose a code has a Hamming distance $d_{min} = 4$. What is the error detection and correction capability of this scheme? [2+3]

TRIBHUVAN UNIVERSITY
INSTITUTE OF ENGINEERING
Examination Control Division
2079 Bhadra

Exam.	Regular		
Level	BE	Full Marks	80
Programme	BCT	Pass Marks	32
Year / Part	III / I	Time	3 hrs.

Subject: - Software Engineering (CT 601)

- ✓ Candidates are required to give their answers in their own words as far as practicable.
- ✓ Attempt **All** questions.
- ✓ The figures in the margin indicate **Full Marks**.
- ✓ Assume suitable data if necessary.

1. What was the software crisis in the history of software engineering? Discuss the advantages and disadvantages of waterfall model of software development. [3+4]
2. Distinguish between user and system requirements. Why does an engineer ensure that functional and non-functional needs are in a requirement specification document? [2+4]
3. What is the importance of SRS document in Software development? Identify and document functional as well as non functional requirements for "issuing book from library". [2+5]
4. Draw level 0 and level 1 DFD's for an online shopping system. [3+5]
5. What are the different modular decomposition styles used during system design? What is repository model in software architecture? Explain its advantages and disadvantages. [4+3+2]
6. Define periodic and aperiodic stimuli in real time system. What are the different tasks to be performed in real time design process? [1+4]
7. Discuss about the advantages and disadvantages of software reuse. What is COTS integration? [5+1]
8. What are software components? Explain with examples their interfaces. [3+3]
9. What is software inspection? Explain. Distinguish between verification and validation. [5+2]
10. What distinguishes black box testing from white box testing? Are both necessary for software testing, or is just one sufficient? Justify with a few suitable examples. [5+3]
11. What is Software Quality Assurance (SQA)? Discuss all the levels of CMMI. [2+5]
12. Define Version, Variants and Release with respect to configuration management. [4]

TRIBHUVAN UNIVERSITY
INSTITUTE OF ENGINEERING
Examination Control Division
2079 Baishakh

Exam.	Back		
Level	BE	Full Marks	80
Programme	BCT	Pass Marks	32
Year / Part	III / I	Time	3 hrs.

Subject: - Software Engineering (CT 601)

- ✓ Candidates are required to give their answers in their own words as far as practicable.
- ✓ Attempt **All** questions.
- ✓ The figures in the margin indicate **Full Marks**.
- ✓ Assume suitable data if necessary.

1. What are typical software characteristics? Discuss spiral model of software development in brief. [3+5]
2. Prepare a list of functional requirements, level -0 and level -1 DFD for the following project:
An automated ticket issuing system sells bus tickets. When the user presses the button, a menu is displayed with potential destination along with a message to the user to select a destination. Once a destination is selected, users are requested to input their credit card. Its validity is checked and the user is then requested to input their personal information. When the credit transaction has been validated, the ticket is issued. [3+2+3]
3. What is the purpose of use case diagrams? Construct use case diagrams and context level diagram for a library management system. [2+4+2]
4. Differentiate between thin client and thick client model. Describe layered architecture for software. [3+5]
5. Define real-time operating system. List out some important characteristics of RTOS. [1+3]
6. What are the pros and cons of software reuse? What factors need to be taken care while software reuse planning? [5+2]
7. What are the components and component-based software engineering? What are the advantages and disadvantages of using components? [2+3]
8. Explain software inspections and formal methods. Explain the V-model for test-based software development. [4+6]
9. What is the purpose of using different COCOMO models? Explain the COCOMO model in cost estimation of the software. [2+4]
10. Differentiate between ISO and CMMI standards for software quality. What are formal technical reviews? Discuss all the levels of CMMI. [3+5+2]
11. What is software configuration management and why is it important? How could you do change management systematically in software projects? [2+4]

TRIBHUVAN UNIVERSITY
INSTITUTE OF ENGINEERING
Examination Control Division
2078 Bhadra

Exam.	Regular		
Level	BE	Full Marks	80
Programme	BCT	Pass Marks	32
Year / Part	III / I	Time	3 hrs.

Subject: - Software Engineering (CT 601)

- ✓ Candidates are required to give their answers in their own words as far as practicable.
 - ✓ Attempt All questions.
 - ✓ The figures in the margin indicate Full Marks.
 - ✓ Assume suitable data if necessary.
1. Define software. List the typical software characteristics? Justify this statement “software doesn’t wear out”. [1+3+4]
 2. What do you mean by software requirements document? Explain requirement engineering process in detail. [2+6]
 3. Draw use case diagram for a system illustrating the interactions between a doctor, who sees patients and prescribes him medicine and treatments. List some functional and non-functional requirements in this case. [5+3]
 4. What is software architecture? Why architecture is important to drive software development? Explain multi-tier architecture with example. [2+2+4]
 5. Distinguish between a real time and non-real time system. What is a data acquisition system? [2+2]
 6. List the different levels in which software reuse may be possible. What are the advantages and disadvantages of software reuse? [3+4]
 7. What are the benefits of CBSE? What are software components? Explain with symbols for components. [2+3]
 8. Differentiate between verification and validation. Explain how and why the V-model emphasis software V and V. Discuss various hierarchical level of testing. [2+4+4]
 9. What is COCOMO? What are the different types of COCOMO models proposed? What is the problem with using lines of code? [1+3+2]
 10. Explain formal technical review process. Explain how CMMI model is used to evaluate the maturity of a software development. [5+5]
 11. What is the difference between version and variant of a system? Describe change management process in software engineering. [2+4]

TRIBHUVAN UNIVERSITY
INSTITUTE OF ENGINEERING
Examination Control Division
2078 Kartik

Exam.	Back		
Level	BE	Full Marks	80
Programme	BCT	Pass Marks	32
Year / Part	III / I	Time	3 hrs.

Subject: - Software Engineering (CT 601)

- ✓ Candidates are required to give their answers in their own words as far as practicable.
- ✓ Attempt **All** questions.
- ✓ The figures in the margin indicate **Full Marks**.
- ✓ Assume suitable data if necessary.

1. What is software crisis? Briefly explain the qualities of a good software. [3+4]
2. What is a software process model? Explain how both the waterfall model and prototyping model of software process can be accommodated in spiral process model? [2+6]
3. A restaurant uses an information system that takes customer orders, sends the order to the kitchen, monitors the goods sold and inventory and generates reports for management.
 - a) List functional and non-functional requirements for this system. [5]
 - b) Develop DFD level 0 and level 1 for above scenario. [3+5]
4. What do you understand by control styles in architectural design? Explain call reference architecture with suitable example. [2+4]
5. Differentiate real-time software and other software. Explain data acquisition system. [2+3]
6. What are the benefits and problems of software reuse? What factors need to be taken care for software reuse planning? [3+4]
7. Compare validation and verification. Explain software inspection process. Explain unit test, integration test and system test. [4+4+3]
8. Define regression testing. Explain cyclomatic complexity as a software metric. [2+3]
9. What is software reliability and how can we measure it? Briefly explain CMM and its different levels. [4+5]
10. Write short notes on: [3×3]
 - a) CBSE (Component Based software Engineering)
 - b) Version and Release Management
 - c) COTS reuse

TRIBHUVAN UNIVERSITY
INSTITUTE OF ENGINEERING
Examination Control Division
2076 Chaitra

Exam.	Regular		
Level	BE	Full Marks	80
Programme	BCT	Pass Marks	32
Year / Part	III / I	Time	3 hrs.

Subject: - Software Engineering (CT 601)

- ✓ Candidates are required to give their answers in their own words as far as practicable.
- ✓ Attempt All questions.
- ✓ The figures in the margin indicate Full Marks.
- ✓ Assume suitable data if necessary.

1. What is software crisis? What are typical software characteristics? [4+3]
2. Explain the Prototyping model of software development. What are its advantages and disadvantages? [5+2]
3. Study the narration for a ride sharing system and prepare analysis and design models as specified below:

Real-time ridesharing is a service that arranges one-time shared rides on very short notice. Vehicle owners register to the system as Service Provider and customers register as Service Seeker. The vehicle registration can be done for motorbike and car only. This type of service makes use following technological advances:

 - GPS navigation devices to determine a driver's route and arrange the shared ride
 - Smartphones for a traveler to request a ride from wherever they happen to be

These elements are coordinated through a mobile application, which can instantaneously handle the driver payments and match using an optimization algorithm. When a seeker needs ride, he/she opens the mobile app which automatically tracks his/her location and marks as pick-up point. Seeker sets the drop-off point using map. Seeker can also search the location and set his/her drop-off point. The system calculates the estimated fare and seeker needs to confirm the ride. System searches the near by service providers and displays the information about the provider including the vehicle number and mobile number. Once the service provider picks the seeker, system tracks the route followed and calculates the fare once they reach to the drop-off point. Seeker may pay in cash or other electronic platform like e-sewa. Seeker can provide the feedback about his/her ride and can also view the ride history.

 - a) List functional and non-functional requirements for the system. [5]
 - b) Draw Level 0 DFD. [3]
 - c) Draw Level 1 DFD. [5]
4. Describe software architecture. Explain Client-Server architecture and its importance. [3+4]
5. What is the role of data acquisition system? Explain the difference between hard and soft real time system. [2+3]
6. What are the main problems with software reuse? List key factors that should be considered for reusing software components. [3+3]
7. Differentiate between verification and validation. What are the types of the faults that can be uncovered by software inspection? Differentiate between black-box testing and white-box testing. [3+2+5]
8. What is component composition? Briefly explain the use of COCOMO model. [2+3]
9. Explain different levels of CMMI. [5]
10. What is FTR? How is Formal Technical Review (FTR) performed? [2+5]
11. Write short notes on: [4×2]
 - a) Modular decomposition styles

TRIBHUVAN UNIVERSITY
INSTITUTE OF ENGINEERING
Examination Control Division
2076 Ashwin

Exam.	Back		
Level	BE	Full Marks	80
Programme	BCT	Pass Marks	32
Year / Part	III / I	Time	3 hrs.

Subject: - Software Engineering (CT 601)

- ✓ Candidates are required to give their answers in their own words as far as practicable.
- ✓ Attempt All questions.
- ✓ The figures in the margin indicate Full Marks.
- ✓ Assume suitable data if necessary.

1. What do you mean by requirement elicitation and analysis? List the characteristics, advantages and disadvantages of Incremental Development Model. [4+6]
2. In a particular college, a sports week needs to be organized you have been assigned a role of business analyst to design a DFD diagram for the whole system. Assuming the activities such as online registration, student council, form fill up, sport event venue and time, score card, rules and regulations, card system and prize distribution. [3+5+2]
 - a) Prepare the list of process and agents.
 - b) Draw the DFD up to level 1.
 - c) Distinguish between functional and non-functional requirements.
3. Why is architectural design really important? What are the different types of control styles used by software engineers in designing the architectures? Explain in detail. [2+6]
4. Differentiate between hard real time system and soft real time system. Outline real time system design process. [2+3]
5. Justify the statement "Advantages of reuse are lower costs, faster software development and lower risks." What is a design pattern? [3+2]
6. What is a component? Explain the component based software engineering (CBSE) process in brief. [2+4]
7. Differentiate verification and validation. Write different types of fault that can be determined from inspection. [5]
8. Explain the V-model for software development process. Distinguish between alpha and beta testing. [5+2]
9. Explain the cocomo model for software cost estimation. [5]
10. a) Define SQA. What are the main objectives of Formal Technical Reviews? [2+3]
 - b) Define term software reliability. Explain how CMM encourages continuous improvement of software process. [2+4]
11. Write short notes on: [4×2]
 - a) SEI Capability Maturity Model
 - b) Software version, variant and release

TRIBHUVAN UNIVERSITY
INSTITUTE OF ENGINEERING
Examination Control Division
2075 Chaitra

Exam.	Regular / Back		
	Level	BE	Full Marks
Programme	BCT	Pass Marks	32
Year / Part	III / I	Time	3 hrs.

Subject: - Software Engineering (CT 601)

- ✓ Candidates are required to give their answers in their own words as far as practicable.
- ✓ Attempt All questions. .
- ✓ The figures in the margin indicate Full Marks.
- ✓ Assume suitable data if necessary.

1. a) Define software crisis. How can you say that there was software crisis in late 60s? [5]
b) Explain incremental model. Write its advantages and disadvantages. [4+3]
2. DFD level-0 and DFD level-1 for the case study given below. [3+5]
A travel agency wants an Airline Ticketing System to be developed for the office so that user can easily book flight tickets from anywhere. First of all, the customer enters the destination and data for the flight. After that, the system displays the available airlines for the same along with route or available time which is provided by the airlines company. Now the customer selects the airline which he/she finds appropriate where he/she can either book the ticket or confirm the ticket. The customer pays the ticket charge either via e-sewa or transferring the amount to the agency's bank account directly. The customer has to provide the valid email address to get the notification of booking or ticket confirmation.
3. a) What is software design architecture and what is its significance in software engineering? [2+3]
b) What are the common modular decomposition styles used in architectural design? Explain. [5]
4. How is a real-time software different from other software? What is a data acquisition system? [2+3]
5. Briefly describe advantages and disadvantages of software reuse. What is COTS reuse? [4+2]
6. What are the different factors to be considered before reusing software components. Explain. [5]
7. What is verification and validation? Explain their difference. Why is verification and validation planning necessary in software engineering? [3+2]
8. Write about stub and driver testing. Differentiate between white box and black box testing. [3+3]
9. Describe Cyclomatic Complexity as a software testing metrics. Use the concept of Halstead's metrics to compute the program length, program vocabulary, program volume, potential volume, program level, programming effort and time for the following code. [2+4]

```

Int x, y, z;
z = 0;
while ( x > 0 )
{
    z = z + y;
    x = x - 1;
}
printf("%d",z);

```
10. a) What do you mean by Formal Technical Review (FTR)? How is a formal technical review conducted? [2+4]
b) Describe software reliability and SQA. [3+3]
11. Describe configuration management planning. [5]

Exam.	Back		
Level	BE	Full Marks	80
Programme	BCT	Pass Marks	32
Year / Part	III / I	Time	3 hrs.

Subject: - Software Engineering (CT601)

- ✓ Candidates are required to give their answers in their own words as far as practicable.
- ✓ Attempt All questions.
- ✓ The figures in the margin indicate Full Marks.
- ✓ Assume suitable data if necessary.

1. What factors have contributed to the making of the present software crisis? Suggest the possible solutions to the present software crisis? [3+3]
2. Why it is so difficult to gain a clear understanding of what the customer wants? Describe the guidelines for the requirement elicitation process with suitable examples. [3+4]
3. Suppose a travel and tour agency needs a software for automating its book keeping activities. The set of activities to be automated are rather simple and are at present being carried out manually. The travel agency had indicated that it is unsure about the type of user interface which would be suitable for its employees and its customers. Would it be proper for a development team to use the spiral model for developing this software? Justify. [6]
4. A company needs to develop a time Management system (TMS) for its executives. The software should let the executives register their daily appointment schedules. The information to be stored includes person (s) with whom meeting is arranged, venue, the time and duration of the meeting, and the purpose. When a meeting involving many executives needs to be organised, the system should automatically find a common slot in the diaries of the concerned executives, and arrange a meeting at that time. It should also inform the concerned executives about the scheduled meeting through e-mail. If no common slot is available, TMS should help the secretary to rearrange the appointments of the executives in consultation with the concerned executives for making room for a common slot. To help the executives check their schedules for a particular day the system should have a very easy-to-use graphical interface. Since the executives and the secretaries have their own desktop computers, the time management software should be able to serve several remote requests simultaneously. Many of the executives are relative novices in computer usage. Everyday morning the time management software should e-mail every executive his appointments for the day. Besides registering their appointments and meetings, the executives might mark periods for which they plan to be on leave. Also, executives might plan out the important jobs they need to do on any day at different hours and post it in their daily list of engagements. Other features to be supported by the TMS are the following—TMS should be able to provide several types of statistics such as which executive spent how much time on meetings. For which project how many meetings were organised for what duration and how many man-hours were devoted to it. Also, it should be able to display for any given period of time the fraction of time that on the average each executive spent on meetings.
 - a) List out all functional and non-functional requirements of the Time Management System. [6]
 - b) Draw a labelled DFD for the following Time Management Software (TMS). Clearly show the context diagram and its hierarchical decompositions up to level 2. [6]

5. Why is it necessary to design the system architecture before specifications are written? Explain the different methods of modular decompositions with suitable examples. [3+4]
6. What are the major technical and non-technical factors that hinder software reuse? Do you suggest to reuse much software and, if not, why not? [4+3]
7. Develop a complete test strategy for the Time Management System (Q.N.4). Document it in a Test Specification. [4+4]
8. What are the importance of quality management in Software Development? Explain about staged CMMI Model. [3+4]
9. What is COCOMO? Calculate COCOMO effort, development time in calendar month, average staffing and productivity for the software construction process of Q.N.4. State your assumptions if necessary. [2+6]
[4×3]
10. Write short notes on:
 - a) Real Time Operating System Vs. Non-real Time Operating System
 - b) Verification Vs. Validation
 - c) CBSE Process
 - d) Formal Technical Review

Exam.	Regular		
Level	BE	Full Marks	80
Programme	BCT	Pass Marks	32
Year / Part	III / I	Time	3 hrs.

Subject: - Software Engineering (CT601)

- ✓ Candidates are required to give their answers in their own words as far as practicable.
- ✓ Attempt **All** questions.
- ✓ The figures in the margin indicate **Full Marks**.
- ✓ Assume suitable data if necessary.

1. a) "Walking on water and developing software from specification are easy if both are frozen". Justify this statement. [5]
- b) Assume that you are the technical manager of software development organization. A client approached for a software solution. The problem stated by client have uncertainties which lead to loss if not planned and solved. Which model do you suggest for his project? Justify. Explain that model with its pros and cons. [5]
2. a) What is requirement engineering? Explain its steps. [4]
- b) For better healthcare facilities in remote areas, Ministry of Health (MOH) launches Telemedicine project. Through this project expert doctor from central hospital can examine patient in remote places through video conferencing. MOH propose to maintain central server to hold all patient records and medical history. Also system should able to manage routine of doctors, appointments and follow ups. Assume that you are technical lead of this project, answer the following questions.
 - (i) list out all functional and non-functional requirement of the systems [6]
 - (ii) Make project Feasibility Report [6]
3. A customer presents a cheque to a clerk. The clerk checks a database containing all account numbers and make sure whether the account number in the cheque is valid, whether adequate balance is there in the account to pay the cheque and whether the signature is authentic. Having done these the clerk gives the customer a token. The clerk also debits the customer account by an amount specified on the cheque. If the cash cannot be paid due to an error on the cheque, the cheque is returned. The token number is returned on the top of the cheque and it is passed on to the cashier. The cashier calls out the token number and the customer go to cash counter with the token. The cashier checks the token number, takes customer signature, pays cash, enter cash paid in a database called daybook and files the cheque. [8]
- Prepare physical and logical DFD. [8]
4. What are software quality measures? Explain in details about staged CMMI model. [2+6]
5. a) Discuss the differences between verification and validation. [4]
- b) Compare and Contrast [4]
 - (i) Unit testing and Integration testing
 - (ii) Alpha testing and beta testing

6. a) An application has following: 10 low external inputs, 8 high external outputs, 13 logical files, 17 interface files, 11 average external inquires and complexity adjustment factor of 1.10. What are the unadjusted and adjusted function point counts? [5]
- b) Explain component-based software engineering (CBSE) process. [5]
7. What is COCOMO? Using standard method, estimate cost of software construction process of Q.N.3. State your assumption clearly before calculating the cost estimate. [8]
8. Write short notes on followings: [3×4]
- a) Distributed Object architecture
 - b) Modular decomposition
 - c) Hard and soft real time system
 - d) Formal Technical Review and Inspection for QC

Exam.	Regular		
Level	BE	Full Marks	80
Programme	BCT	Pass Marks	32
Year / Part	III / I	Time	3 hrs.

Subject: - Software Engineering (CT601)

- ✓ Candidates are required to give their answers in their own words as far as practicable.
- ✓ Attempt **All** questions.
- ✓ The figures in the margin indicate **Full Marks**.
- ✓ Assume suitable data if necessary.

1. Supermandu Maha Nagarpalika is planning to introduce public transportation system with GPS based online vehicle tracking and smart card based payment system. Imagine, you are one of the software engineer working on that project. With clear statement of your assumptions on the system environment and specifications about the system, prepare the followings:
 - i) The project Feasibility report [6]
 - ii) Complete process models including context and two DFDs of level 2. [2+2+2]
2. What are the characteristics of good software? Explain waterfall model for software development. Also justify why this model is not suitable when we need to deliver important functionalities of software in short time period. [2+2+2]
3. a) "Component based software engineering is a reuse-based approach to defining and implementing loosely coupled components into system." Justify the statement. [4]
b) Explain why it may be necessary to design the system architecture before specification are written? Explain in detail about distributed object architecture with suitable example? [3+3]
4. How do CMM standard differ from that of ISO standards? Explain in detail about all the levels in CMM? [4+4]
5. a) What are the good and bad aspects of LOC and FP based estimation models? [5]
b) What makes the client fat or thin? Explain from model perspective. [5]
6. Explain alpha testing and beta testing of your software product? Prepare a checklist for software code inspection. [6+4]
7. Write short notes: [3×4]
 - i) Adaptor components for components integration
 - ii) Software version, variant and release
 - iii) Requirements discovery through prototyping
 - iv) SQA plan
8. Compare the following: [3×4]
 - i) Baselines versus Codeline in configuration management
 - ii) Unit testing versus integration testing
 - iii) Inspection versus review in software quality management
 - iv) Real-time versus batch operating system

Exam.	New Back (2066 & Later Batch)		
Level	BE	Full Marks	80
Programme	BCT	Pass Marks	32
Year / Part	III / I	Time	3 hrs.

Subject: - Software Engineering (CT601)

- ✓ Candidates are required to give their answers in their own words as far as practicable.
- ✓ Attempt All questions.
- ✓ The figures in the margin indicate Full Marks.
- ✓ Assume suitable data if necessary.

1. What is software crisis and what is its reason? Describe evolutionary model, in brief, explaining how it reduces crisis problem. [8]
2. In a particular school, there are various departments. There are various instructors and are having direct employment from corresponding departments. Students are admitted to school and later they choose their subject study program offered through various departments. The instructors are assigned for particular subject teaching task. Each department has a HOD to coordinate to overall activities, including class and lab scheduling processes. Students have to seat in for semester end exams as a final evaluation process. Assessment with 'NQ' status students are NOT allowed for final exam. At least after 8 semesters of such final evaluations, students with clearance form department, including HOD approval, students become ready for graduation".
Now, answer the followings. [5+5+5]
 - i) Prepare the list of processes and agents
 - ii) Draw the DFD for graduation and associated processes
 - iii) Depict the relationship between instructor, HOD and Department
3. Differentiate between thin client model and thick client model. Describe multiprocessor architecture for software. [3+5]
4. a) Explain the role of real-time operating system. [6]
b) Justify the statement "Advantages of reuse are lower costs, faster software development and lower risks." [4]
5. Compare and contrast: (a) alpha and beta testing (b) black box and white box testing (c) unit and integration testing. [8]
6. Give a suitable definition of software quality and briefly describe the rationale for your definition. Explain with quality attributes for software. [2+3+3]
7. What is the difference between version and release? Explain why we need Software Configuration Management (SCM). [2+4]
8. "Validation examines the dynamic behavior of software system". Explain this with an example. [5]
9. Write short notes on: [4×3]
 - i) COCOMO
 - ii) Component based software engineering
 - iii) Non-functional requirements

Exam.	Regular		
Level	BE	Full Marks	80
Programme	BCT	Pass Marks	32
Year / Part	III / I	Time	3 hrs.

Subject: - Software Engineering (CT601)

- ✓ Candidates are required to give their answers in their own words as far as practicable.
- ✓ Attempt **All** questions.
- ✓ The figures in the margin indicate **Full Marks**.
- ✓ Assume suitable data if necessary.

1. What do you mean by prototype? What are the risks if the prototyping becomes uncontrolled? Explain RAD in brief. [1+3+3]
2. Briefly discuss all the activities to be carried out in problem definition and feasibility analysis. [6]
3. Draw TWO DFD diagrams for simple e-commerce site based order processing system. Assume all necessary and required specifications on your own and state them clearly first. [2+4+4]
4. Explain how is real time OS and software different from non-real time OS and software? [6]
5. In theory, formal verification could be automated if the original specification is stated completely and precisely. Why is this hard to achieve in practice? Explain. [8]
6. The CMM rates software companies according to how well they identify and manage their software processes onto the 5 different levels. Explain any three out of these five levels. What advantages are there for a company to move up to the top level? [8]
7. Lines of code (LOC) and function point counts (FPC) are two measures of the size of a system. Explain advantages and disadvantages of using these two metrics for measuring systems. [3+3]
8. Mention the situations in which the software reuse is recommended. What do you mean by design pattern? [4+2]
9. What are the reasons behind the modern tendency toward the use of Component based Software Engineering? [5]
10. What are the main objectives of configuration management and version control? What is code line and baseline inversion management? [3+3]
11. Compare the followings: [3×4]
 - i) Black-hole vs. miracle in DFD
 - ii) Consistency vs. completeness in requirements engineering
 - iii) Traceability vs. Adaptability in reviewing steps
 - iv) Alpha vs. Beta testing

Exam.	New Back (2066 & Later Batch)		
Level	BE	Full Marks	80
Programme	BCT	Pass Marks	32
Year / Part	III / I	Time	3 hrs.

Subject: - Software Engineering (CT601)

- ✓ Candidates are required to give their answers in their own words as far as practicable.
- ✓ Attempt All questions.
- ✓ The figures in the margin indicate Full Marks.
- ✓ Assume suitable data if necessary.

1. What are typical software characteristics? What do you mean by software crisis? Elaborate. [4+4]
2. What are the reasons for software runways? Explain how both the waterfall model of the software process and prototyping model can be accommodated in the spiral process model. [2+6]
3. What is a behavior model? How does it differentiate from data model of the same system? Explain with examples and model. [3+3+2]
4. How many levels are there in CMM? Explain in detail about all the levels. [2+5]
5. Why software quality standards are needed? What are the metrics for software project size estimation? Discuss cyclomatic complexity with suitable example. [2+3+3]
6. Compare and contrast Verification with Validation. What do you mean by critical systems? How does partitioning augments in V and V process? Explain with example. [4+2+2+2]
7. "Survival of the fittest" is valid to software industry in today's competitive market. Explain the statement in the context of issues modern software configuration management must address nowadays. [8]
8. Differentiate between functional testing and structural testing. A web enabled system with a robust back-end database estimated to be of about 200 KLOC when complete. Assuming the system will work in semidetached mode; calculate the effort required per month, the development time, average number of staff required and he productivity rate. Consider COCOMO-2 for reference. [5+3]
9. Compare the following: [3×5]
 - i) Client server vs Distributed object architecture
 - ii) Real time vs Non-real time operating system
 - iii) Walk through vs Inspection in testing process

Exam.	New Back (2066 & Later Batch)		
Level	BE	Full Marks	80
Programme	BCT	Pass Marks	32
Year / Part	III / I	Time	3 hrs.

Subject: ▸ Software Engineering (CT601)

- ✓ Candidates are required to give their answers in their own words as far as practicable.
- ✓ Attempt All questions.
- ✓ The figures in the margin indicate Full Marks.
- ✓ Assume suitable data if necessary.

1. Explain why the waterfall model of software development is not an accurate reflection of software development activities. Explain better alternative model. [10]
2. Give your view on requirement engineering and requirement specification. [10]
3. What is behavior modeling in systems analysis process? Illustrate with a sample model diagram of any web-based transaction portal system. [5]
4. Explain the versioning process in the context of configuration management with all the associated components. [5]
5. How the modular decomposition concept is practiced in system design processes? Illustrate with your own example of a second level DFD. [4+6]
6. What specific considerations are to be made while designing typical software to be operated in real-time environment? Explain. [5]
7. Prepare a brief notes on design pattern with statement of their benefits. [5]
8. What is verification planning? Why such planning is required? What are the different steps involved in it? Explain. [8]
9. What is exception and error testing in the context of system implementation? [5]
10. What is COCOMO? Illustrate the calculation with an appropriate example. [5]
11. Write Short notes on: (any three) [4×3]
 - a) Software testing metrics
 - b) CMM level
 - c) Statistical quality assurance
 - d) CBSE

Exam.	Regular		
Level	BE	Full Marks	80
Programme	BCT	Pass Marks	32
Year / Part	III / I	Time	3 hrs.

Subject: - Software Engineering (CT601)

- ✓ Candidates are required to give their answers in their own words as far as practicable.
- ✓ Attempt All questions.
- ✓ The figures in the margin indicate Full Marks.
- ✓ Assume suitable data if necessary.

1. Why it is so difficult to gain a clear understanding of what the customer wants? What are the guidelines for the requirement elicitation process? [4+4]
2. Explain details about current model of software process. Explain why the waterfall model of the software process is not an accurate reflection of software development activities. [4+4]
3. Read the case mentioned hereunder carefully and: [5+3]
 - a) Make DFD level 1 for the system
 - b) What do you mean by DFD balancing in the given case?

A customer visits an online movie portal. He chooses DVD movies from three different categories: Sci-Fi, Classical and Romantic and places the order for the same. He is supposed to be able to make online payment using his bank details. Upon successful transaction he is expected to receive confirmation through his e-mail.

4. Explain why it may be necessary to design the system architecture before specifications are written. Explain client-server architecture with appropriate example. [4+5]
5. How do real-time software and operating system differ from non-real time software and operating system? Describe Data Acquisition System. [4+4]
6. What are the benefits of CBSE? How closely code generation feature of case tools are associated with CBSE? Explain. [3+5]
7. How does the SEI CMM ensure quality aspects of any complex software under development? What are the differences between ISO and CMM? [4+3]
8. What is COCOMO? Calculate COCOMO effort, development time in calendar month, average staffing and productivity for project of application program that is estimated to be 49,200 lines of code. *embedded type* [3+5]
9. Establish the chronology among component, release unit and integration testing. Also write distinctive notes on their testing. [3+4]
10. Write short notes on: [3×3]
 - a) Software Requirement Specifications (SRS)
 - b) Generator based reuse
 - c) Change management

41 TRIBHUVAN UNIVERSITY
INSTITUTE OF ENGINEERING
Examination Control Division
2070 Chaitra

Exam.	Regular		
Level	BE	Full Marks	80
Programme	BCT	Pass Marks	32
Year / Part	III / I	Time	3 hrs.

Subject: - Software Engineering (CT601)

- ✓ Candidates are required to give their answers in their own words as far as practicable.
- ✓ Attempt All questions.
- ✓ The figures in the margin indicate Full Marks.
- ✓ Assume suitable data if necessary.

1. What are the different processes for requirements gathering? Explain at least three different methods and also prepare a comparative chart of with their pros and cons of each. [3+4.5+2.5]
2. What are the major components of any feasibility study report? Explain with examples. The candidate matrix with recommendation in a feasibility report is considered as a standard, justify with reason. [7+3]
3. Explain in detail on CMMI levels. [10]
4. Explain why software reliability is important. Give two examples of worst case disaster due to software failure. [10]
5. Discuss the difference between verification and validation. What is the difference between alphas of beta testing? [10]
6. Write short notes on: (any four) [5×4]
 - a) Clean room engineering
 - b) Risk Analysis
 - c) Black box testing
 - d) Object oriented analysis
 - e) Software quality assurance
7. Describe different types of software maintenance. [10]

35 TRIBHUVAN UNIVERSITY
INSTITUTE OF ENGINEERING
Examination Control Division
2070 Chitra

Exam.	Old Back (2065 & Earlier Batch)		
Level	BE	Full Marks	80
Programme	BCT	Pass Marks	32
Year / Part	IV / I	Time	3 hrs.

Subject: - Software Engineering (EG742CT)

- ✓ Candidates are required to give their answers in their own words as far as practicable.
- ✓ Attempt **All** questions.
- ✓ The figures in the margin indicate **Full Marks**.
- ✓ Assume suitable data if necessary.

1. Define the following in terms of software engineering. (5x2)
 - a) Top-down approach
 - b) Software error and their impact
2. What are the main purposes of DFD and ER diagram? Explain with example. (10)
3. What is software maintenance? What are the types of software maintenance? Explain with example. (3+7)
4. How the CASE tools are classified? Discuss the importance and feature of CASE tools. (4+6)
5. What is a prototype model? Under what circumstances is it beneficial to construct a prototype model? (4+6)
6. Define SQA plan. Explain the software quality standards with example. (4+6)
7. Define the software reliability. Explain the software reliability models with example. (3+7)
8. What is user acceptance testing? Explain the different testing in user acceptance testing. Why is it necessary? (2+6+2)

Exam.	New Batch 2066 & Later Batches		
Level	BE	Full Marks	80
Programme	BCT	Pass Marks	32
Year / Part	III / I	Time	3 hrs.

Subject: - Software Engineering (CT601)

- ✓ Candidates are required to give their answers in their own words as far as practicable.
- ✓ Attempt All questions.
- ✓ The figures in the margin indicate Full Marks
- ✓ Assume suitable data if necessary.

1. What makes the software development process a complex? The simple man-month measurement and additional workers assignment for delayed project does not work in software project, why? Explain in detail. [7]
2. What are the different techniques used for requirements gathering and analysis? Explain any three methods in detail. [7]
3. If the principle jobs of Software Engineering are to write codes and programs then why do such engineering need CASE tools? What are the benefits of using CASE tools? [7]
4. In order to schedule the classes, a famous engineering school, Mero College of Engineering (MCE) in Dauramandu, needs to know about courses that can be offered, instructors and their availability, audio/visual equipment requirements for particular courses, and class rooms. From the list of courses, the courses that can be scheduled are selected in the scheduling process. For each of these courses, one or more classes are scheduled, which are called sections of the same class. The problem of schedulers is to assign classes to instructors, rooms and time slots. The schedulers are constrained by the reality that (a) some courses cannot conflict because many students take them during the same semester, (b) instructors cannot be in two places at the same time, (c) rooms cannot be double-booked. Construct a system level data model following the above details of class scheduling process with clear statement reasonable assumptions that you have made. [7]
5. The Capability Maturity Model (CMM) rates software companies according to how well they identify and manage their software processes. Present the list of five different levels of the model and explain any two in detail. What advantages are there for a company to move up to the top level? [7]
6. Why software verification is essential before launching any system? Write a brief note on verification. Differentiate between verification and validation. [5]
7. What is Equivalence partitioning? Explain with an example of checking for a campus student roll number entry like 674211, where 67 is year 2067, 4 is for Electronics engineering (there are 1-to-7 different engineering programs) and next 2 is the section id, which can range from 1-to-9 and last two digits are roll call that may range from 1-to-48. [5]
8. Why unit test is not enough in the system verification process for a complex system, which consists of multiple and interacting units. Write in brief, what other types of tests are required? [8]
9. Explain the various control style used in architectural design. [6]
10. Provided a brief comparison of the following: [3x4]
 - a) Multiprocessor architecture versus Client-Server architecture
 - b) Reuse Framework versus pattern Generator
 - c) DBMS versus data acquisition system
11. Write short notes on: [3x3]
 - a) Component Based Design
 - b) Software Quality Assurance plan
 - c) Release Management

Exam.	Regular		
Level	BE	Full Marks	80
Programme	BCT	Pass Marks	32
Year / Part	III / I	Time	3 hrs.

Subject: - Software Engineering (CT601)

Candidates are required to give their answers in their own words as far as practicable.

Attempt All questions.

The figures in the margin indicate Full Marks.

Assume suitable data if necessary. —

What is the purpose of going through feasibility study? List out the various types of feasibility to be studied and explain any two types in detail. [7]

Why the Software Requirement Specification (SRS) document is required during the system development phases? How could you justify the extra efforts and resources being used in this specification detailing at the early stage, which outweigh the resource and efforts required to meet the obscure specification later? [7]

Differentiate function and nonfunctional requirement used during requirement engineering process. [7]

Bhrantipur Book Store is popular among engineering students within the city of Bandhapur, as they have good reputation of making available of the reference books very efficiently through their books inventory system. Their reputation is mainly because of their close coordination with engineering schools. The various departments submit initial data about courses, instructors, textbooks and projected enrollments to the book store on a reference-book master list. The book store then generates a purchase order, which is sent to publishing companies that supplies the books. Book orders arrive at the bookstore accompanied by a packing slip, which is checked and verified by the receiving departments of engineering schools. When they pay for the books, the students are given sales receipt.

Following the details of the book order, inventory and sales processes prepare a system level process (behavior) model diagram for above scenario with clear statement of any assumptions that you have made. [7]

What are the different characteristics of the systems at the different levels of Capability Maturity Model Integration (CMMI)? Explain the two top levels of integration models and relate how well these models are effective in managing their software processes. [7]

What is the fundamental difference between a black-box test and white-box test? Explain with appropriate examples of software test. [5]

What is Equivalence Partitioning? Explain with an example of checking for a telephone number (of a Country called *Pumpkin Republic*, which has 85 districts altogether) entry like 4422561263, where first two digits signify the number of district, third digit for either STN (1) or Cellular (2) and remaining digits are just numbers. [5]

What is the fundamental difference between an alpha versus beta test? Explain about their importance in software development process. [8]

What is the role of reference architectures in the process of system design? Justify with sample. [6]

Provide a brief comparison of the followings: [3×4]

- Distributed Object versus Multiprocessor architecture
- Application Framework versus Component Reuse
- General OS versus Real-time OS

Write short notes on: [3×3]

- Software Quality Assurance
- Version control
- Version and Release management

Exam.	BE	Full Marks	80
Level	BCT	Pass Marks	32
Programme	III / I	Time	3 hrs.

Subject: - Software Engineering (CT 601)

- ✓ Candidates are required to give their answers in their own words as far as practicable.
- ✓ Attempt All questions.
- ✓ The figures in the margin indicate Full Marks.
- ✓ Assume suitable data if necessary.

1. What is software crisis? Explain with the help of an example. [5]
2. Describe Spiral model for software development. What are its advantages and disadvantages? [5]
3. A restaurant uses an information system that takes customer orders, sends the order to the kitchen, monitors the goods sold and inventory and generates reports for management. List functional and non-functional requirements for this Restaurant Information System. [5]
4. Explain requirement management process with necessary illustration. [5]
5. Why system modeling is important? Mention the weakness of structured analysis method? [2+3]
6. What is an architectural design? Why it is important in software engineering? Explain multiprocessor architecture with example. [2+3+5]
7. Define a real-time system. Explain the real-time operating system and its components? [1+4]
8. What are the benefits and problems of software reuse? What factors need to be taken care of for software reuse planning? [5]
9. Explain why program inspection are an effective technique for discovering errors in a program? What types of error are unlikely to be discovered through inspections? [5+5]
10. Consider a program for the determination of the nature of roots of a quadratic equation. Its input is a triple of positive integers (say a, b, c) and values may be from interval [0, 100]. The program output may have one of the following words. [Not a quadratic equation; Real roots, Imaginary roots, Equal roots]. Design test cases to test this program. [5]
11. How do you conduct formal technical review? Explain Garvin's quality dimensions. [6+4]
12. Write short notes on: (any four): [2.5×4]
 - a) Change Management
 - b) Version and Release Management
 - c) COCOMO
 - d) Component based Software Engineering
 - e) Feasibility Study

TRIBHUVAN UNIVERSITY
INSTITUTE OF ENGINEERING
Examination Control Division
2079 Bhadra

Exam.	Regular		
Level	BE	Full Marks	80
Programme	BEL, BEX, BCT	Pass Marks	32
Year / Part	III / I	Time	3 hrs.

Subject: - Instrumentation II (EX 602)

- ✓ Candidates are required to give their answers in their own words as far as practicable.
- ✓ Attempt **All** questions.
- ✓ The figures in the margin indicate **Full Marks**.
- ✓ Assume suitable data if necessary.

1. a) Define a microprocessor based instrumentation system. Differentiate between open loop and closed loop microprocessor based instrumentation. [1+4]
- b) Describe direct memory access. [3]
2. Design an interfacing circuit to set up bidirectional data communication in the master-slave format between two 8085A microcomputers. Use the 8255A as the interfacing between the master and the slave microcomputers. What will be the port addresses and control word. Write necessary program to transfer a block data from the master to the slave along with its flowchart diagram. [10]
3. a) Explain how communication takes place between PC (DB9 port) and printer (DB 25 port) using Null modem connection. [4]
- b) What are common USB packet field? Explain different USB packets. [3+3]
4. Interface a suitable DAC using 8255 PPI to an 8085 microprocessor to generate a square wave oscillating between 0V and 5V having a frequency of 1 KHz. Describe the interfacing circuit along with the necessary program. [8]
5. List the characteristics of Bluetooth. Explain the components of data logger with the help of block diagram. [2+6]
6. Describe any three mechanisms of noise coupling. Explain briefly on prevention of noise coupling. [3+3]
7. Write an importance of decoupling, ground bounce, cross talk and impedance matching in designing circuit. [6]
8. What are the different types of boards for electronics prototyping? List out each circuit boards characteristics. [2+4]
9. Explain about Embedded and Real Time Software used to run and control various modern instruments. As an instrumentation engineer, discuss the different approaches of coupling and cohesion technique to define tasks and design an integrated module. [6]
10. Case study is related to the basic measurement requirements, accuracy and specific hardware employed environmental conditions under which the instruments must operate, signal processing, transmission and output devices. Regarding your case study visit; draw a block diagram of the existing control system and mention the problems found in the existing system. You should also draw an interfacing diagram for solving the problem with discussing merits and demerits of your recommended system in terms of cost, manpower and plant automation. [12]

TRIBHUVAN UNIVERSITY
INSTITUTE OF ENGINEERING
Examination Control Division
2079 Baishakh

Exam.	Back		
	Level	BE	Full Marks
Programme	BEL, BEX, BCT	Pass Marks	32
Year / Part	III / I	Time	3 hrs.

Subject: - Instrumentation II (EX 602)

- ✓ Candidates are required to give their answers in their own words as far as practicable.
- ✓ Attempt All questions.
- ✓ The figures in the margin indicate Full Marks.
- ✓ Assume suitable data if necessary.

1. What are the basic features of MBI system? Compare open loop and closed loop microprocessor based system with suitable examples. [2+6]
2. 8255 is to be operated in mode O. Port A and port C upper are designed as output for LEDs and port B and port C lower as input ports for DIP switches. Address line A15 is connected with \bar{cs} of 8255 through an inverter.
 - a) Draw the complete mapping diagram. [2]
 - b) Determine the port addresses. [2]
 - c) Determine the control word. [1]
 - d) Write a program to read the DIP switches and display the reading from port B at port A and C lower at port C upper. [3]
3. a) Show the interfacing circuit of TTL logic with RS 232, appropriate line drivers and line receivers. [3]
- b) Describe the enumeration process in USB 2.0 appropriate flow diagrams. Compare and contrast between USB device and host interface chips and list three examples of each type. [4+3]
4. Consider yourself as a fluid dynamic engineer, who has been assigned the task of designing a hardware circuit that keeps a gas chamber under standard temperature and pressure (STP) conditions. The circuit should be an MBI system, an 8255 PPI, two 10-bit ADCs and appropriate temperature and pressure sensors that constantly monitor the pressure and temperature inside the gas chamber. An alarm LED should be lighted to notify the operator when either the temperature exceeds zero degree Celsius or the pressure exceeds hundred Kilopascals. Calibrate your temperature and pressure sensors accordingly. Sketch your design, show the necessary control words, and draw an appropriate flowchart to show the logic of your software algorithm. [8]
5. Describe the Bluetooth network topologies. Explain the characteristics and application of data logger. [4+4]
6. Define grounding and shielding. Explain inductive and capacitive shielding mechanisms. [2+4]
7. Explain the different types of transmission line issues that should be considered while designing the high speed circuit. [6]
8. a) Discuss the general process of creating a PCB with appropriate figures. [3]
- b) Why is routing signal traces important during circuit layout? Explain the factors that need to be considered while creating a signal trace. [1+2]
9. a) What do you mean by embedded and real time software? Discuss the software model suitable for your academic project. [4]
- b) What are good programming practices? Discuss the nature of bugs and preventive steps to minimize it. [4]

10. Suppose, the CEO of the company where you performed your case study is impressed with your case study report, and decides to hire you as a consulting engineer to oversee their existing MBI system. You are assigned the task of revamping their existing MBI system with the blueprint that you have designed. Show a well labeled, clear and detailed sketch of your design that you will be presenting to the board of directors to convince them to implement your idea. Your block diagram and supporting documents should include a minimum of the following items: the hardware solution, the software requirements, the advantages and disadvantages of your own strategy, the gain in efficiency of the plant after employing your plan, and a cost breakdown of realizing your project.

[12]

TRIBHUVAN UNIVERSITY
 INSTITUTE OF ENGINEERING
Examination Control Division
 2078 Bhadra

Exam.	Regular		
Level	BE	Full Marks	80
Programme	BEL, BEX, BCT	Pass Marks	32
Year / Part	III / I	Time	3 hrs.

Subject: - Instrumentation II (EX 602)

- ✓ Candidates are required to give their answers in their own words as far as practicable.
- ✓ Attempt All questions.
- ✓ The figures in the margin indicate Full Marks.
- ✓ Assume suitable data if necessary.

1. Define instrumentation system. Compare status check I/O, Interrupt driven I/O and DMA. [2+6]
2. Design an interfacing circuit to set up bidirectional data communication in the master-slave format between two 8085A microcomputers. Use the 8255A as the interfacing between the master and the slave microcomputers. What will be the port addresses and control word. Write necessary program to transfer a block of data from the master to the slave along with its flowchart diagram. [9]
3. a) Explain simplex, half duplex and full duplex operation of RS-232 serial standard. [4]
 b) Describe different types of USB protocols along with the common USB packet fields. [6]
4. Explain the principle involved while interfacing an 8-bit ADC using interrupt; including suitable block diagram, process flow diagram and necessary ALP subroutine. [8]
5. List the major characteristics of Bluetooth. Draw the block diagram of data acquisition system and explain each block. [3+5]
6. Explain the principle of energy coupling. Describe about capacitive coupling with remedies. [6]
7. Discuss and differentiate between different types of fault tolerance schemes used in the purpose of circuit design. [6]
8. Explain ground, returns and shields in the context of circuit layout. [6]
9. a) Draw the complete block diagram for prototype model in software development process and explain its component in brief. [4]
 b) Write about White box testing and Black box testing. [3]
10. Draw the complete block diagram of industrial process control system involved in your case study. Explain why you want to implement this control system over existing one in terms of cost, manpower and plant automation. What problems you might face after implementing this control system. [12]

TRIBHUVAN UNIVERSITY
INSTITUTE OF ENGINEERING
Examination Control Division
2078 Kartik

Exam.	Back		
	Level	BE	Full Marks
Programme	BEL, BEX, BCT	Pass Marks	32
Year / Part	III / I	Time	3 hrs.

Subject: - Instrumentation II (EX 602)

- ✓ Candidates are required to give their answers in their own words as far as practicable.
 - ✓ Attempt All questions.
 - ✓ The figures in the margin indicate Full Marks.
 - ✓ Assume suitable data if necessary.
1. a) What is the rationale behind using a microprocessor in instrumentation systems? Describe two situations where an open-loop MBI system performs better than a closed-loop MBI system, illustrating your answer with block diagrams. [1+3]
 - b) Describe the DMA active and idle cycles with appropriate figures. Provide at least five disadvantages of using DMA controllers. [2+2]
 2. Draw the circuit diagram to interface 8255A PPI with 8085 microprocessor at base address B0H. Write an assembly program that determines the addition of contents of port A and port B and display the result in port C. Use appropriate control word to initialize the 8255A. [3+5]
 3. a) Define bit rate and baud rate. Determine a character transmission rate using asynchronous serial data transfer method at baud rate 9600. Suppose a character has 7 bits data, one bit start bit, two bits stop bit and none parity. Calculate the time required to send a word: Engineer. [5]
 - b) Describe the problems occur when you try to connect RS-232 devices that both are configured as DTE. How this problem can be resolved? [5]
 4. What are the parameters to characterize ADCs? Design a circuit to interface ADC0808 with 8085 microprocessor using 8255A PPI. [2+6]
 5. a) Draw the block diagram of a digital transmission system that can be used to transmit analog as well as digital data. Compare and contrast analog and digital transmission techniques with at least five distinguishing characteristics. [2+2]
 - b) Design a data logging and storage system that is capable of receiving and storing signals from optical fibers, satellites and Bluetooth devices. Provide the block diagram of the overall system, which should show how messages get transmitted over the three transmission schemes and how the logger receives them. [4]
 6. How ground loop can be prevented? Explain the Electromagnetic coupling. [6]
 7. Explain ground bounce, decoupling and crosstalk in the context of circuit design. [6]
 8. What are the factors that need to be considered while routing the signal traces in circuit layout. How do you avoid crosstalk while making layout of the circuit? [2+4]
 9. What are the different phases of bugs in software development? Explain the different types of techniques used for software testing. [3+5]
 10. Draw the complete block diagram of industrial process control system involved in your case study. Explain why you want to implement your control system over existing one in terms of cost, manpower and plant automation? What problems you might face after implementing this control system? What are the benefits of new system over old one? [12]

Exam.	Regular		
Level	BE	Full Marks	80
Programme	BEL, BEX, BCT	Pass Marks	32
Year / Part	III / I	Time	3 hrs.

Subject: - Instrumentation II (EX 602)

- ✓ Candidates are required to give their answers in their own words as far as practicable.
- ✓ Attempt All questions.
- ✓ The figures in the margin indicate Full Marks.
- ✓ Assume suitable data if necessary.

1. a) Explain the basic modes of data transfer techniques available between microprocessor and peripheral devices. [5]
- b) Mention the features of Microprocessor Based Instrumentation system. [3]
2. Port A is to design as the input for a keyboard in interrupt driven I/O and Port B as the output for a printer in status check I/O using mode 1 of 8255 with 8085 microprocessor as shown below: [9]
 - a) Find port addresses by analyzing decoding logic.
 - b) Determine the control word to set up port A as input and port B as output.
 - c) Determine the BSR word to enable INTE_A.
 - d) Determine the masking byte to verify the OBF_B line.
 - e) Write main program and a read and write subroutines to accept characters from keyboard and to send them to print.

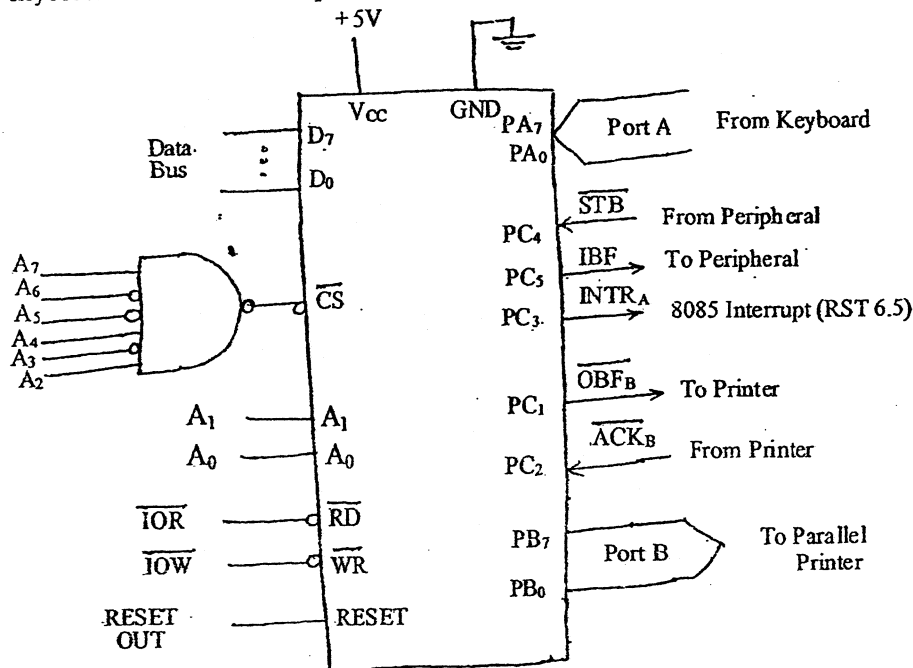

3. a) Explain the Null modem with and without handshaking mechanism. [5]
- b) Explain Cyclic Redundancy Code with suitable example. [4]

4. Design the interfacing of 1408 DAC with an output port of address AF H for 0v to 10v range. Note that take appropriate values for resistors and capacitors. [8]
5. a) How can you design the communication system with satellite as an unguided transmission scheme? [4]
b) Explain the Data Acquisition system with the help of compact data logger. [4]
6. Explain different types of filtering mechanisms used to reduce conductive noise coupling on the basis of frequency, mode and amplitude. [6]
7. Define ground bounce and crosstalk in circuit design. List their reduction ways. [6]
8. Describe the different terminologies used in routing signal traces for designing a commercial circuit layout. [6]
9. Explain spiral software development model with its advantages and disadvantages. Describe cohesion and coupling. [5+3]
10. Answer the following questions with regard to your case study. [12]
 - a) Describe the existing work flow mechanism of the industrial instrumentation system.
 - b) What are the critical factors affecting the production of existing system and what measures you can recommend for mitigating those factors?
 - c) Design a proposed system using microprocessor/ microcontroller, input/ output devices, interfacing process, communication protocols, data converters and handshake signals with neatly labeled block diagram.
 - d) List out the different advantages of the proposed plan in terms of technology, production rate, quality assurance, cost-benefit and return on investment (ROI).

Exam.	Back		
Level	BE	Full Marks	80
Programme	BEL, BEX, BCT	Pass Marks	32
Year / Part	III / I	Time	3 hrs.

Subject: - Instrumentation II (EX 602)

- ✓ Candidates are required to give their answers in their own words as far as practicable.
- ✓ Attempt All questions.
- ✓ The figures in the margin indicate Full Marks.
- ✓ Assume suitable data if necessary.

1. a) Explain microprocessor based instrumentation system with its block diagram. [5]
 b) List out the factors to be consider while selecting a processor. [3]
2. An 8255A PPI card is connected to 8085 microprocessor has system as shown in figure below in which control word is stored in address of F3H. [1+3+2+2+2]
 - a) What are the addresses captured by 8255A PPI card?
 - b) Draw the minimum interfacing circuit.
 - c) Write down the control word to initialize the 8255A PPI card.
 - d) Write down the status word format for 8255A PPI card for the system.
 - e) Write down BSR control word to initialize port A interrupt request.

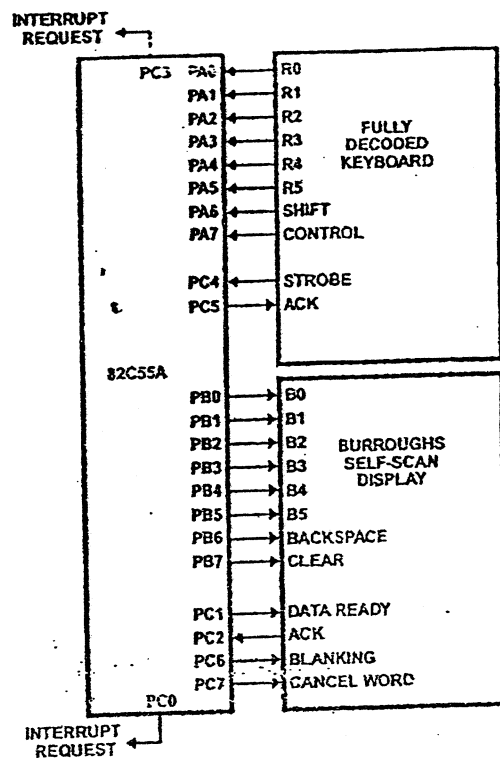

3. a) What is the importance of RS 232-C in serial communication? Explain the RS 232-C working principle with its different types of signals. [1+4]

- b) What is USB? Explain its common packet fields. [1+3]
4. a) Describe INL and DNL error of data converter with necessary illustrations. [4]
- b) With necessary diagram, Explain interfacing of 8 channel 8 bit ADC with 8085 microprocessor along with timing diagram. [5]
5. a) Discuss analog communication system and digital communication system with an appropriate block diagram. [4]
- b) Mention the characteristics of Bluetooth. Differentiate between piconet and scatternet network topology used in Bluetooth environment. [4]
6. a) What will happen to the electronic circuit connected in single point ground system when operated in frequency greater than 1 MHz? Explain with necessary illustration. [3]
- b) Explain how decoupling capacitor can be used to suppress the transient current. What effects do you observe when very large decoupling capacitor is connected in your circuit? [3+2]
7. a) What is reliability? List out the factor affecting reliability. [1+2]
- b) What are the factors that need to be considered while designing high speed circuit. [3]
8. How do you reduce crosstalk when routing signal traces on a PCB? [4]
9. Explain different types of software bugs that might exist in software. How these bugs can be identified while implementing different types of software testing. [6]
10. Explain existing industrial process control system involved in your case study with necessary block diagram. Recommend the changes that you deem necessary for the improvement of overall system performance. Explain why management should implement these changes. What are the probable problems you might face after implementation of your recommended system? [12]

TRIBHUVAN UNIVERSITY
 INSTITUTE OF ENGINEERING
Examination Control Division
 2075 Chaitra

Exam.	Regular / Back		
	Level	BE	Full Marks
Programme	BEL, BEX, BCT	Pass Marks	32
Year / Part	III / I	Time	3 hrs.

Subject: - Instrumentation II (EX 602)

- ✓ Candidates are required to give their answers in their own words as far as practicable.
- ✓ Attempt All questions.
- ✓ The figures in the margin indicate Full Marks.
- ✓ Assume suitable data if necessary.

1. a) Define closed loop MBI system with suitable example. [2]
 b) Among full or partial address decoding, which method of address decoding do you choose while interfacing memory device? Give reasons with suitable example. [4]
2. Interface a parallel bus centronics printer with 8085 microprocessor using 8255A in mode 1 output configuration.
 a) Draw the necessary interfacing circuit required for this purpose using 8255 PPI in handshake mode. [3]
 b) Determine port address as per your chip select logic. [2]
 c) Determine the control word required for printing operation. [2]
 d) Draw the timing waveform for transferring data to the printer. [2]
 e) Write an ALP to print characters whose ASCII code is available in memory location from 9000H. [3]
3. a) Explain the transferring of serial data using asynchronous transfer. One character is formed with 7-bit ASCII code, 1-bit start, 2-bit stop and 1-bit parity. [4]
 b) Describe up to date USB standards. Differentiate different USB data transfer mechanisms with suitable example of each. [6]
4. a) Explain the interfacing technique of 12-bit DAC to 8-bit Data bus. [6]
 b) Explain different types of errors in ADC & DAC. [4]
5. Explain Bluetooth network topology in detail. Why optical fiber has high demand in the field of communication. [4+2]
6. Explain different types of Energy coupling mechanisms with suitable example of each. How can a circuit be protected from ESD? [6]
7. What do you mean by reliability in a circuit design? Discuss how the reliability can be achieved by incorporating fault tolerance. [6]
8. a) What is PCB? Write down the advantages of PCB. [1+2]
 b) How do you reduce cross talk when routing signal traces on a PCB? [3]
9. Define roll back recovery with suitable example. Explain the spiral model software development cycle. [2+4]
10. Explain your industrial visit carried out on your case study in terms of existing system circumstances, problem identification and analysis, recommendation plan, requirement and feasibility analysis of the recommended plan and rollback plan if necessary. Also list out the different advantages of the proposed plan in terms of technology, production rate, quality assurance, cost-benefit and return on investment (ROI) for the particular industry. [12]

Exam.	Back		
Level	BE	Full Marks	80
Programme	BEL, BEX, BCT	Pass Marks	32
Year / Part	III / I	Time	3 hrs.

Subject: - Instrumentation II (EX602)

- ✓ Candidates are required to give their answers in their own words as far as practicable.
- ✓ Attempt All questions.
- ✓ The figures in the margin indicate Full Marks.
- ✓ Assume suitable data if necessary.

1. a) What do you mean by interfacing? A RAM chip of 512 bytes is given for interfacing with 8085 microprocessor system. Design an address decoding hardware for the same. [1+3]
 b) What is an interrupt driven data transfer? Explain the operation of interrupt driven data transfer with flowchart of interrupt subroutine and main programme sequence. [1+5]
2. A/D converter requires signal to start the conversion and indicates with the end of conversion signal. 8255A PPI is interfaced with 8085 microprocessors at 80H. Microprocessor reads 8-bits O/P data of the ADC at port A and display the same data to eight LED's connected at port B of 8255A. State any assumptions made.
 - a) Identify the address captured by the card [1]
 - b) Determine the necessary control words [2]
 - c) Draw the schematic interfacing circuit [2]
 - d) Write a program to perform the operation [3]
3. a) What is the importance of RS232-C in serial communication? Determine the time required to transmit a string: "Life is beautiful." using asynchronous serial data transfer method in baud rate of 4800 Baud. Suppose a character has 7 bits data, one bit start bit, one bit stop bit and one bit even parity bit. [2+4]
 b) Differentiate between USB 1.0 and USB 2.0. [1]
4. Interface a 10-bit DAC with 8255 PPI and 8085 CPU running at 2 MHz. Write an ALP to generate a triangular wave of frequency 500 Hz using the same interfacing circuit. The amplitude of the triangular wave should be +5V. [8]
5. a) 'In satellite communication the uplink frequency and downlink frequency are different.' Why? Explain the Bluetooth network topology. [1+3]
 b) Compare data archiving and data storage. With the block diagram describe the characteristics of data logger. [1+4]
6. Explain different types of filtering based on frequency, mode (common and differential) and amplitude (surge suppression). [6]
7. While selecting a processor for an embedded system product, you have to specify the performance, number of peripherals functions, memory and tool support to determine the appropriate processor for the product. As a system designer, provide a technical explanation for each of these factors required to achieve the proper functional design. [6]
8. What are general guidelines to avoid the crosstalk while routing signal traces on Printed Circuit Board? What are the problems due to impedance mismatch? [4+2]
9. What is software reliability? Compare waterfall and prototyping model. Describe Embedded and Real Time Software. [2+3+3]
10. Answer the following questions with regard to your case study.
 - a) Design a proposed system using microprocessor/microcontroller input/output devices, interfacing process, communication protocols, data converters and handshake signals with neatly labeled block diagram. [6]
 - b) Mention different types of problems that might occur after implementing the recommended setup and probable mitigating factors to overcome these problems. [6]

2074 Chaitra

Year / Part	III / I	Time	3 hrs.
-------------	---------	------	--------

Subject: - Instrumentation II (EX602)

- ✓ Candidates are required to give their answers in their own words as far as practicable.
- ✓ Attempt All questions.
- ✓ The figures in the margin indicate Full Marks.
- ✓ Assume suitable data if necessary.

1. a) Describe various well-known techniques while interfacing an I/O device with a personnel computer system. [3]
b) Differentiate I/O mapped I/O and memory mapped I/O with suitable examples. How can you generate I/O mapped and memory mapped signals using IO/M, RD and WR signals? [5]
2. Explain the different schemes of parallel data transfer with suitable timing diagram. Explain the functional block diagram of 8255A PPI with neat diagram. [4+4]
3. a) Describe the various error detection techniques used in serial data transmission. [3]
b) Explain the functions of USB Host, USB Hub and USB Device. Discuss different packets used in USB protocol. [5]
4. What are the different types dynamic errors in ADC and DAC? What will be the control word for interfacing as shown figure below? Also write the subroutine program to read the digital data from ADC. [4+6]

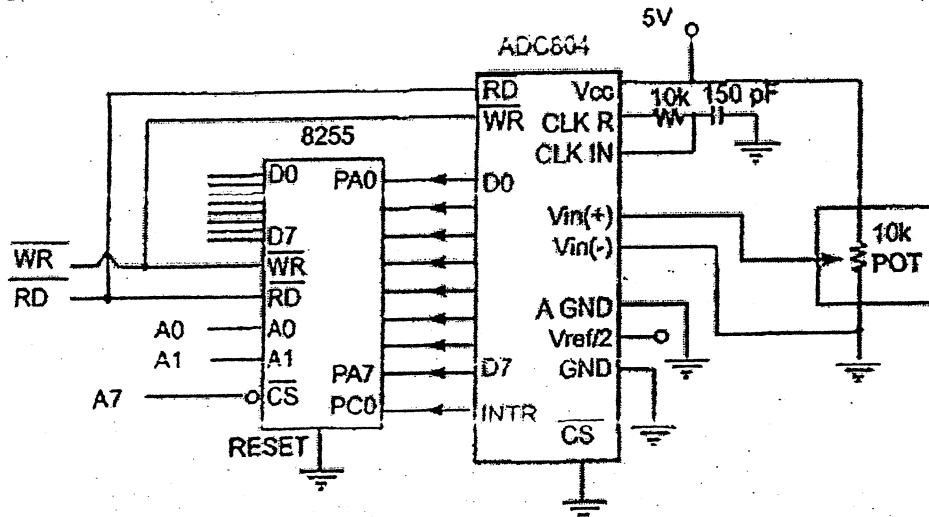

5. Explain the advantages of optical fiber over copper wire? Explain each block of data logger. [2+6]
6. a) What are the different noise coupling mechanism? [3]
b) How can you reduce the conductive noise coupling? Explain in detail. [3]
7. What are general approaches of establishing requirements for circuit design? What are the two factors that drive reliability of a product? [4+2]
8. Poor circuit layout and signal propagating principle may cause many problems in the circuit operation, manufacturing ease and probability of design errors. What factors will you consider while routing the signal traces on PCB. [6]
9. Explain Prototyping Model for software development in brief. Explain different phases of introduction of bugs in software. [3+5]
10. Describe the different processing plants that you have studied in case study. With neat and clean block diagram explain how the further improvement of these plants can improve the performance of the overall system. [12]

Exam.	Back		
	Level	BE	Full Marks
Programme	BEL, BEX, BCT	Pass Marks	32
Year / Part	III / I	Time	3 hrs.

Subject: - Instrumentation II (EX602)

- ✓ Candidates are required to give their answers in their own words as far as practicable.
- ✓ Attempt All questions.
- ✓ The figures in the margin indicate Full Marks.
- ✓ Assume suitable data if necessary.

- (1) If the speeds of I/O devices do not match the speed of the microprocessor, what types of data transfer techniques are used? Describe them with necessary block diagrams and control signals. [6]
- (2) A microprocessor kit has an onboard 8255. Interface to the 8255 eight single-pole-double-throw (SPDT) switches numbered S0 to S7 and a seven segment common anode LED display. Draw the complete circuit setup. Define clearly the functions of all ports, write a program to initialize 8255, detect a switch closure, and display the value of the switch number on the LED display. [8]
- (3) (a) Explain the design of a USB to RS-232 adapter with the aid of a neat circuit diagram, appropriate voltage translation chips, and necessary handshake/control signals. [6]
 (b) What is the time required for transmission of a character with one start bit, seven data bits, one parity bit, and one stop bit with 1200 baud? [2]
- (4) The data converter that is being used in your project is suffering from differential nonlinearity and harmonic distortion. Instead of purchasing a new converter, you are required to use the defective converter. Discuss technical measures that can be implemented to mitigate the aforementioned errors. [6]
- (5) Signals from three different transducers need to be recorded in a data logger. The analog signals supplied by the three transducers are dual polarity (- 50 mV to 50 mV) having frequencies of 5 KHz, 10 KHz and 15 KHz. Explain the design of the following stages of the data logger:
 (a) Input scanner stage of the data logger such that it can appropriately sample the incoming signals [3]
 (b) Signal conditioner stage if the 8-bit ADC used inside the data logger accepts only positive polarity signals ranging from 0 volts to 5 volts. [3]
- (6) Explain the mechanism of filtering line noise with the aid of chokes. How does a choke differentiate between the signal that it needs to pass and the noise that it needs to suppress? Describe the circumstances where chokes are preferred over other noise filtering approaches. [8]
- (7) During circuit design process, what are some general technical dilemmas faced by engineers? Explain how an engineer can arrive at an optimal solution given the requirements of a customer? [8]
- (8) (a) In a multi-layer PCB, describe how grounding is performed and how coupling amongst the layers is minimized. [4]
 (b) A faulty computer motherboard has severe clock jitter. The crystal producing the clock pulses is functioning properly, but clock signals arriving at various motherboard chips suffer from jitter. Discuss the source of the problem and provide some remedies. [4]
- (9) (a) Discuss the shortcomings of existing software development models, and suggest measures to overcome them. [5]
 (b) The testing time for software cannot be too long, yet software needs to be thoroughly tested before it can be commercialized. Explain how this paradox is overcome in a real-world software development environment. [5]
- (10) Answer the following questions with regard to your case study:
 (a) Discuss the main architectural differences between the existing system and the proposed system. [2]
 (b) Does your proposed system use a microcontroller or a microprocessor? Justify your choice, and make a neatly labeled block diagram of your proposed system. [3]
 (c) In your proposed system, explain in detail the interfacing process of peripheral devices with the microcontroller or microprocessor in terms of data format, data rate, data converters, communication protocols, timing diagrams, and handshaking signals. [5]
 (d) List the technical drawbacks present in your proposed design. [2]

Exam.	Regular		
Level	BE	Full Marks	80
Programme	BEL, BEX, BCT	Pass Marks	32
Year / Part	III / I	Time	3 hrs.

Subject: - Instrumentation II (EX602)

- ✓ Candidates are required to give their answers in their own words as far as practicable.
- ✓ Attempt All questions.
- ✓ The figures in the margin indicate Full Marks.
- ✓ Assume suitable data if necessary.

1. a) Define Microprocessor Based Instrumentation System. Explain, with suitable example, why microcomputer is an important consideration in instrumentation design. What are the basic features of microprocessor based instrumentation system? [1+2+2]
- b) Explain the interrupt driven data transfer scheme. [3]
2. a) List out the technical benefit of using 8255 PPI in MBI system. Explain PCI bus in brief. [2+2]
- b) Explain how the base address of 8255A is changed with change in address lines of 8085 connection with 8255A? [3]
3. a) Describe the functions of RS-232C signals used in handshaking. Why RS-422A can transfer data in longer distance and at higher rate than RS-232C? [1+3+1]
- b) Explain USB-OTG in brief. Discuss the types of data packets in USB protocol. [2+3]
4. a) Why analog signals need to be transferred to digital? What are the errors associated with ADC and DAC? [1+3]
- b) Explain the way you can interface a 10-bit DAC with 8085. [4]
5. a) Explain the characteristics of data logger. [4]
- b) Explain the Bluetooth network topology. [4]
6. a) How can you protect a circuit from electrostatic discharge? [2]
- b) A new model sports car had a disconcerting problem: occasionally the dashboard lights would all illuminate simultaneously. Two service calls later, replacement of a wire harness for the spark plugs solved the problem. Explain what the coupling mechanism was and how it can be reduced? [6]
7. Kathmandu Milk Supply Scheme has planned to automatize the milk refilling process. As an engineer, what would be your design considerations to reduce the probability of failure of the system? [5]
8. What is crosstalk? Explain the guidelines for low power design. [1+5]
9. Explain the approach for good programming practice. What are the basic criteria for selecting a company for purchasing reliable software? [4+4]
10. Discuss the current control mechanism of the industrial process control system involved in your case study with the help of block diagram. What was your recommendation for further improvement of this system? Explain why the management should implement your recommendation. Do you foresee any problems after implementing this control system? [12]

Exam.	New Back (2066 & Later Batch)		
Level	BE	Full Marks	80
Programme	BEL, BEX, BCT	Pass Marks	32
Year / Part	III / I	Time	3 hrs.

Subject: - Instrumentation II (EX602)

- ✓ Candidates are required to give their answers in their own words as far as practicable.
- ✓ Attempt All questions.
- ✓ The figures in the margin indicate Full Marks.
- ✓ Assume suitable data if necessary.

1. a) Explain the features of microprocessor based instrumentation system. [3]
 b) Differentiate between open loop and closed loop instrumentation system along with block diagrams. [5]
2. Assume that your group has decided to make microprocessor based instrumentation system for an Ice Cream Factory using an 8255 PPI card at base address 5000H in memory mapped I/O mode for controlling purpose. You need to measure pressure and temperature of a manufacturing plant. [1+1+2+2+4]
 - i) List out the collected documents and components.
 - ii) List out different signals you need to derive and or can be directly connected to your interfacing circuit.
 - iii) Draw minimum mapping circuit for above system
 - iv) What are the addresses captured by your card? Generate the control word for the system
 - v) Write a program module for measuring temperature and control if the temperature is not in the range. Assume suitable data if necessary.
3. a) Explain why system that uses the RS 422A can transmit data over longer distance and at higher baud rate than Rs 232C and RS 423A. [4]
 b) The fundamental elements of communication on the USB data Bus is a packet. Discuss various types of packets used in USB protocol. [4]
4. a) Why analog signal needs to be converted to digital? What are the selection criteria for selecting ADC? [2+2]
 b) What are the characteristics of ADC and DAC? [4]
5. a) What is spread spectrum frequency hopping in Bluetooth? Write the application of Bluetooth. [1+2]
 b) What is data logger? Explain the operation of data logger along with its block diagram. [5]
6. How inductive noise is introduced in electronic system? Discuss the shielding mechanism for capacitive coupling. [3+3]
7. Establishing requirements is the most difficult part of circuit design. What could be the basic tips and thoughts for setting requirements towards selecting the appropriate technology which help you to achieve a new circuit design? [6]

8. Write about the factors we should consider while doing component placement. Explain the role of grounding and shielding to reduce noise in PCB. [3+3]
9. The essential components of software development interact in different ways in different process models which helps to plan the development of a project and estimate the effort for it. Describe different types of software models used in Software Development platform. Also mention the merits and demerits of each model. [8]
10. What changes do you recommend in the visited industry during your case study? Why do you think that the management should implement these changes? Assume that you have a senior reporting engineer closely looking at work from the system development level, apart from convincing the management team at the visited industry to implement new system, you also need to convince the senior engineer technically so that your recommendations will be implemented. How do you want to achieve this technically? Debate on your technical design to replace the current system and also relate probable problems you might face after system implementation. [12]

Exam.	Regular		
Level	BE	Full Marks	80
Programme	BEL, BEX, BCT	Pass Marks	32
Year / Part	III / I	Time	3 hrs.

Subject: - Instrumentation II (EX602)

- ✓ Candidates are required to give their answers in their own words as far as practicable.
- ✓ Attempt All questions.
- ✓ The figures in the margin indicate Full Marks.
- ✓ Assume suitable data if necessary.

1. a) What do you understand by a closed loop MBI system? [1]
- b) Differentiate unique vs non unique address decoding. [4]
- c) Specify the addresses for the ports of 8255PPI shown in figure below. [3]

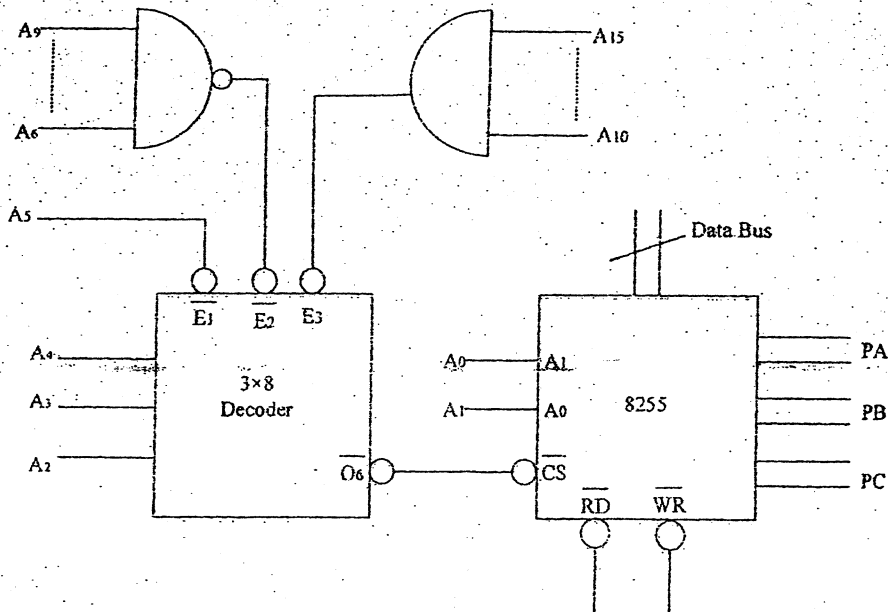

2. a) List out the technical benefits of using 8255 PPI in a MBI system. [2]
- b) With a neat timing diagram and an appropriate example, explain the operation of 8255 PPI in mode 2. You should clearly show the necessary control signals and an interfacing circuit to connect 8255PPI to 8085 microprocessor. Also write the necessary control words to configure the 8255 in this fashion. [3+3+2]
3. a) What are the errors associated with serial data transfer and their error checking mechanism? [4]
- b) What is USB on the Go? Write short note on USB packet types. [1+3]
4. a) With necessary illustrations, explain the cause behind the DNL and INL errors in A/D and D/A conversion. [2]
- b) Interface a suitable DAC using 8255 PPI to a 8085 microprocessor to generate a square wave oscillating between 0V and -5V having a frequency of 1 KHz. Show the interfacing circuit and the necessary program. [3+3]

5. A datalogger receives signals from Bluetooth Scatternet which consists of different Bluetooth devices. The data retrieved needs to be transmitted via optical fiber links.
- What is frequency hopping? Relate it with the Bluetooth technology. [2]
 - Write in brief about the typical characteristics of a datalogger. [3]
 - Draw a neat and labelled block diagram of the complete system. [2]
 - Compare and contrast the terms data archiving and data storage. [1]
6. a) Explain the remedial strategies for various energy coupling mechanisms. [4]
- b) An electronic circuit receives noise from a switching element. If voltage on the switching device swings from 4V to 6V within 100 μ s, during which current makes a transition from 10 μ A to 25 μ A in 10 ns, what might be the noise coupling mechanism? Identify it using suitable calculations. [2]
7. DOECE is looking for an expert engineer to work in the research projects of high frequency, high speed applications. What guidelines would you suggest as an engineer to design high speed and high frequency circuits? Explain in detail. [6]
8. Circuit boards combine electronic components and connectors in to a functional system through electrical connections and mechanical support. Explain the factors that need to be considered while creating traces to connect the electronic components. [6]
9. A software company is planning to make new software. Suggest good procedure to develop software. Explain different types of software models. [3+5]
10. Draw the complete block diagram of the industrial process control involved in your case study. What are the critical factors affecting the production you have noticed in the visited industry and what are the measures can you suggest for the same? Also mention advantages and disadvantages of suggested system. [12]

Exam.	New Back (2066 & Later Batch)		
Level	BE	Full Marks	80
Programme	BEL, BEX, BCT	Pass Marks	32
Year / Part	III / I	Time	3 hrs.

Subject: - Instrumentation II (EX602)

- ✓ Candidates are required to give their answers in their own words as far as practicable.
- ✓ Attempt All questions.
- ✓ The figures in the margin indicate Full Marks.
- ✓ Assume suitable data if necessary.

1. a) "Microprocessors are indispensable tools in modern industrial instrumentation systems". As an engineer, provide a technical explanation including block diagrams to this statement by relying on observations from your case-study. [4]
- b) What benefit are obtained from a memory-mapped I/O design? Design an interface arrangement for 8085 microprocessor to map output ports in address space 1000H to 2000H and input ports in address space 3000H to 4000H. [4]
2. a) Consider a double handshake scheme that allows data transfer from an input peripheral device to an 8085-microprocessor through an 8255-PPI. [5]
 - i) List all control signals that get exchanged between the devices.
 - ii) Draw a detailed timing diagram showing the exchange of control and data signals. Include the cause and effect arrows in your timing diagram.
 - iii) With a neat sketch how the overall system diagram between the modules mentioned above
 - iv) Generate an appropriate control word based upon your drawing and derive the address of the control register of the 8255-PPI used in your design.
- b) List the control signals used by the ISA bus. Provide convincing arguments to justify the replacement of the ISA bus by the PCI bus. Calculate the bandwidth of a 64 bit PCI bus operating at 66-MHz. [3]
3. a) What are the criteria should be involved during the design of RS-232A in Simplex, Half Duplex and Full Duplex modes. [4]
- b) Explain the USB signals and associated bus states. Also mention the signal levels to achieve these bus states. [4]
4. a) Why do we need to digitize a signal? What are the errors associated with A/D or D/A converters? [6]
- b) What are the selection criteria for A/D or D/A converter? [2]
- c) To convert an analog signal into digital form, 8-bit ADC is used. The ADC has eight input channels, and channel four is used to capture the incoming analog signal. The address of the desired channel is sent through pins PB0, PB1 and PB2. After at least 50-nanoseconds, this address must be latched. The latching signal is sent using PB4. After another 2.5-microseconds, PB3 is used to initiate the conversion process. The completion of the process is signaled via PC5. The output latch of the ADC can be enabled through PB6, and digital data can be read through port A of 8255-PPI. [8]

- i) Draw a circuit showing the interfacing of the ADC module, 8255-PPI and 8085 microprocessor on the basis of the connections described above.
 - ii) Draw the timing waveforms of all the control and data signals involved in the process.
 - iii) Provide a flowchart that depicts the ADC process
 - iv) Derive port addresses from your circuit diagram and provide the control word
5. a) In high-speed circuits, "ground" is a meaningless concept, the important question is, "what path does return current follow?" Justify the above statement with proper reasons and examples. [4]
- b) Discuss the importance of an interface unit. What factors need to be accounted for while designing input and output interface units? [4]
6. a) Define impedance matching. What is the impact of impedance discontinuities? [2]
- b) How do you reduce crosstalk when routing signal traces on a PCB? [4]
7. What are the basic principles of signal propagation and circuit layout for Routing Signal Traces which are predominant of effective circuit layout? [6]
8. Programs are to be read by humans. For programs to be useful, reliable and maintainable, you must make them readable and understandable. Good design and programming practices can make programs more readable. Explain in brief how you can make programs more readable. [8]
9. Answer the following questions with respect to your case study: [12]
- i) What is techno-commercial feasibility of a system? Provide examples from your case-study experience.
 - ii) List the major technical drawbacks present in the existing MBI system that you witnessed at the industrial site.
 - iii) Give at least three feasible technical solutions to overcome the drawbacks that you witnessed. Show how your solution will offer higher reliability and incorporate fault-tolerant design practices. Include block diagrams.
 - iv) If you had to present your design to the company's management team, what sort of question would you anticipate? Provide a list of at least five questions that would be asked from a management point of view. How would you cope with the questions, and how would you convince the team to accept your design?
 - v) Repeat part (d), but now you are trying to convince senior engineers. How will the question and answer session change compared to part (d)?
 - vi) Compare and contrast your design with the existing design in terms of the following metrics: cost/performance ratio, technical specifications (hardware and software) and design complexity (provide diagrams)

Exam.	Regular		Full Marks	80
Level	BE		Pass Marks	32
Programme	BEL, BCT	BEX	Time	3 hrs.
Year / Part	III / I			

Subject: - Instrumentation II (EX602)

- ✓ Candidates are required to give their answers in their own words as far as practicable.
- ✓ Attempt All questions.
- ✓ The figures in the margin indicate Full Marks.
- ✓ Assume suitable data if necessary.

1. a) How do you select a microprocessor or a microcontroller for your project? [3]
 b) Explain the block diagram of a microprocessor based instrumentation system. What are the basic features of a microprocessor based instrumentation system? [5]
2. a) Write a short note on PCI Bus. [2]
 b) Interface a keyboard and a printer in mode 1. Port A is designed as input for keyboard with interrupt I/O port B is designed as output for printer with status check I/O. Draw the mapping circuit and write the control word and address map. [6]
3. a) Design a cable that has a USB connector at one-end and an RS-422 connector at the other end. Assume the USB is connected to a laptop and the RS-422 connector is attached to a printer. Your design should include the following: [6]
 - i) Technical names of the pins and wires involved in the design.
 - ii) Intermediate chips to maintain voltage uniformity between the two standards.
 - iii) Neat and labeled sketch of the wiring between the two standards.
- b) What is a USB interface chip? Why are they required? Compare and contrast USB device interface chips and USB host interface chips. [4]
4. a) Calculate the values of the LSB, MSB, resolution and full-scale output for an 8-bit DAC for the 0 to 10V range. [2]
 b) How can you design a DAC with 12 bit resolution with the 8085 microprocessor having 8 bits data lines? Explain with suitable block diagram. [6]
5. a) What are the essential components of data acquisition system? Explain with the help of block diagram. [4]
 b) Explain Bluetooth network topology in brief. What are the advantages of Bluetooth applications? [4]
6. a) What are the characteristics of a safety ground? [2]
 b) Describe different types of noise coupling mechanism in brief. How do you check their predominance in the circuit? [4]

7. A data logger receives signals from a Bluetooth scatternet. The scatternet consists of three piconets and within each piconet there are four bluetooth devices. The piconets communicate within themselves and amongst each other using the master/slave protocol. [10]
- a) Describe an analog transmission mechanism to capture the blue tooth signals by the data logger. Draw a complete system block diagram.
 - b) Describe the mater/slave protocol that is present in blue tooth piconets and scatternets
 - c) Draw the scatternet topology depicting the scenario maintained in the question. Make sure you adhere to the rules of the masters/slave protocol.
8. a) While designing an electronic instrument you should group circuits according to their characteristics to maintain the correct operation of each circuit. What are the considerations during grouping components and circuits and what is the impact of such grouping? [4]
- b) What are the factors that derive reliability of an electronic system? [2]
9. Compare and contrast the three traditional models of software development with respect to their strengths and weaknesses. Propose a fourth software development model that outperforms the classical methods and justify your choice in terms of reliability, maintainability, flexibility, portability and reusability. [4]
10. Draw the complete block diagram of industrial process control system involved in your case study. Explain why you want to implement this control system over existing one in terms of cost, manpower and plant automation. What problems you might face after implementating this control system. [12]

Exam.	New Back (2066 & Later Batch)		
Level	BE	Full Marks	80
Programme	BEL, BEX, BCT	Pass Marks	32
Year / Part	III / I	Time	3 hrs.

Subject: - Instrumentation II (EX602)

- ✓ Candidates are required to give their answers in their own words as far as practicable.
- ✓ Attempt All questions.
- ✓ The figures in the margin indicate Full Marks.
- ✓ Assume suitable data if necessary.

1. Draw and explain the block diagram of microprocessor based instrumentation system. Also list out advantages of implementing an MBI system. Explain briefly the concept of DMA. [4+2+2]
2. Assume that your group has decided to make a PC based instrumentation control system for automatic concrete purifying factory using an 8255 PPI card at base address 4000H in memory mapped I/O mode for controlling purpose. [1+1+2+2+4]
 - a) List out the collected documents and components.
 - b) List out the different signals you need to derive and or can be connected directly to your interfacing circuit.
 - c) Draw minimum mapping circuits for the above system.
 - d) What are the addresses captured by your card? Generate the control word for the system.
 - e) Write a program module to read ten set of raw data from port A and port B; add the data and store the result starting from address 4040H.
3. a) Describe the problem that occurs when you attempt to connect together two Rs.232 devices that are both configured as DTE. Draw a diagram which shows how this problem can be resolved. [5]
 - b) Explain USB protocols which should be followed during the USB design. [5]
4. What are characteristics of A/D or D/A converters? With necessary diagram explain the interfacing of 10 bit DAC with 8085 along with timing diagram. [2+4]
5. a) What is data logger? Explain the characteristics for a data logger. [5]
 - b) Write the advantages and disadvantages of optical fiber communication. [3]
6. Elucidate the principle of grounding? Mention how many configurations are available to provide the basic principle of grounding. [1+5]
7. a) What are the reasons for using low power design? [2]
 - b) Write about ground bounce, cross talk, impedance matching and timing skew. [4]
8. Fault tolerance reduces possibility of dysfunction or damage from abnormal stresses and failure. It has three distinct areas: careful design, testable functions and redundant architecture. Explain how we can avoid many failures using these three approaches. [6]
9. IOE is planning to apply new software for its database management system. Suggest the best selection and purchase procedure? Explain in detail about good programming practice. [3+5]
10. What have you learned from case study? Draw the complete block diagram of the industrial process control involved in your case study. What are the critical factors affecting the production you have noticed in the visited industry and what measures can you suggest for the same? What problems you might face after implementing your suggested process control system. [12]

Exam.	Regular		
Level	BE	Full Marks	80
Programme	BEL, BEX, BCT	Pass Marks	32
Year / Part	III / I	Time	3 hrs.

Subject: - Instrumentation II (EX602)

- ✓ Candidates are required to give their answers in their own words as far as practicable.
- ✓ Attempt All questions.
- ✓ The figures in the margin indicate Full Marks.
- ✓ Assume suitable data if necessary.

1. Describe the various PC interfacing techniques involved while interfacing an I/O device with a PC. Differentiate closed loop microprocessor based system over open loop microprocessor based system. [3+4]
2. Explain briefly about PCI bus. [3+6]

The base address for the interfacing circuit given below is 5500 H:

- a) Identify the Port address
- b) Write the necessary control words to initialize the 8255
- c) Draw the timing diagram for the configuration as shown in figure below.

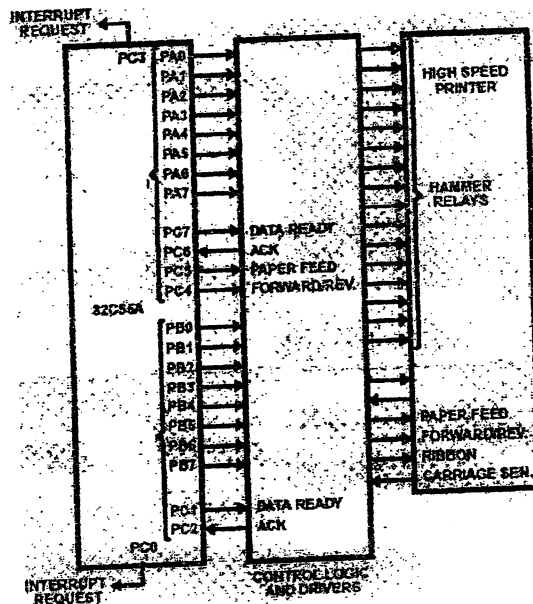

3. a) Explain how communication takes between two data terminal equipment in NULL modem connection. [4]
- b) Compare between RS 232C, RS422A and RS423A. [4]
- c) Compare the standards: USB1.1 and USB 2.0 [2]
4. Explain the error associated with A/D and D/A converters. [8]

5. What are the components used in Data Acquisition system, explain with necessary block diagram. Why optical fiber is dominating the other guided medium used in data transmission schemes. [5+3]
6. a) Describe the working principle of decoupling capacitor in short. [2]
b) Explain different types of noise coupling mechanism. [4]
7. Starting from the converting the requirement into design, Explain the procedure of designing electronics circuit. [6]
8. Write about the factors we should considered while doing component placement. What rule does a designer have follow while routing signal tracks in PCBs in order to avoid the effect of impedance mismatch and cross talk. [3+3]
9. Once you have tested, verified and release software, you have to maintain it. As with testing, you cannot separate software maintenance from system concerns. Discuss at length how you get common bugs in software and develop a good corrective action to fix software bugs in your distributed software. [8]
10. Explain existing system involved in your case study with necessary block diagram. What was your recommendation over the existing system in term of cost, manpower and plant automation. [12]

Exam.	INSTITUTE OF ENGINEERING		
Level	BE	Full Marks	80
Programme	BEL, BEX, BCT	Pass Marks	32
Year / Part	III / I	Time	3 hrs.

Subject: - Instrumentation II (EX502)

- ✓ Candidates are required to give their answers in their own words as far as practicable.
 - ✓ Attempt All questions.
 - ✓ The figures in the margin indicate Full Marks.
 - ✓ Assume suitable data if necessary.
1. Draw and explain the block diagram of microprocessor based instrumentation system. Also, list out advantages of implementing an MBI system in industrial plants for control and automation. [4+4]
 2. The addresses captured by 8255 PPI are A0A0H to A0A3H. Sketch the interfacing circuit with 8085 microprocessor in memory mapped I/O for same. What will be the control words for following configurations of 8255 PPI? [4+4]
 - a) Port A: Mode 0 output
Port B: Mode 0 input
Port C: Mode 0 output
 - b) Port A: Mode 1 output
Port B: Mode 1 input
PC_{4,5}: output
 - c) Port A: Mode 2
Port B: Mode 1 output
 - d) Set PC5 in BSR mode
 3. a) Serial data transfer mechanisms are much more complicated than parallel data transfer mechanisms. But still, serial data transfers are preferred over parallel data transfers. Why? [2]
 - b) How can serial data transfer using RS423A standard transfers data at longer distances compared to RS232A standard for the same data rates? [2]
 - c) What is On-The-Go protocol in USB 2.0? Explain the basic data transfer mechanisms used in USB standards? [2+4]
 4. Explain the error associated with A/D and D/A converters. [8]
 5. a) What are the characteristics of Compact data logger? Explain with block diagram. [6]
 - b) What are piconet and scatternet in Bluetooth device? [2]
 6. a) What is a ground loop? How can we eliminate them? [1+1]
 - b) A commercial bank has placed its ATM counter inside a 5-star hotel. Customers would walk through carpeted hallways to reach the ATM and insert their debit card into the machine to retrieve cash. However, the bank faced a disturbing problem: the electronics in the card reader circuitry was failing frequently causing an adverse effect to the bank's reputation. What could have caused the problem? Explain the measures to prevent this problem. [2+2]
 7. Explain how the reliability of a circuit can be increased by using testable architectures and redundant architectures in circuit design. [3+3]
 8. How can cross talk can be minimized during routing the signal trace in PCB, Describe with trace impedance matching techniques. [6]
 9. a) Most microprocessor based systems use embedded, real time softwares for processing. How can you increase the reliability of such softwares? [3]
 - b) Spiral model of software development combines the elements of both waterfall and prototyping model. Explain the process of software development using spiral model. [5]
 10. Draw and explain the block diagram of existing industrial process control system. Explain your proposed system with advantages. [6+6]

Exam.	Regular		
Level	BE	Full Marks	80
Programme	BEL, BEX, BCT	Pass Marks	32
Year / Part	III / 1	Time	3 hrs.

Subject: - Instrumentation II (EX602)

- ✓ Candidates are required to give their answers in their own words as far as practicable.
- ✓ Attempt **All** questions.
- ✓ The figures in the margin indicate **Full Marks**.
- ✓ Assume suitable data if necessary.

1. Explain briefly the concept of DMA. Draw circuit Diagram of an interfacing circuit containing 4 KB ROM and 8 KB RAM. Assuming Base address in 4000H. You also need to draw write and read cycle timing diagram. [2+6]
2. In a microprocessor based system, an 8255A PPI card is used to interface a keyboard and a printer to the processor. The 8255A PPI is interfaced with the 8085 microprocessor in the system such that the base address of 8255 A PPI is 4044 H.
 - a). What are the addresses captured by the card? [1]
 - b) Draw the complete interfacing circuit of 8255A PPI with 8085 microprocessor for the given system. [3]
 - c) If the printer is interfaced to port A and the keyboard is interfaced to port B of the PPI generate the control word to initialize the 8255A PPI with proper explanations. Both printer and keyboard use 8-bit parallel data transfer with handshaking. [2]
 - d) Derive the control word to enable interrupt request to the microprocessor by port A of 8255A PPI in above system, with proper explanations. [2]
3. a) Compare the USB standards: USB 1.1 and USB 2.0 [3]
 b) Describe simplex, half duplex and full duplex operation using RS-232 port. [7]
4. What are types of errors present in a A/D or D/A converters? With necessary diagram explain the interfacing a ADC using interrupt. [3+5]
5. a) Explain different network topologies of Bluetooth device with appropriate diagrams. [4]
 b) What is a data logger? Explain the desirable characteristics for a data logger. [1+3]
6. Explain different types of Noise coupling Mechanism with concept of Pseudo impedance. [6]
7. What are the reasons for using low power? Mention the guidelines to be considered for low power design. [2+4]
8. A careful circuit layout not only makes the production of circuit boards easier but also makes them less error prone. What rules does a designer have to follow while routing signal tracks in PCBs in order to avoid the effects of impedance mismatch and crosstalk? [3+3]
9. What is fault tolerance in software? What do you mean by roll-back recovery and roll-forward recovery? Explain different types of bugs in software. [2+2+4]
10. a) What are the types of Microprocessor based system used in instrumentation system? How it makes more benefits in industry? [3]
 b) Explain detail about different processing plant which you have studied in case study. Also draw the block diagram for further improvement of these all plant and overall system. [9]

TRIBHUVAN UNIVERSITY
INSTITUTE OF ENGINEERING
Examination Control Division
2079 Bhadra

Exam.	Regular		
Level	BE	Full Marks	80
Programme	BEL, BEX, BCT, BAG	Pass Marks	32
Year / Part	III / I	Time	3 hrs.

Subject: - Communication English (SH 601)

- ✓ Candidates are required to give their answers in their own words as far as practicable.
- ✓ Attempt All questions.
- ✓ The figures in the margin indicate Full Marks.
- ✓ Assume suitable data if necessary.

1. Edit the following text. [5]

I count it as nothing, he told his sympathizers his eyes on the rope he was tying. What is egg-rasher Did I depend on it last week Or is it greater than other things that went with the war I say, let egg-rasher perish in the flames!

2. Read the following text carefully and interpret it so as to make the meaning clear. [5]

The survival of the publishing industry depends upon the existence of a public who will buy the printed word in the form of newspapers, books and magazines. Over the past several years, however, the advance of electronic media, particularly CD-ROMs, online computer services, and the internet, has made information available to the public electronically without the need for printed materials. As the availability of electronic media increases and as it is more easily accessible, the public has less need for printed materials.

3. Read the given passage carefully. And prepare notes and summary. [5+5]

The world needs to dramatically reduce its greenhouse gas emissions and fast, if there's any hope of preventing worse and more frequent extreme weather events. That means shifting to renewable sources of energy – and, importantly, decarbonizing transportation, a sector that is now responsible for about a quarter of the world's carbon dioxide emissions. But the path to that cleaner future is daunting, clogged with political and societal roadblocks, as well as scientific obstacles. Perhaps that's one reason why the electric vehicle – already on the road, already navigating many of these roadblocks – swerved so dramatically into the climate solutions spotlight in 2021.

Just a few years ago, many automakers thought electric vehicles, or EVs, might be a passing fad, says Gil Tal, director of the Plug-in Hybrid and Electric Vehicle Research Center at the University of California, Davis. It's now clear to everyone that [EVs are] here to stay. Globally, EV sales surged in the first half of 2021, increasing by 160 percent compared with previous year. Even in 2020 - when most car sales were down due to the COVID-19 pandemic – EV sales were up 46 percent relative to 2019. Meanwhile, automakers from General Motors to Volkswagen to Nissan have outlined plans to launch new EV models over the next decade: GM pledged to go all - electric by 2035, Honda by 2040. Ford introduced electric versions of its iconic Mustang and F - 150 pickup truck.

“Consumer demand for EVs isn't actually driving the surge in sales”, Tal says. The real engine is a change in supply due to government policies automakers to boost their EV production. The European Union's toughened CO₂ emissions laws for the auto industry went into effect in 2021, and automakers have already bumped up new EV production in the region. China mandated in 2020 that Evs make up 40 percent of new car sales by 2030. Costa Rica has set official phase-out targets for internal combustion engines.

4. Answer any two of the following questions: [2×5]
- How do studies groom up the natural intelligence of human being?
 - Why is scientific attitude? Why is it required for everyone?
 - Describe the technical process of refining the crude petroleum.
5. Choose the correct words from the brackets. [10×0.5]
- Stones are dumb unless man them speak. (made/makes)
 - It would have been better if they (would not come/ had not come).
 - He, accompanied by other members of the team, arrived. (has/ have)
 - The police arrested the suspected criminal. (has/ have)
 - He sat the shade of a tree. (in/ under)
 - The baby climbed the table. (into/ onto)
 - The train started after we for an hour. (played/ had played)
 - No sooner had he left the office than the heavy rainfall (started/ would start)
 - The passive form of "No one could see that" is(That could not be seen/ That could be seen by no one)
 - The passive form of "His conduct shocked me" is(I was shocked as his conduct/ I was shocked by his conduct)
6. Document the given details in MLA and APA style. [2+2]
- Name of the book: Living Stories, Telling Lives
 Name of author: Joanne S. Frye
 Date of publication: 1986
 Place of publication: Ann Arbor
 Publisher's name: University of Michigan press
7. Suppose you are the secretary of the newly formed club of your college. Write the minutes of the third meeting held recently in inventing four agenda for the organization of technical exhibition. [5]
8. You have participated in one day seminar on "The Future of Alternative Energy in Nepal" conducted by an international agency. Prepare a field report in letter format to submit to your company. [6]
9. Write title page, abstract, scheduling and cost estimate to submit a proposal for improving the existing parking facilities for the four wheeler and two wheeler vehicles in your local town. [10]
10. Write a report of your study on Unplanned Urbanization of Kathmandu City to submit to the Mayor of Kathmandu Metropolitan. Prepare only the title page, letter of transmittal, acknowledgement and recommendations. [10]
11. Write in 500 words a research article on "Nano Pollution and its Solution". [10]

TRIBHUVAN UNIVERSITY
INSTITUTE OF ENGINEERING
Examination Control Division
2079 Baishakh

Exam.	Back		
Level	BE	Full Marks	80
Programme	BEL,BEX,BCT,BAG	Pass Marks	32
Year / Part	III / I	Time	3 hrs.

Subject: -Communication English (SH 601)

- ✓ Candidates are required to give their answers in their own words as far as practicable.
- ✓ Attempt All questions.
- ✓ The figures in the margin indicate Full Marks.
- ✓ Assume suitable data if necessary.

1. Edit the following text.

[5]

How stupid and worrying it is he thought when he wake up and look at the dark windows ... here I have have a good sleep for some reason. What shall I do tonight.

2. Read the given text and interpret its meaning;

[5]

The forms and functions of verbal communication vary significantly around the world and reflect striking differences in values and beliefs. These culturally learned patterns usually function on a highly unconscious level and can result in serious conflict, misunderstanding, and negative stereotyping when people from different cultures interact. To minimize such tensions and problems and to enhance intercultural communication, international travelers should be aware of their own speaking style and the ways it differs from that of the culture they are visiting. By increasing their knowledge of what people in the host country tend to say and how they tend to say it, international visitors will be able to traverse the minefield of cultural differences and adjust to the new environment more easily.

3. Read the following text carefully; make notes and write summary after a close reading.

[5+5]

Modernization has generally enhanced the material level of civilization through out the world. But has it also enhanced the moral and cultural dimension of civilization? In some respects, this appears to be the case. Slavery, torture, vicious abuse of individuals, have become less and less acceptable in the contemporary world. Is this, however, simply the result of the impact of western civilization on other cultures and hence will a moral reversion occurs as western power declines? Much evidence exists in the 1990s for the relevance of the "sheer chaos" paradigm of world affairs: a global breakdown of law and order, failed states and increasing anarchy in many parts of the world, a global crime wave, transitional mafias and drug cartels, increasing drug addiction in many societies, a general weakening of the family, a decline in trust and social solidarity in many countries, ethnic religious, and civilizational violence and rule by the gun prevalent in much of the world. In city after city-Moscow, Rio de Janerio, Bangkok, Shanghai, London, Rome, Tokyo, Delhi, Karachi, Cairo, Washington-crime seems to be soaring and basic elements of civilization fading away.

People speak of global crisis of governance. The rise of transitional corporation producing economic goods is increasingly matched by the rise of transitional criminal mafias, drug cartels, the terrorists gangs violently assaulting civilization. Law and order is prerequisite of civilization and in much of the world-Africa, Latin America, South Asia, the former Soviet Union, the middle east-it appears to be evaporating. On a worldwide basis civilization seems in many respects to be yielding to barbarism, generating the

image of an unprecedented phenomenon, a global dark age, possibly descending on humanity.

4. Answer any two of the following questions. [2×5]

- a) How do aerofoils function to control the aircraft in flight? (Aerofoils)
- b) How can a scientist get rid of a cause and effect confusion? (Straight and Crooked Thinking)
- c) Unnatural slavery of man to man is despicable. Elaborate. (Freedom)

5. Complete the following sentences choosing the correct answers from bracket: [10×0.5=5]

- a) The building does not conform.....safety regulations.(with, to).
- b) He is steeped.....the literature of ancient Greece and Rome. (with, in).
- c) It is time they brought the cows in. Its passive voice is (It is time the cows were brought in / The cows were brought in time)
- d) Nobody has slept in that rooms for years. (That room has not been slept in for years / That room has not been used for sleeping purpose for years.)
- e) It.....if you had not caught it. (would break / would have broken)
- f) If it rained, I at home. (should stay / could stay)
- g) He jumped up as if he..... (were stung / had been stung)
- h) It seemed at least twenty minutes since Smith..... for the village. (set off / had set off)
- i) The crown and glory of life..... character. (is / are)
- j) The trouble with all those cars..... slow speed. (was / were)

6. Put the following information into APA and MLA styles of citation. [4]

Name of the book: The Atmosphere: An Introduction to Reference Meteorology

Author's name: Frederick Lutgens and Edward Tarbuck. /

Publisher: Pearson Publishing Company Limited

Date of publication: 2016

Publishing place: London

7. As a secretary of a local youth club, write a notice including 5 agendas for the 4th meeting of this fiscal year focusing on the issue of mental health of children during the COVID pandemic. [5]

8. Prepare a progress report of ongoing sports week at your college in a letter format addressing the coordinator of students' welfare committee. [6]

9. Write a report on advancement in the field of science and technology in Nepal in the last ten years to submit it to Ministry of Science and Technology, Singhadurbar, Kathmandu. Show only title page, introduction, discussion, conclusion and recommendation parts of the report. [10]

10. Use of plastic bags is one of the factors of environmental degradation. You have a grand plan to solve the problem. Write a proposal to the Ministry of Environment offering your plan. Prepare only problem, objective, methodology, and cost estimate of your proposal. [10]

11. Write, in about 500 words, a research article on "Impact and Challenges of COVID-19 Pandemic and the Role of Information Technology in Education." [10]

TRIBHUVAN UNIVERSITY
INSTITUTE OF ENGINEERING
Examination Control Division
2078 Bhadra

Exam.	Regular		
Level	BE	Full Marks	80
Programme	BEL, BEX, BCT, BAG	Pass Marks	32
Year / Part	III / I	Time	3 hrs.

Subject: - Communication English (SH 601)

- ✓ Candidates are required to give their answers in their own words as far as practicable.
- ✓ Attempt All questions.
- ✓ The figures in the margin indicate Full Marks.
- ✓ Assume suitable data if necessary.

1. Edit the following text: [5]

Dr Brigitte halford, a professor of linguistics at Freiburg University in German agree bilinguals tends to use language better as a whole she says. 'They also display greater creativity and problem-solving ability, and they learn further languages more easily.' So with all of the benefit, why do we not show more enthusiasm for learning other languages.

2. Read the following text carefully and interpret it so as to make the meaning clear. [5]

The history of civilization shows man always how has to choose between making the right and wrong use of discoveries of science. This has never been truer than in our own age. In a brief period, amazing discoveries have been made and applied to practical purposes. It has become a platitude to say – we are living in an age of revolution.

3. Read the following text carefully, prepare its notes and write a summary. [5+5]

Acupuncture is a system of treatment of disease which has been practiced in China for nearly 5000 years. It consists in the rapid insertion of fine steel needles, about six centimeters long, on particular spots on the body of the patient. After inserting the needle, the doctor twirls the needle between his thumb and forefinger. There are hundreds of acupuncture points on the body. When acupuncture is made on a spot on the body, energy flows from there along line known as meridians to the diseased organ. The flow of energy helps to restore the balance of the system and thus correct the disorder. The points of treatment may be far from the seat of the disease. For example, to cure a toothache, the acupuncturist may insert a needle on the palm of the patient.

Although China is considered to be the country where acupuncture originated, some forms of treatment resembling it has been reported from other parts of the world by anthropologists. Among some ancient tribes, stones and arrows were used to prick the skin. In another form of treatment, the skin on particular spot of the body was burnt to affect a cure for certain diseases. Whether these kinds of treatment can rightly be classed with acupuncture can be known only after further research.

For long acupuncture was dismissed by the west as a form of superstition like witchcraft and magic cure. Even in China admiration for the western system of medicine was so great that the native systems of treatment were neglected or mistrusted. Moreover, the theoretical basis of acupuncture that was propounded in China was a mixture of spirituality, philosophy and physiology. This stood in the way of its acceptance by Chinese scientists.

During the 1960s acupuncture came to the notice of western scientists, who viewed it with skepticism as well as curiosity. Doctors from Europe went to China to make a firsthand study of this strange form of treatment. They were convinced by what they saw that acupuncture worked. Not only were diseases cured, but even operations were

performed after administering anesthesia by acupuncture. The patient of such an operation could see and know what was being done, but felt no pain. After the operation, he could get up and walk away. Doctors in other parts of the world took acupuncture seriously and some of them trained themselves and set up practices in their countries. In China itself the status acupuncture rose when Chinaman Mao officially ranked acupuncturist with other physicians.

4. Answer any TWO of the following questions:

[2×5]

- a) What elements of science can the ordinary citizen use in order to help his society develop?
- b) Sketch the character of Dmitri Dmitritch Gurov in about 150 words.
- c) Russell says 'with the increase of knowledge and skill, wisdom becomes more necessary. 'Do you agree with him? Give your opinions.

5. Choose the best answer:

[10×0.5]

- a) Rapid technological progress does not create tension.....workers. (within, among)
- b) How can I give.....when I am not at fault. (in, up)
- c) A red and black horse grazing in the field. (is, are)
- d) Milton was one of the greatest poets that ever lived. (has, have)
- e) The passive voice of 'We have decided to open a new branch' is(To open a new branch has been decided by us / It has been decided to open a new branch)
- f) The passive voice 'I don't like people telling me what to do' is.....(I don't like being told what to do / I do not like being told by the people)
- g) He walks as if helame. (was / were)
- h) It's time we our work. (started / start)
- i) If I were an orange, I spherical and juicy. (shall be / should be)
- j) Unless she there on time, they would have selected someone else. (reached / had reached)

6. Put the following information into APA and MLA style of citation:

[4]

- a) Name of the author: Harris, Rob.
- b) Title of the article: Clinton on Climate Change.
- c) Name of the newspaper: The New York Times
- d) Date: 17 May 2007
- e) Page number: 20-21

7. Imagine that you are a secretary of a local social club. The third meeting of your club was held on 10th January 2020. Write the minutes of the meeting concerning any five agenda discussed in the meeting.

[5]

8. Suppose that you are invited to submit a proposal an establishing a paper factory in the remote area of Gorkha district. Show the title page, abstract, statement of the problem, objectives and conclusion parts of your proposal.

[10]

9. Imagine that you have undertaken the project on the construction of hydro-electricity supply centre at a remote village in your district and the work is going on. Write a second quarterly program report in memo format.

[6]

10. Imagine that you are the chairman of a newly formed committee for studying the causes of road accidents in the highways of Nepal. Prepare title page, acknowledgements, table of contents and abstract of the report which you are going to submit.

[10]

11. Imagine that you have carried out a study on the causes of deforestation in the hilly regions of Nepal. Write title page, acknowledgement, abstract and recommendation parts of your report.

[10]

TRIBHUVAN UNIVERSITY
INSTITUTE OF ENGINEERING
Examination Control Division
2078 Kartik

Exam.	Back		
Level	BE	Full Marks	80
Programme	BEL, BEX, BCT, BAG	Pass Marks	32
Year / Part	III / I	Time	3 hrs.

Subject: - Communication English (SH 601)

- ✓ Candidates are required to give their answers in their own words as far as practicable.
- ✓ *Attempt All questions.*
- ✓ *The figures in the margin indicate Full Marks.*
- ✓ *Assume suitable data if necessary.*

1. Edit the following text.

[5]

I have no idea whether the right pronoun for God is He, She or It. But this I'm sure of. If god could somehow be induced to take that test, God will not come out macho and not feminism, either, but right at the middle. Fellow androgynes, its a nice thought.

2. Read the given passage and interpret it.

[5]

Learning style is not the only area undergoing demystification: our understanding of intelligence is also being reconstructed. The IQ score, developed early in the 20th century, is supposed to be a measure of a person's innate intelligence, with a score of 100 defined as normal, or average. The higher the score, the brighter the person. Some of us grew up in communities where IQ was barely mentioned. In many cases this lack of knowledge might have been a blessing. Others of us grew up with "IQ envy", in communities where IQ scores were a big part of our culture. Since the score is considered a fixed, permanent measure of intellect like a person's physical height, the scores engendered strong feelings. Friends who scored higher on an IQ test had a secret weapon, a mysteriously wonderful brain. But then our friend "genius" was stumped trying to unpack and plug in a toaster oven or got hopelessly lost trying to follow the simplest driving directions. We may have been equally puzzled when another friend, who scored horribly low on an IQ test, went on to fame and riches. What is this traditional assessment of intelligence supposed to mean?

3. Read the following text carefully, make notes and write a summary of it.

[5+5]

Coronavirus disease (COVID-19) is an infectious disease caused by a newly discovered coronavirus. Most people infected with the COVID-19 virus will experience mild to moderate respiratory illness and recover without requiring special treatment. Older people, and those with underlying medical problems like cardiovascular disease, diabetes, chronic respiratory disease and cancer are more likely to develop serious illness.

The best way to prevent and slow down transmission is to be well informed about the COVID-19 virus, the disease it causes and how it spreads. Protect yourself and others from infection by washing your hands or using an alcohol based rub frequently and not touching your face. The COVID-19 virus spreads primarily through droplets of saliva or discharge from the nose when an infected person coughs or sneezes, so it is important that you also practice respiratory etiquette (for example, by coughing into a flexed elbow)

If COVID-19 is spreading in your community, stay safe by taking some simple precautions, such as physical distancing, wearing a mask, keeping rooms well ventilated, avoiding crowds, cleaning your hands and coughing into a bent elbow or tissue.

4. Answer any two of the following questions: [2×5]

- a) "Some books are to be tasted, others to be swallowed, and some few to be chewed and digested." Elucidate the statement.
- b) What elements of science can the ordinary citizen use in order to help his society to develop?
- c) How do modern boilers function?

5. Choose the best answer: [10×0.5]

- a) Conductors and conductivitya good passage. (are, is)
- b) The philosopher and the statesman.....required. (are, is)
- c) He has worked here.....this time last year. (for, since)
- d) The land is covered.....snow. (on, by)
- e) I pondered.....the question that was asked to me. (about, over)
- f) The soldiers.....better if they had been given clear orders. (would have fought, would fight)
- g) If you were to buy a car, it.....you a lot of money. (would cost, costs)
- h) She acts as if she.....an actress. (is, were)
- i) He congratulated me for what.....(I did, I had done)
- j) He returned to Kathmandu.....two days. (in, after)

6. Document the following details in APA and MLA style. [2+2]

Anthology: Making Connections
Editor: Kenneth J. Pakenham
Edition: 2nd
Publisher: Cambridge University Press
Place: New Delhi
Date: 2009

7. Suppose you are the secretary of Investment Company located at Bhaktapur, and the CEO wants to have a meeting with all the concerned personnel of the company in order to discuss social distancing protocol and other precautions in the office to avoid all possible infection of COVID-19. Now write a notice along with a four-point agenda to call the meeting. [5]
8. Suppose you are the chief consultant of an internet connectivity project at your college and the work is going on, write the first monthly progress report in a memo format. [6]
9. Prepare a cover page, abstract and recommendations of a report on CTEVT programme and employment opportunity. [10]
10. Write a proposal on construction of auditorium hall in your college, prepare rationale, estimated budget and conclusion only. [10]
11. Write a research article on effectiveness of virtual learning for the students of engineering in about 500 words. [10]

TRIBHUVAN UNIVERSITY
INSTITUTE OF ENGINEERING
Examination Control Division
2076 Chaitra

Exam.	Regular		
Level	BE	Full Marks	80
Programme	BEL, BEX, BCT, BAG	Pass Marks	32
Year / Part	III / I	Time	3 hrs.

Subject: - Communication English (SH 601)

- ✓ Candidates are required to give their answers in their own words as far as practicable.
- ✓ Attempt All questions.
- ✓ The figures in the margin indicate Full Marks.
- ✓ Assume suitable data if necessary.

1. Edit the following text:

How you frightened me she said breathing hard still pale and overwhelmed. Oh how you frightened me. I am halfdead. Why have you come why.

[5]

2. Read the following text carefully and interpret its meaning.

Computers and the Internet have made a revolution in science and engineering. Studying computational models of reality can be cheaper and better than studying reality. Sometimes reality is impossible to measure or too steep to scale, and computational models are the only way to get any purchase on it. Those are the actual computer revolutions; the others are mostly potential and not real, locked up in awe-inspiring icebergs that just float around eliciting admiration and making trouble. The computer revolution is still frozen, latent, waiting to happen.

[5]

3. Read the following passage carefully, make notes and write a summary of it.

[5+5]

The critical period theory is consistent with a vast amount of data that has been accumulating for many years about patients suffering from aphasia, a loss of language abilities associated with brain damage from injury or disease. The data provide conclusive evidence that language is localized in the brain's left hemisphere. Seventy percent of adult patients with an injury to the left hemisphere suffer from some language disability. However, patients with injuries to the right hemisphere retain the ability to speak and understand language perfectly. Their problems lie elsewhere, in activities such as recognizing faces and patterns or finding their way from one place to another.

Evidence for the effects of cerebral lateralization on language learning also comes mainly from research with patients suffering from aphasia after a hemispherectomy, surgery to remove one hemisphere of the brain. Lenneberg (1967), in his own research and in the relevant medical literature, found that 97 percent of children undergoing this operation before the age of ten recovered their language abilities after some temporary aphasia and continued to acquire their first language. In those rare cases where the same type of surgery was performed on adults, however, all the patients were left with complete and permanent aphasia. From this research, it seems that a child's brain has a degree of flexibility that allows the right hemisphere, when necessary, to take over the functions of the left. After lateralization, this flexibility declines significantly, and adults who lose language through brain injuries are unable to regain it. On the basis of these research findings, proponents of the critical period theory claim that it is this lack of flexibility in adults that limits their ability to acquire native-speaker pronunciation in a second language.

4. Answer any TWO of the following questions. [2×5]

- a) What is unnatural slavery according to Shaw? [Of Studies]
- b) What is the difference between impartiality and wisdom? [Knowledge and Wisdom]
- c) An ideal family always grants the space for hope of life in every difficult. Elucidate it with reference to the text 'Civil peace'. [Civil peace]

5. Choose the correct words from the brackets. [10×0.5]

- a) If he should wake up, I to him (talk, will talk)
- b) If you throw a stone into water, it(sinks, will sink)
- c) The letter, together with some applications,.....lost yesterday. (was, were)
- d) Message after message..... sent to her. (have been, has been)
- e) Each of them.....happy. (were, was)
- f) He has no adherence.....old system of rituals in marriage. (for, to)
- g) She is accomplished.....music. (in, into)
- h) They thanked me for what I.....(did, had done)
- i) Shanti.....for me when I arrived. (had waited, was waiting)
- j) The passive voice of 'He let her to play' is.....(He is let to play, He was allowed to play)

6. Write the following bibliographic information first in MLA and then in APA. [4]

Name of editors: Edwin D. Reilly, Anthony Ralston, and David Hemmendinger
Name of book: Encyclopedia of Computer Science
Edition: 4th
Year of publication: 2003
Name of publisher: Wiley
Place of publication: Chichester, UK

7. On behalf of the secretary of Engineering Association, write a notice for meeting along with agenda to be sent to the members of this association. [5]

8. Assume that you are requested to write a proposal on establishing an engineering college in your local town. Write a proposal to the concerned local authority including only abstract, objectives, rationale and methodology. [10]

9. Suppose you have recently participated in a one-day seminar on Vocational Education. Write a report to the Director of National Institute of Vocational Education, Putalisadak, Kathmandu. Prepare it in memo format. [6]

10. Write a report, to be submitted to the Ministry of Information and Communications, on development of information technology in Nepal in the last five years. Show only the title page, introduction, conclusion recommendations parts of the report. Also, write an outline of your report. [10]

11. Write a brief research article on the role of transportation in the development of tourism in Nepal. [10]

TRIBHUVAN UNIVERSITY
INSTITUTE OF ENGINEERING
Examination Control Division
2076 Ashwin

Exam.	Back		
	Level	BE	Full Marks
Programme	BEL, BEX, BCT, BAG	Pass Marks	32
Year / Part	III / I	Time	3 hrs.

Subject: - Communication English (SH 601)

- ✓ Candidates are required to give their answers in their own words as far as practicable.
- ✓ Attempt All questions.
- ✓ The figures in the margin indicate Full Marks.
- ✓ Assume suitable data if necessary.

1. Edit the following text. [5]

Who is knocking? whispered his wife lying beside him on the floor. I do not know he whispered back breathlessly the second knocking was so loud that the rickety old door could have fallen down.

2. Read the following text and interpret its meaning in your own language: [5]

If we observe the actions of man, whether as individuals or as groups, and whether scientists or non-scientists, we find that they frequently fall into avoidable errors because of a failure to reason correctly. There are many reasons for this, though only a few can be dealt with here.

The first difficulty is bound up with (related to) the use of words. It frequently happens that what one person means when he uses a certain word is different from what others mean. Consider, for example, the words intelligence, oxygen, accurate and average. In intelligence, we face the problem that a word may not mean only one thing, but many in this instance a very complicated set of aptitudes and abilities whose numbers and characteristics are not agreed upon by the specialists who study the phenomenon, and are even less understood by the layman (non specialist). In oxygen, we have a different problem, for although both; a research chemist and a chemical manufacturer identify the word theoretically with the element O, in practice they have different concepts about it. Thus, if the researcher performed a delicate experiment, using the manufacturer's oxygen, it might easily be a failure since the so-called O, whether used as a solid, liquid, or gas, would almost certainly contain other substances. Hence, another difficulty about words is that they often do not differentiate clearly enough between several varieties of the 'same' thing.

3. Read the following text carefully, make it note and write a summary. [5+5]

Plagiarism is the use of other person's ideas and expressions in your writing without acknowledge the source. The word comes from the Latin word 'plagiaries' and Alexander Lindey defines it as "the false assumption of authorship: the wrongful act of tacking the product of another person's mind and presenting it as one's own". In short, to plagiarize is to give impression that you have written or thought something that you have in fact borrowed from someone else, and to do so is considered a violation of the personal responsibility to acknowledge "academic debts".

The most blatant form of plagiarism is reproducing someone else's sentences, more or less verbatim, and presenting them as your own. Other forms include repeating another's particularly apt phrase without appropriate acknowledgement, paraphrasing someone else's argument as your own, introducing another's line of thinking as your own development of an idea, and failing to cite the source for a borrowed thesis or approach. Plagiarism falls outside the scope of copyright infringement. Copyright infringement, in

contrast, is using the work of a copyrighted work beyond the limit of fair use without the permission of the owner of copyright law are not plagiarism. The penalties of plagiarism can be severe, ranging from loss of respect to loss of degrees, tenure or even employment. At all stages research and writing, you must guard against the possibilities of inadvertent plagiarism by keeping careful notes that distinguish between your own musings and thoughts and material you gather from others.

Even without considering the penalties of plagiarism, the best scholars generously acknowledge their debts to others. By doing so they not only contribute to the historiography of scholarship but also help younger scholars understand the process of research and discovery.

4. Answer any two of the following questions: [2x5]
- What is the conflict in the mother's mind and how did she resolve it? (The Mother of a Traitor)
 - "Einstein was the greatest genius of the 20th century." Explain it. (What Einstein Did)
 - Why do people make avoidable errors, and what sort of people makes them? (Straight and Crooked Thinking)
5. Choose the correct words from the brackets: [0.5x10]
- Many a flower born to blush unseen. (is, are)
 - Every boy and every girl given sweets. (was, were)
 - He is absent the class. (from, in)
 - Steel is made iron. (of, from)
 - I saw him the race. (win, to win)
 - If he comes to me, I him. (help, would help)
 - If one buys a car, it money. (cost, costs)
 - I should be (listened at, listened to)
 - He, along with his teachers, playing. (is, are)
 - The principal and accountant on leave. (is, are)
6. Arrange the following information into APA and MLA style of citation: [4]
- Name of the book: Solar energy
 - Date of publication: 1996
 - Place of publication: U.K.
 - Publisher's name: Prentice Hall
 - Name of the author: Hughes, A.
7. Inventing necessary details, write a notice with four point agenda for the forth coming fifth meeting of your local social club. [5]
8. As a Chief Consultant of Micro hydro-power project in the remote area of Dhading district, write the third monthly progress report in a memo format. [6]
9. Write a report to be submitted to the Chief Engineer, Department of Roads, on controlling the sound pollution of the Kathmandu Valley. Prepare only the Title page, Abstract, Conclusion and recommendation parts of the report. [10]
10. Suppose that you are invited to submit a proposal on establishing a paper factory in Nepal. Show the title page, abstract, objectives and conclusion parts of your proposal. [10]
11. Write a brief research article on the importance of English for the technical student. [10]

TRIBHUVAN UNIVERSITY
 INSTITUTE OF ENGINEERING
Examination Control Division
 2075 Chaitra

Exam.	Regular / Back		
Level	BE	Full Marks	80
Programme	BEL, BEX, BCT, BAG	Pass Marks	32
Year / Part	III / I	Time	3 hrs.

Subject: - Communication English (SH 601)

- ✓ Candidates are required to give their answers in their own words as far as practicable.
- ✓ Attempt All questions.
- ✓ The figures in the margin indicate Full Marks.
- ✓ Assume suitable data if necessary.

1. Edit the following text: [5]
 'aboard again monna marianna? take care you may be kill and nobody bother search for the culprit...

2. Read the following text carefully and interpret it so as to make the meaning clear. [5]
 By teaching all other subjects, except values, we may produce great scientists, engineers, doctors, scholars, management experts, literatures etc. comparable with the best anywhere in the world but if the great professionals do not have peace of mind and qualities of love and kindness, what kind of society will we have?

3. Read the text given below carefully, make notes and write summary of it: [5+5]
 When fission occurs, an average of 2-5 neutrons are emitted from the nucleus. If the fission process can be so arranged that one of these liberated neutrons is captured by another U-235 nucleus to produce another fission, then the reaction will become self-sustaining.
 When emitted, neutrons travel at a high velocity, and it is known that such fast neutrons have little chance of being captured by fissile Uranium. However, if slowed down to thermal speeds, their probability of capture is greatly increased. In the normal thermal reactor, the uranium is surrounded by a large mass of moderating material. The liberated neutrons collide repeatedly with the light atoms of the moderator in such a way that they lose much of their energy and eventually become thermalised. The moderator may be either a liquid such as heavy water, or a solid such as graphite. Both these substances are of low atomic weight and have low neutron absorption cross-sections. With the graphite moderator, the uranium which is generally in the form of rods is inserted into channels cut out of the graphite. These channels are so arranged as to form a lattice structure, the object of which is to reduce neutron escape to a minimum. Provided that a sufficient mass of uranium is disposed in a number of rods through the moderator, a high enough proportion of the emitted neutrons will find their way to fissile nuclei to produce a chain reaction. The minimum quantity of uranium required to initiate the chain reaction is called the critical mass.

4. Answer **any two** of the following questions: [2x5]
 - a) What do you mean by 'a sense of proportion'? (Knowledge and Wisdom)
 - b) Why did the mother kill her own son? (The Mother of a Traitor)
 - c) Describe Pahom's growing greed for land. (How Much Land Does a Man Need?)

5. Choose the best answer: [0.5x10]
 - a) No sooner had he reached the station than the train(had left, left).

- b) He liked books that moral lessons. (gave, gives)
- c) He, as well as they, coming to the party. (is, are)
- d) More books than one missing. (are, is)
- e) The project will be over next Monday. (before, within)
- f) She came back to Kathmandu two days. (in, after)
- g) Be careful, or else you those plates. (drop, will drop)
- h) The passive voice of "Who did it" is (By whom was it done?, Who is it done by)
- i) The project is running financial difficulties. (with, into)
- j) Had I been there, I every part of the city. (had visited, would have visited)
6. Put the following information into APA and MLA styles of citation. [4]
 Author's name - Bernstein, T.M. & Often, S.B.
 Year of publication - 1964
 Title - The Careful Writer
 Place of publication - New York
 Publisher - Atheneum
7. Suppose you are the secretary of a local sports club. Write the minutes of the fifth meeting held recently inventing at least four agenda. [5]
8. Suppose you are the chief consultant of a urban internet connectivity project and the work is going on in your local town. Write a first quarterly progress report in memo format. [6]
9. Write a research article on the causes and consequences of noise pollution in the urban settlements in Nepal. [10]
10. Write a proposal on the maintenance and upgrading of Dhulikhe-Bahrabise section of Arniko Highway including abstract, statement of problem and lost estimate parts only. [10]
11. The Ministry of Road and Transport is concerned about the rapid increase in the number of road accidents on the highways. As a newly formed commission chairman, write introduction, discussion and conclusion parts of your report investigating causes of the road accidents in your local town. [10]

Exam.	Back		
Level	BE	Full Marks	80
Programme	BEL, BEX, BCT, B.Agr.	Pass Marks	32
Year / Part	III / I	Time	3 hrs.

Subject: - Communication English (SH601)

- ✓ Candidates are required to give their answers in their own words as far as practicable.
- ✓ Attempt All questions.
- ✓ The figures in the margin indicate Full Marks.
- ✓ Assume suitable data if necessary.

1. Edit the following text.

[5]

A board game is a game played with counters or pieces that are placed or removed from or moved across a board simple board games often make ideal family entertainment. Since they are often appropriate for all ages. Some board games such like chess and Chinese checkers have strategic value and have been classic for centuries.

2. Read the given text and interpret its meaning.

[5]

By teaching all other subjects, except moral values we may produce great scientists, engineers, doctors, scholars, management experts, litterateurs etc. comparable with the best anywhere in the world but if these great professionals do not have peace of mind and qualities of love and kindness, what kind of society will we have?

3. Read the following passage carefully and make notes and write a summary of it.

[5+5]

Is classical music any way related to popular music? That is a controversial question. Advocates of classical music claim that it constitutes are and that pop music is only light entertainment. But, that is not always true. Some people have only elevated classical music to that special status by arguing that the works are more complex because of the range of notes involved. However, jazz, rap and many other forms of popular music sometimes do make use of a number of notes that are as complex as classical music. It is also argued that classical music songs are longer, sometimes extending to thirty minutes or more. Popular music songs are shorter and more repetitive so that they can be remembered for people to play or to sing.

Every language has its own popular music, like it has its own classical music. Indian popular music often known as Indi-pop or Hindi pop is a form of pop music in India. It is a fusion of various Indian folk and classical music styles and is also influenced by modern beats from different parts of the world. The major push given to Indi-pop was from Pakistani singer, Nazia Hassan. Indian pop has taken another interesting turn with the "remixing" of old Indian film songs-an attempt to make them sound more modern by adding new beats. These remixes have become very popular among the younger generation; they give the old melodies new life and vigour. The purists among the older generation however maintain that the beauty of the song is lost!

4. Answer any two of the following questions.

[2×5]

- a) On what two aspects of science does the development of our world depend? (The Scientific Attitude)
- b) What lessons can we learn from the story "The Mother of a Traitor"?
- c) Even the best technicians should also be good citizens? Do you agree? Why?

5. Rewrite the following sentences using the correct alternative from the brackets. [0.5×10]

- a) It's time the plane _____ (to land, is landing, landed).
- b) The stream and the farm _____ a good view. (offer, offers).
- c) Some furniture _____ to be ordered for the room. (have, has).
- d) If I _____ to choose one I'd go for the green (was, were)
- e) Anybody _____ this if you had not done. (will have done, may have done, would have done)
- f) "I guess people are watching us", really? But I don't think we _____ (will be watched, were being watched, are being watched)
- g) Do you remember what Priya _____ before she got her article published? (did, had done, would do)
- h) By the start of the next century, I think people _____ in the Mars. (have settled, can settle, will have settled)
- i) This book has been translated _____ several languages. (to, by, into)
- j) Our teacher objects _____ anyone's coming late. (to, against, for)

6. Put the following information into APA and MLA style of citation. [4]

Name of the book	-	Awakening Spirituality
Author's name	-	Dr. Binny Sareen
Publisher	-	Brahma Kumaris, Literature Department
Publishing place	-	India
Year of Publication	-	2012

7. Inventing all necessary details, draft a notice with a three point agenda for the 15th meeting of a Local Sports Club. [5]
8. Suppose you are doing a project on view tower building construction. Write a report about the progress of the work you have completed so far. [6]
9. Imagine you are going to write a proposal on establishing a soap factory. Write the introduction, statement of problem and objective parts of the proposal. [10]
10. Prepare a research article on the role of technical colleges in the development of nation. [10]
11. Imagine you are doing a project on construction of a suspension bridge in a village. Write the first monthly report in a memo format. (Assume necessary data yourself.) [10]

Exam.	Regular		
Level	BE	Full Marks	80
Programme	BEL, BEX, BCT, B.Agr.	Pass Marks	32
Year / Part	III / I	Time	3 hrs.

Subject: - Communication English (SH601)

- ✓ Candidates are required to give their answers in their own words as far as practicable.
- ✓ Attempt **All** questions.
- ✓ The figures in the margin indicate **Full Marks**.
- ✓ Assume suitable data if necessary.

1. Edit the following text:

Your leader is my son she said and not one of the soldiers doubt it. They fell in beside her, singing his praises, saying how clever and brave he is, and she listen to them with head proudly raise, showing no surprise.

[5]

2. Read the following text carefully and interpret it so as to make the meaning clear.

[5]

The third great defect of our civilization is that it does not know what to do with its knowledge. Science has given us powers fit for the Gods, yet we use them like small children. For example, we do not know how to manage our machines. Machines were made to be man's servants; yet he has grown so dependent on them that they are in a fair way to become his masters. Already most men spend most of their lives looking after and waiting upon machines. And the machines are very stern masters. They must be fed with coal, and given petrol to drink, and oil to wash with, and they must be kept at the right temperature. And if they do not get their meals when they expect them, they grow sulky and refuse to work, or burst with rage, and blow up, and spread ruin and destruction all round them. So, we have to wait upon them very attentively and do all that we can to keep them in good temper. Already we find it difficult either to work or play without the machines, and a time may come when they will rule us altogether, just as we rule the animals.

3. Read the following passage carefully, make notes and write a summary.

[5+5]

Although religion does not inhibit the acquisition of wealth, although it does not hold up large fortunes as evil, the tenor of its teaching, by and large, is to induce an attitude of indifference to worldly things, things which gratify one's lower self and keep one engrossed in money-making. The students should be made to realize that the real goods of life are spiritual, love of things of the spirit and service of one's fellowmen, joy of an ordered disciplined life. These are blessings money cannot buy. What is wealth before such things of the spirit? Of all religious teachers Jesus Christ has dealt more comprehensively than any other with the problem of wealth in all its aspects. He may be called the greatest exponent of the science of wealth. With only four words "Blessed are ye poor!" he changed altogether the values which man attached to human existence and human happiness and acquisition and possession of wealth. Real bliss consisted, he taught, not in riches nor in anything else which the world regarded as prosperity or felicity, but in the joy and happiness derived from being at peace with one's fellowmen through perfect love and fellowship and selfless service and sacrifice.

The word "poor" on the lips of the Master had a spiritual significance - the poor so far as they were poor in spirit, humble before God, simple, God-fearing, teachable, faithful. It could surely not have been his intention to hold up destitution and privation as a blessing in itself. That would have turned life into a terrible ordeal and it would have been heartless to exhort the poor to believe that money was not necessary for one's sustenance or the joys and blessings of life. Even things of the spirit cannot be had without money.

Extreme poverty is as liable to lead to the stagnation and impoverishment of the soul as excessive wealth. Not outward poverty but inward spirit was what Jesus Christ desired and demanded. Every religion asks a man to regard his wealth as a trust. Giving in charity for the relief of the poor and public welfare is not merely an act of compassion, not merely a religious duty, but also an act of social justice. All the gospels of wealth are based on the fundamental concept that none can claim an absolute or inherent right to property. Everyone holds it in trust from God to promote the good mankind. All rights to private property are subject to this primary obligation to God and man.

4. Answer any TWO of the following questions. [2×5]
- How can science be misused? Explain. [Use and Misuse of Science]
 - How did Monna Marinna carry out her responsibilities as an ideal citizen and as an ideal mother? [The Mother of a Traitor]
 - Describe the contribution of Einstein to the modern scientific world?

OR

Why did Joseph wood Krutch call grass a "miracle"?
St. Peter said "all flesh is grass". Discuss.

5. Write a research article on 'The Effects of Air pollution in Kathmandu Valley'. [10]
6. Write the following bibliographic references first in MLA and then in APA. [4]
- Name of book: Computer Addiction A Study of Computer Dependency
Name of publisher: Taylor and Francis
Name of author: M.A. Shotton
City of publication: London
Year of publication: 1989
Name of country: England
7. Suppose you are the secretary of a construction Committee. The 3rd meeting of the committee was conducted a few days ago. Imagine four relevant agendas and prepare minutes of the meeting. [5]
8. Write down the elements of proposal, describe briefly. [5]
9. Suppose that you want to establish a new hydropower company or an IT company in Nepal, and that you have prepared a proposal for it. Now show the following parts of your proposal: [10]
- Technical section
 - Management section
 - Cost estimate
10. Suppose you are the chairman of a committee formed to investigate the access of internet to the students in your college. Write a report including title page, letter of transmittal, abstract and recommendation. [10]
11. Write the second monthly progress report on the project 'Construction of Micro-hydro power plant'. Invent necessary details. [6]

Exam.	BACK		
Level	BE	Full Marks	80
Programme	BEL, BEX, BCT, B. Agri.	Pass Marks	32
Year / Part	III / I	Time	3 hrs.

Subject: - Communication English (SH601)

- ✓ Candidates are required to give their answers in their own words as far as practicable.
- ✓ Attempt All questions.
- ✓ The figures in the margin indicate Full Marks.
- ✓ Assume suitable data if necessary.

1. Edit the following text.

[5]

But when the war is over, the country recedes from the consciousness and it is rarely even at the back of the mind. The question am I doing any good to the country doesn't occur to the mind; and even the question is what I am doing good or bad for the country occurs only rarely. A limited patriotism is better than none but it is not enough.

2. Read the given text and interpret its meaning.

[5]

Computers have solved many problems for us, but they create some problems too. Say, for example, that you are writing a novel. After you are done with your first draft you decide to change your heroine's name from Linda to Lydia. With a typewriter you would have to retype every page containing the heroine's name. With word processing software, on a computer, you press just a few keys and the computer takes care of all the work. But technology hasn't solved all our problems. While many of Shakespeare's original documents survive, it takes only misplaced keystrokes to wipe out your next masterpiece.

3. Read the following passage carefully, make notes and write a summary of it.

[5+5]

The dearth of natural resources on the Australian continent is a problem with which government officials there have long struggled. As long distance travel has become ever more important to the national economy. Tourism represents more than 10 percent of national export earnings annually, and in less developed regions such as the Western Territory, the percentage is much higher.

Unfortunately, this otherwise rosy prospect has one significant cloud on the horizon. In recent years, there has been a move towards returning some of the land to the Aboriginal people. As Western society and culture have flourished on Australian soil, tribal people have been forced ever farther inland in an attempt to maintain their traditional ways of living, a desire that the government has striven to respect.

One of the central beliefs of the Aboriginal religion is that certain natural formations have spiritual significance and must be treated accordingly. Strict guidelines determine who may visit these sites and at what times. Unfortunately, many of these sites are the very natural wonders tourists flock to see. If non-Aboriginal people are forbidden to visit these natural wonders, many may choose not to vacation in a region that sorely needs the income generated by tourism.

The Australian government has dealt with this dilemma thus far by trying to support both sides. The Aboriginal council is still trying to put an end to such use of certain sites, however, and it remains to be seen whether respect for tradition or economic desires will ultimately triumph.

4. Answer any TWO of the following questions:

[5x2]

- a. Why do people make avoidable errors? And what sorts of people make them? (Straight and Crooked Thinking)
- b. How do modern boilers function? (Steam Boilers)
- c. "Studies serve for delight, for ornament and for ability". Explain it. (Of Studies)

5. Choose the best answer.

[0.5x10]

- a. The passive voice of 'I let him go' is (He was let go/ He was let to go)
- b. The passive voice of 'They saw the cat stealing the meat' is (The cat was seen stealing the meat/The cat was seen to be stealing the meat)
- c. When he became rich, he threw all his old friends. (off, over)
- d. The project is running financial difficulties. (in, into)
- e. What you think and dopraiseworthy. (is, are)
- f. Letter after letterbeen sent to her. (has, have)
- g. If I to ask you, would you help me? (was, were)
- h.that happen, I will quit the job. (should, if)
- i. Note down my address lest you (should forget, might forget)
- j. It a week since I saw Jill. (has been, is)

6. Write the following bibliographic information first in MLA and then in APA.

[4]

Name of newspaper: New York Times

Title of article: Messi Is Barcelona's Boy Genius

Name of writer: Eduardo Galeano

Section and page number: N1

Date of publication: 22 May 2011

7. Assume that you have recently taken over as the secretary of a public limited company. Informal discussion with the senior officers reveals that the growth of the organization has been hampered because of frequent strikes by the workers. After going through your preliminary report the chairman has decided to call a meeting of the Board of Directors to discuss the issue in depth and to find a lasting solution to the problem. Draft a notice along with four-point agenda for the meeting. [5]

8. Suppose that you are chief engineer working on a five-year your engineering field, which began last year. Write the first quarterly progress report of the project. [6]

9. Imagine that you are requested to submit a proposal for establishing a sophisticated computer lab in one of the technical companies. Write title page, technical section and cost estimate of the proposal that you are going to submit. [10]

10. Prepare abstract, introduction and recommendations of a report on "Damage and Loss of Life due to Flood in Different Parts of Nepal". [10]

11. Write, in about 500 words, a research article on "Role of Engineers in Nation-building Campaign". [10]

Exam.	Regular		
Level	BE	Full Marks	80
Programme	BEL, BEX, BCT B. Agri.	Pass Marks	32
Year / Part	III / I	Time	3 hrs.

Subject: - Communication English (SH601)

- ✓ Candidates are required to give their answers in their own words as far as practicable.
- ✓ Attempt All questions.
- ✓ The figures in the margin indicate Full Marks.
- ✓ Assume suitable data if necessary.

1. Edit the following text.

[5]

Some argue that american politics has become so polarized that politicians will argue merely to gain power, and the subject to debate is often negligible. The vigorous dispute over where to place a comma in the republican platform for example was motivated not by any significance change of meaning but a desire not to show any deference of the other side.

2. Read the given text and interpret its meaning.

[5]

The survival of the publishing industry depends upon the existence of a public who will buy the printed word in the form of newspapers, books and magazines. Over the past several years, however, the advance of electronic media, particularly CD-ROMs, online computer services, and the Internet, has made information available to the public electronically without the need for printed materials. As the availability of electronic media increases and as it is more easily accessible, the public has less need for printed materials.

3. Read the following passage carefully, make notes and write a summary of it.

[5+5]

According to usage and conventions which are at last being questioned but have by no means been overcome, the social presence of a woman is different in kind from that of a man. A man's presence is dependent upon the promise of power which he embodies. If the promise is large and credible, his presence is striking. If it is small or incredible, he is found to have little presence. The promised power may be moral, physical, temperamental, economic, social, and sexual—but its object is always exterior to the man. A man's presence suggests what he is capable of doing to you or for you. His presence may be fabricated, in the sense that he pretends to be capable of what he is not. But the pretence is always toward a power which he exercises on others.

By contrast, a woman's presence expresses her own attitude to herself, and defines what can and cannot be done to her. Her presence is manifest in her gestures, voices, opinions, expressions, clothes, chosen surroundings, taste—indeed there is nothing she can do which does not contribute to her presence. Presence for a woman is so intrinsic to her person that men tend to think of it as an almost physical emanation, a kind of heat or smell or aura.

To be born a woman has been to be born, within an allotted and confined space, into the keeping of men. The social presence of women has developed as a result of their ingenuity in living under such tutelage within such a limited space. But this has been at the cost of a woman's self being split into two. A woman must continually watch herself. Whilst she is walking across a room or whilst she is weeping at the death of her father, she can scarcely avoid envisaging herself walking or weeping. From earliest childhood she has been taught and persuaded to survey herself continually.

4. Answer any TWO of the following questions:

[5x2]

- a) What elements of science can the ordinary citizen use in order to help his society develop? (The Scientific Attitude)
- b) Write the character of Dmitri Dmitritch Gurov in about 150 words. (The Lady with the Pet Dog)
- c) Russell says 'with the increase of knowledge and skill, wisdom becomes more necessary'. Do you agree with him? Give your opinions. (Knowledge and Wisdom)

5. Choose the best answer:

[0.5x10]

- a) You, he and I _____ neighbours. (am, are)
- b) The team _____ struggling for its victory. (is, are)
- c) It is me who always _____ right decision. (take, takes)
- d) He _____ as if he were illiterate. (talks, talked)
- e) Had she reached airport in time, she _____ her flight. (wouldn't miss, wouldn't have missed)
- f) If you buy this car, you _____ Rs. 25,00000/- only. (will have to pay, have to pay)
- g) There's no one here I can confide _____ (in, on)
- h) The king bestowed an honour _____ her. (to, upon)
- i) The passive voice of "His conduct shocked me" is _____. (I was shocked by his conduct / I was shocked at his conduct)
- j) The passive voice of "He urged the council to reduce the rates" is _____. (He urged that the rates should be reduced / He urged the rates to be reduced)

6. Change the following citations as indicated in brackets:

[4]

- a) Lyons, J. Language and Linguistics. USA: CUP, 2003. (into APA)
- b) Imam, S.T. Brush UP Your English. India: Bharati Bhavan, 2003. (into APA)
- c) Hall, Dauglas. (1989). Digital circuits and systems. New York: Macmillan. (into MLA)
- d) Wolf, Daniel. (1995). Lives of notable gay men and lesbians. New York: Chelsea Publishing. (into MLA)

7. Suppose you are the newly appointed chairperson of the committee of the 14th National Technological Festival 2017. In order to make the festival highly effective and successful, you want to discuss some matters with other members of the committee. Now write a notice along with four-point agenda for the first meeting of the committee.

[5]

8. Suppose you are senior engineer working on Electoral Supply Project, Kathmandu, Nepal. Write its first yearly progress report that you are going to submit to the project manager. Prepare it in letter format.

[6]

9. Assume that as a Project Development Officer you have been asked by the National Institute of Computer Education, Kathmandu, to set up a Communication Technology Centre at Dhobighat, Kathmandu for training professionals in the use of latest technological aids for face-to-face and distance communication. Write a technical proposal to be submitted to the Director of the Institute. Prepare only title page, technical section and cost estimate of your proposal.

[10]

10. There has been minimum rainfall in winter in Kathmandu this year. Write a report on the problems caused by it to the Kathmanduits. Prepare an outline of your report and then write cover page, abstract and introduction in detail.

[10]

11. Write, in about 500 words, a research article on "Significance of power-point presentation in technical communication".

[10]

Examination Control Division
2073 Shrawan

Exam.	New Back (2066 & Later Batch)		
Level	BE	Full Marks	80
Programme	BEL, BEX, BCT, B. Agri.	Pass Marks	32
Year / Part	III / I	Time	3 hrs.

Subject: - Communication English (SH601)

- ✓ Candidates are required to give their answers in their own words as far as practicable.
- ✓ Attempt **All** questions.
- ✓ The figures in the margin indicate **Full Marks**.
- ✓ Assume suitable data if necessary.

1. Edit the following text:

[5]

Arundhati Roy the famous novelist and activist who won the booker prize in 1997 for her novel. The God of small things was born in shellong Meghalaya on november 24, 1961 to a Keralite mother and a Bengali father.

In 1984 Arundati began a brief career in films. She played the role of a village girl in the moule massey sahib and also wrote the screen play for the film in which Annie gives in those ones.

Roy began writing the god of small thengs in 1992 and finished it in 1996.

2. Read the following text carefully and interpret it so as to make the meaning clear.

[5]

Ever since humans have inhabited the earth, they have made use of various forms of communication. Generally, this expression of thoughts and feelings has been in the form of oral speech. When there is a language barrier, communication is accomplished through sign language in which motions stand for letters, words, and ideas. Tourists, the deaf, and the mute have had to resort to this form of expression. Many of these symbols of whole words are very picturesque and exact and can be used internationally; spelling, however, cannot.

3. Read the following passage carefully and (i) make notes and (ii) write summary.

[5+5]

To solve the most urgent health problems of developing countries, expert have recommended that priority should be given to primary health care. This approach to health care, as we have seen, emphasizes health maintenance through disease prevention and control. Many of the developing world's deadliest disease The experts point out; can be prevented if clean water and adequate sanitation are provided. Other disease can be prevented by mass vaccination programs. Still other can be controlled by effective health education that gives people information about ways to avoid malaria-carrying mosquitoes or about the importance of nutrition, especially for pregnant women and young children.

Primary heath care, as we have seen, does not merely focus on prevention and ignore the treatment of disease. Another priority for poorer nations is to provide timely diagnose and basic treatment for the general populations instead of technologically advanced and expensive treatment for a few wealthy people. Under international program, the governments of developing countries are given incentives to build community health centers and train health workers. Patients receive immediate attention from doctors, nurses and health workers who have to the necessary diagnostic training and equipment and have an adequate supply of drugs. These local health centers are much more accessible to people who need treatment than a few hospitals in the larger cities.

If poorer countries can offer this type of health care, the health of their general populations will improve rapidly. A number of developing countries have already shown that primary health care programs can be successful. Cuba eliminated polio in 1972, even before the disease was eliminated in the United States. In 1974, the World Health Organization began a program to immunize the world's children against six vaccine-preventable diseases during their first year of life. By 1994, the vaccinations were protecting 80 percent of children and the annual number of child deaths had fallen by 3 million. Another WHO program, whose goal was to wipe out polio in the Americas, began in 1985. The goal was achieved in 1991. In the year, nearly 2 million children in Peru were vaccinated in one week after polio had been diagnosed in a two-year-old boy. The boy, Luis Fermin, recovered and proved to be the last case of polio in the Americas.

4. Answer any two: [5×2]
- i) What was the mother's dilemma and how did she solve it? (The mother of A Traitor by Maxim Gorku)
 - ii) What do you mean by a sense of proportion? (Knowledge and Wisdom)
 - iii) Describe the contribution of Einstein to the world? (What Einstein did?)
5. Choose the correct words from the bracket: [0.5×10]
- i) Neither he nor his relative turned up. (has, have)
 - ii) Either sugar or tea suitable for the drink. (is, are)
 - iii) He asked me what I do for a living. (will, should)
 - iv) She has a taste music (of, for)
 - v) He was told not to worry the matter. (with, about)
 - vi) It is no use to come now. He is very busy. (to ask him, if you asked him)
 - vii) He was an scientist. (remote, imminent)
 - viii) A fool's paradise means (to have happy dreams, live in illusions)
 - ix) She yelled him. (to, at)
 - x) The news false. (is, are)
6. Write the following bibliographic references first in MLA and then in APA. [4]
- Name of the book: The Remains of the Day
 Name of the publisher: Faber
 Place of publication: London
 Year of publication: 1989
 Name of the author: Kazuo Ishiguro
7. As the C.R (class representative) of your class, write the Notice, Agenda and Minutes of the meeting: "Farewell programme for the seniors". [5]
8. Suppose you have been working on a project of your engineering field for a few months. Write the second monthly progress report of the work you have completed in letter format. [6]
9. Write a brief research article on reducing Air Pollution in the Kathmandu Valley. [10]
10. Suppose that you are interested in establishing a new software company in Kathmandu. Write title page, introduction and technical section of your proposal that you are going to submit to the Ministry of Science and Technology, Singha Durbar, Kathmandu. [10]
11. Write a report on "Development of communication system" in remote areas of Nepal. Invent necessary details. [10]

Exam.	Regular		
Level	BE	Full Marks	80
Programme	BEL, BEX, BCT B. Agri.	Pass Marks	32
Year / Part	III / I	Time	3 hrs.

Subject: - Communication English (SH601)

- ✓ Candidates are required to give their answers in their own words as far as practicable.
- ✓ Attempt All questions.
- ✓ The figures in the margin indicate Full Marks.
- ✓ Assume suitable data if necessary.

1. Edit the following text: [5]

But the Bengali lady with green who kept darting looks at the drummer rather than on the beautiful sitar player whispered suddenly he keeps staring at me Minakshi. Or, perhaps it is I who keep staring at him. I cant take my eyes off him Minakshi.

2. Give the interpretation of the following text: [5]

It is not only in public ways, but in private life equally, that wisdom is needed. It is needed in the choice of ends to be pursued and in emancipation from personal prejudice. Even an end which it would be noble to pursue if it were attainable may be pursued unwisely if it is inherently impossible of achievement. Many men in past ages devoted their lives to a search for the philosopher's stone and the elixir of life. No doubt, if they could have found them, they would have conferred great benefits upon mankind, but as it was, their lives were wasted.

I think the essence of wisdom is emancipation, as far as possible, from the tyranny of the here and the now. We cannot help the egoism of our senses. Sight and sound and touch are bound up with our own bodies and cannot be made impersonal. Our emotions start similarly from ourselves. An infant feels hunger or discomfort, and is unaffected except by his own physical condition. Gradually with the years his horizon widens and in a proportion as his thoughts and feelings become less personal and less concerned with his own physical states, he achieves growing wisdom. This is of course a matter of degree. No one can view the world with complete impartiality; and if anyone could, he would hardly be able to remain alive. But, it is possible to make a continual approach towards impartiality, on the one hand, by knowing things somewhat remote in time or space and, on the other hand, by giving to such things their due weight in our feelings. It is this approach towards impartiality that constitutes growth in wisdom.

Can wisdom in this sense be taught? And, if it can, should the teaching of it be one of the aims of education? I should answer both these question in the affirmative.

3. Read the following passage carefully, make notes and write a summary of it.

[5+5]

A recent investigation by scientists at the U.S. Geological Survey shows that strange animal behaviour might help predict earthquakes. Investigators found such occurrences within a ten-kilometre radius of the epicentre of a fairly recent quake. Some birds screeched and flew about wildly; dogs yelped and ran around uncontrollably.

Scientists believe that animals can perceive environmental changes several hours or even days before the mishap. Animals were noted as being restless for several weeks before a Tashkent, Uzbekistan, earthquake. An hour before the disaster, domestic animals refused to go indoors, and dogs howled and barked furiously. In 1960, an earthquake struck Agadir in Morocco. Survivors recall that stray animals, including dogs, were seen streaming out of town before the earthquake. In a safari zoo near San Francisco, llamas would not eat the evening before a 1979 quake, and they ran around wildly all night.

Unusual animal behaviour preceding earthquakes has been noted for centuries. British Admiral Robert Fitzroy reported huge flocks of screaming seabirds over Concepcion, Chile, in 1835. An hour and a half later, dogs were seen fleeing, and ten minutes later the town was destroyed. Similar stories of chickens running around in apparent states of panic, horses trembling, and dogs barking incessantly were recorded throughout the eighteenth and nineteenth centuries by survivors of earthquake destruction in India, Yugoslavia, Peru, Mexico, and the United States.

In 1976, after monitoring bizarre animal behaviour, the Chinese predicted a devastating earthquake. Although hundreds of thousands of people were killed, the government was able to evacuate millions of other people and thus keep the death toll at a lower level.

4. Answer any TWO of the following question:

[2×5]

- a. 'Is it she?' 'It is she?' What does this exchange tell us about what the people thought of her? What did they do when they saw her? Why? (The Mother of a Traitor)
- b. What are the two ways in which science can help society to develop? (The Scientific Attitude)
- c. What is chain reaction? Describe it in brief. (Chain Reaction)

5. Choose the best answer:

[0.5×10]

- a. Should you do it, Ihappy. (will be, would be)
- b. If she you, she would write an application. (was, were)
- c. He hates partinghis money. (with, from)
- d. The firm have provided mea car. (with, no preposition)
- e. The Passive Voice of 'Hear him now' is (Let him be heard now/He should be heard now)
- f. The Active Voice of 'Who was helped by whom?' is? (Who did help whom/Who helped whom)
- g. More than one student playing. (is, are)
- h. The Prime Minister and Chancellor coming. (is, are)
- i. It's time you those trousers. (wash, washed)
- j. I wish I meet her. (should, would)

6. Put the following information in to APA and MLA styles of citation. [4]

a) Book Name = The ACS style Guide: A manual for Authors and Editors

Author's name = Janet S. Dodd

Publishers = American Chemical Society

Place of Publication = Washington, DC

Year of Publication = 1986

b) Journal = Computer Publishing

Author = Jan V. White

Article = Colour in Context

Date of Publication = February, 1991

Page nos = 55-57

7. Suppose you are the secretary of Sony Electronics Private Limited, Baluwatar, Kathmandu and the 7th meeting regarding the problems of the staff of the limited has been held recently. Inventing the most relevant agenda, write minutes of the same. [5]

8. As a chief contractor of an affordable, earthquake resistant housing project, write the second quarterly progress report in memo format, invent necessary details. [6]

9. Write in about 500 words, a research articles on "Development of Information Technology in Nepal". [10]

10. Design the title page and write the Abstract, Table-of-Contents and Recommendation for the proposal titled "Building of an Auditorium" in your campus. [10]

OR

"Formation of A Student Project Club".

11. Imagine that you have already prepared a report on "Environmental Pollutions in Asia". Show the Title page, Abstract, Introduction and Recommendation sections of your report. [10]

Exam.	New Back (2066 & Later Batch)		
Level	BE	Full Marks	80
Programme	BEL, BEX, BCT, B.Agr.	Pass Marks	32
Year / Part	III / I	Time	3 hrs.

Subject: - Communication English (SH601)

- ✓ Candidates are required to give their answers in their own words as far as practicable.
- ✓ Attempt All questions.
- ✓ The figures in the margin indicate Full Marks.
- ✓ Assume suitable data if necessary.

1. Study the following paragraph carefully and edit it: [5]

Again, you have to watch at the interviewer when he she speaks to you. In some interviews, the interviewer may shake hands with you. Warm firm grip of the hand suggests confidence and friendliness. Eye-contact is necessary at the interview. Fidgeting with your pen may suggest nervousness. So it is better to put your hands on your lap.

2. Read the following text carefully and interpret it so as to make the meaning clear: [5]

Read not to contradict and confute, nor to believe and take for granted, nor to find talk and discourse; but to weigh and consider. Some books are to be tasted, others to be swallowed and some few to be chewed and digested, that is some books are to be read only in parts; other to be read but not curiously, and some to be read wholly and with diligence and action. Some books also may be read by deputy, and extracts made of them by others, but that would be only in the less important arguments and the meaner sort of books, else distilled books are like common distilled waters, flashy things.

3. Study the following text carefully and prepare a note and convert it into a summary. [5+5]

As with conversation, broadcast *media* talk can create each of these relations. Continuity announcements, weather forecasts and some other formats adopt a style of direct address to the audience. Interviews, studio discussion and other formats embed staged dialogue between designated performers (in the studio, linked by satellite, etc.) within the broadcast to the audience. That audience is accordingly cast in the role of overhearers of exchanges represented in the broadcast. Members of the audience are still ratified participants in the broadcast, nevertheless. Their presence and involvement are in fact its main purpose.

Whether members of a media audience are 'addressees' is more complicated. Production and reception of media discourse relate to one another across 'split contexts'. One place and time (or period) is involved in production but many different places (and possibly different times) are possible as the moment of reception. No particular audience member is known to or identified by broadcasters as they communicate. Nor do they know what mix of people will be watching or listening, even if they have access to generalised audience demographics (e.g. the proportion of people of different ages, or gender or class groups, likely to be listening or watching). In such circumstances, producers rely on their estimate of who the likely audience will be, how members of that audience may wish to be talked to, and how they will respond to various cues. Mode of address in media talk is based on a sense (sometimes a stereotypical sense) of what type of people might be listening or viewing and what those people want. To the extent that members of an audience recognise some aspect of themselves in the approach adopted, they allow themselves to be 'addressed' by the overall broadcast discourse. This is the case even if what they are listening to is embedded interaction that they 'overhear' between other, staged voices.

4. Answer any two of the following questions: [5×2]
- "Studies serve for delight, for ornament, and for ability." Elucidate. (Of Studies)
 - Describe in detail the role of curiosity, imagination and observation in scientific inventions. (The Scientific Attitude)
 - "Einstein was the greatest genius of the 20th century". Explain it. (What Einstein Did?)
5. Fill up the following blanks selecting the correct words from the brackets: [0.5×10]
- The Prime Minister, along with his cabinet members,.....gone abroad. (has/have)
 - The poet and artist honoured. (has been/have been)
 - If I you, I wouldn't make such remarks. (am, were)
 - Had I been there, I every part of the city. (had visited, would have visited)
 - The passive voice of 'I love people helping me' is (I love having been helped, I love being helped)
 - She is accustomed..... having spicy food. (with, to)
 - The poor boy is deprived proper schooling. (to, of)
 - I felt the whole building (move, moving)
 - When I saw her, she (was crying, cried)
 - I wish I a better job.(have, had)
6. Change the following bibliographic references as indicated in the brackets: [4]
- Nunan, D.(2001). English as global language. TESOL Quarterly 35(4), 605-606 (into MLA)
 - Gass, S (2001). Innovations in second language research methods. London, OUP (into MLA)
 - Vygotsky, L. Through and language. Cambridge; MIT press, 1986;(into APA)
 - Storch, N. Patterns of interaction is ESL pair work Language Learning. London: OUP, 2002. (into APA)
7. Suppose you are the co-ordinator of a seminar on "Scope of Computer and Electronics Engineering in Nepal" to be held shortly in Kathmandu. Draft a notice for calling the meeting. [5]
8. You have been asked by the Ministry of Civil Aviation of Nepal to inspect any three airports of mountainous areas of Nepal. Supposing that you have conducted your survey, write a letter report focusing on existing conditions and re-recommendations. Invent the necessary details. [6]
9. Write a research article on the problem of global warming in the present day world. [10]
10. Write a proposal on the construction of a multi media lab in your local town including technical section, cost estimate and abstract sections in it. [10]
11. There has been recurring mismatch between the demand for electricity and its supply all over the country in agricultural, commercial and domestic sectors. You have been asked to study the sector-wise power consumption pattern and write a report. Write only the following elements to be incorporated in the report: Abstract, Introduction, Conclusion [10]

Exam.	Regular		
Level	BE	Full Marks	80
Programme	BEL, BEX, BCT B. Agri.	Pass Marks	32
Year / Part	III / I	Time	3 hrs.

Subject: - Communication English (SH601)

- ✓ Candidates are required to give their answers in their own words as far as practicable.
- ✓ Attempt **All** questions.
- ✓ The figures in the margin indicate **Full Marks**.
- ✓ Assume suitable data if necessary.

1. Edit the following:

Two pastors are standing by the side of a road holding up a sign that reads. The end is near turn around now before its too late! A passing driver yells, "you guys are nuts!" and speed past them. From around the curve, they hear screeching tyres- then a big splash. One of the pastors says to the other, do you think we should just put up a sign that says Bridge broken instead?

[5]

2. Study the following paragraph carefully and interpret it in your own words:

The prevention of free inquiry is unavoidable so long as the purpose of education is to produce belief rather than thought to compel the young to hold positive opinions on doubtful matters rather than to let them see the doubtfulness and be encouraged to independence of mind. Education ought to foster the wish for truth, not the conviction that some particular creed is the truth.

[5]

3. Study the following text carefully, prepare notes and convert it into summary:

One day in 2003, while on her morning walk in the park, Valavolkar felt a sharp pain in her left shoulder. The pain soon subsided and she decided to go about her chores.

[5+5]

But a few hours later, the waves of pain returned when she was out walking again, this time to see the neighbourhood dentist about a cavity. It was much more intense than in the morning. Overwhelmed with nausea, dizziness and shoulder pain that grew more intense with every step she took, she felt too weak to move. Anyhow, her husband and son being away at work, she assumed it was spondy litis and got in touch with a family friend, an orthopedic doctor, who insisted she see a heart specialist immediately.

At workhardt hospital soon afterwards, it became clear to the medics that she was having a myocardial infarction, a heart-attack caused by the blockages- in Valavalkar's case of three blood vessels to the heart. One of them, a key artery, had a 95 percent blockage. An angioplasty was performed and a stent inserted to open up the blockage. Her medical care had been so swift, however, that there was no serious damage to the heart muscle.

Since then she hadn't been without trouble, but a cardiac rehab programe she entered in 2006 has-helped her lead a normal life. "I feel fine now," Valvakar says, looking back. "Periodic check ups are essential and fortunately for me, these have revealed no problems. I am very active now. I even counsel other heart patients to help them stay positive."

"Women have different risk factors for cardiac disease than men, but there is such little awareness, " says Dr.Vanita Arora cardiae electrophysiologist and associate director at the Max Health Care Superspeciality Hospital in New Delhi.

4. Answer any two of the following questions:

[5+5]

- a) Point out weaknesses of steam boilers and suggest any other better option of source of energy in context of Nepal. Tell why you think that could be the better option. (Steam Boilers)
- b) In recent years we Nepalese have seen colorful advertisements in newspapers about multi-storeyed apartments from different housing companies. In relation to this, talk about the suitability of the text "Piles for Foundations."
- c) Describe the various features that contribute to wisdom with reference to the text "Knowledge and Wisdom".

5. Fill up the following blank spaces selecting the correct words from the brackets: [0.5×10]
- He, along with his teachers,playing. (is, are)
 - The principal and accountant.....on leave. (is, are)
 - Ita long time since he telephoned me. (is, has been)
 - It's high time hethe job. (got, has got)
 - Had it not been a hot day, wea lot. (had worked, would have worked)
 - Should that happen, Ithe job. (should quit, will quit)
 - I'll standyou whatever happens. (for, by)
 - The project is runningfinancial difficulties. (with, into)
 - The passive voice of "I remember him teaching me algebra" is (I remember being taught algebra/I remember to being taught algebra by him.)
 - The passive voice of "I saw him crossing the road" is (He was seen crossing the road by me/He was seen to be crossing the road.)
6. Convert the following APA style into MLA and MLA into APA: [4]
- Santos, Richard. "Tax break?" The New Republic. 12 July. 1998: 24-40
 - Scotto, P.Censorship, Reading and Interpretation. (2011) ~~Studies~~ in American Obfuscation 61-70.
 - Fetler, Jane. "Critical People Cause Office Fireworks" (2010, June 4). The Providence Journal, P.A1.
 - Prepare in text citation for:
Wang, P. (1999, July) Fund Watch. Money, PP.49-54.
7. Assume that you have been appointed secretary of a committee comprising management, staff and workers representatives to advise the company to produce a handbook containing information about conditions of service, rules and regulations of fringe benefits and other related matters. Write a notice to call a meeting to discuss above matters. [5]
8. Suppose you are the chief consultant of Road Expansion Project being launched in the capital city Kathmandu. Write the second quarterly progress report in memo style. [6]
9. Write a brief research article on advancements made in the last decade in your field of engineering. [10]
10. Most communities do not have a place for scientists and citizens to meet to discuss important issues. You have a way to meet the needs of citizens who lack access to scientific expertise by bringing together scientists and non scientists to identify, discuss and resolve issues of public concern. Therefore as a matchmaker for groups and resources write a proposal. Include an introduction stating the problem and its significance. Discuss the proposed outcome and include a time table. [10]
11. Imagine that Government of Nepal has formed a committee under your chairmanship for the purpose of studying the effect of noise pollution in the industrialized towns in Nepal. Prepare only the title page, abstract, table of contents and recommendations sections of the report that you are going to submit shortly. [10]

Exam.	New Back (2066 & Later Batch)		
Level	BE	Full Marks	80
Programme	BEL, BEX, BCT, B.Agri	Pass Marks	32
Year / Part	III / I	Time	3 hrs.

Subject: - Communication English (SH601)

- ✓ Candidates are required to give their answers in their own words as far as practicable.
- ✓ Attempt All questions.
- ✓ The figures in the margin indicate Full Marks.
- ✓ Assume suitable data if necessary.

1. Edit the following text to make it error free: [5]

A woman husband had been seriously ill but finally the doctor announces that he would live. What do you mean? You told me that he couldn't last another two weeks, complained the wife. "Well, I'm going to cure him after all. Surely you're glad aren't you" replied the doctor. It puts me in kind of a trouble said the woman I've gone and sold his clothes to pay for the funeral.

2. Read the following text and interpret its meaning in your own language: [5]

Now mark another big difference between then natural slavery of man to nature and the unnatural slavery of man to man. Nature is kind to her slaves if she forces you to eat and drink, she makes eating and drinking so pleasant that when we can affect it we eat and drink too much. We must sleep or go mad; but then sleep is so pleasant that we have great difficulty in getting up in the morning.

3. Read the following text carefully, make notes and write a summary. [5+5]

Colonising space could be much more difficult than we imagine. Scientific studies suggest that children born in space might suffer permanent nervous-system damage unless exposed to Earth-like gravity at key points in their development. One difficulty could be learning how to walk. Young children born in space could have trouble walking on Earth because their nervous systems would have developed in the low-gravity environment of space. Even adults might have difficulty fully re-adjusting to life Earth after prolonged periods of weightlessness.

Scientists are just beginning to discover the importance of gravity in the development of life. They are already aware that it has a serious effect on cell metabolism, brain development and DNA synthesis. For this reason pregnant women cannot go into space. Studies of 18 pregnant mice launched into space carrying some 200 fetuses at varying stages of which is a normal aspect of development, slowed down in space, as did cell reproduction. Without gravity the space-grown brains were smaller and had fewer nerve cells than normal mouse brains. How this would affect the functioning of the brain in an adult animal requires further study.

Another effect could be muscle wasting. This has already been observed in astronauts, although there is disagreement as to whether it is linked to the effects of gravity on the muscle cells or just the lack of muscle use. In any case, loss of muscle strength in space has so far proven to be temporary and there are no confirmed reports of any long-term illness in people returning from long periods in space.

Other studies have produced mixed findings. One study showed that laboratory rats reared in space could not figure out how to walk properly on Earth due to spinal-cord damage suffered in space. This study also showed that newborn pups, which are born blind, need gravity in order to learn how to hold themselves upright. Other findings confirm that adult subjects, including humans, can fairly easily recover balance and navigational abilities that have been lost in space.

Clearly the importance of gravity in the development of human beings requires further study before individuals can be sent off to colonise space.

4. Answer any two of the following question. [10]
- a) How are cables constructed and used in suspension bridges? (Suspension Bridges)
 - b) What do you mean by scientific altitude? Name some qualities of a scientist.
 - c) How did the mother do the duties of a mother and citizen? (The mother of a Traitor)
5. Choose the best words to complete the following sentences. [5]
- a) He knew that he had a toothache while he his teeth. (brushed, was brushing, had brushed)
 - b) People dispersed as soon as they and explosion heard, were hearing, had heard?
 - c) You must respect others in order to (respect, be respectful, be respected)
 - d) by the police, the suspects put their hands up. (to be warned, as warned, having been warned)
 - e) The minister along with his secretaries..... been invited. (has, have)
 - f) Some furniture needed for the office. (is, are)
 - g) If she in your place, she would resign immediately. (was, had been, were)
 - h) Anything if the neighbors had not been there. (could happen, can happen, could have happened)
 - i) I object your coming late. (to, for, at)
 - j) That woman has to care three children. (to, for, by)
6. Arrange the following into APA and MLA styles of citations. [4]
- Author's name: Nunan, D
Book name: Understanding Language Classroom
Publishing place: U.K
Publisher: Prentice Hall
Publishing date: 1989
7. As the secretary of Atul Engineering Consultancy Services, draft a notice for its 6th meeting along with 3 agenda. [5]
8. I imagine that you are working on suspension bridge construction project. Write the first monthly progress report of the project in a memo format. [6]
9. Write a short research article on the importance of internet to the engineering students. [10]
10. Imagine that you are asked to write a proposal on the construction of a water storage tank in a remote village. Write the following parts of the proposal. [10]
- Abstract, statement of the problem, objectives.
11. Suppose you are the chief Executives Engineer of a project related to the construction of a road in a remote part of Nepal and the project is to be completed very soon. Write abstract, introduction, methodology and finding of the reports. [10]

27 TRIBHUVAN UNIVERSITY
INSTITUTE OF ENGINEERING
Examination Control Division
2070 Chaitra

Exam.	Regular		
Level	BE	Full Marks	80
Programme	BEL, BEX, BCT, B.Agric.	Pass Marks	32
Year / Part	III / I	Time	3 hrs.

Subject: - Communication English (SH601)

- ✓ Candidates are required to give their answers in their own words as far as practicable.
- ✓ Attempt All questions.
- ✓ The figures in the margin indicate Full Marks.
- ✓ Assume suitable data if necessary.

1. Edit the text given below:

Incessant practices went up, and the day came when we had to leave to America to study at an advance institute. Always my father was there to guide me. Today, I'm quite a successful pianist, but my father does not stop saying practice more. God smiles and the perfection just glitters when practise touches the top. I now know much than ever that ceaseless effort is the key of success.

[5]

2. Read the following text carefully and interpret it so as to make the meaning clear:

The reason why this book has been specially prepared to make it enjoyable reading for people to whom English is a second or foreign language is that an English writer never thinks of avoiding unusual words, so that the learner, trying to read the book in its original form, has to turn frequently to the dictionary and so loses much of the pleasure that the book ought to give.

[5]

3. Study the following text carefully. Prepare its note and convert it into summary.

We are well acquainted with the fact that men and women are different in terms of appearance. What many people do not realize is that they are also different in communication technique. Generally speaking, men and women fall into two categories when dealing with communication techniques. When men talk, it is for giving information. This informative speaking is "report talk". "Report-talk" is defined as "public speaking". Women on the other hand, use "small talk" to communicate. "Small talk" is a conversation which is usually considered to be short and meaningless. This communication technique of women is "rapport-talk". "Rapport-talk" in other words is "private speaking".

[5+5]

Without being aware that we are supposed to be different, men and women are at odds with each other. The reason why we become angry or frustrated with the opposite sex is because we have forgotten this fact. They want their opposites to "want what they want" and "feel what they feel". This very attitude makes a path for disappointment and prevents them to take the necessary time to communicate loving about their differences.

Men mistakenly expect women to think, communicate and react the way men do. Women mistakenly expect men to feel, communicate and respond the way women do. That is the time when unnecessary friction and conflict occur.

Individuals should be aware that you could use different styles of conversation to fit the information that you are trying to present. You should also never assume that the opposite sex is going to understand what you are trying to say. You should never criticize others who communicate differently than you. Men and women are ruthless about criticizing the opposite sex.

It is never too late to increase the love in your life. You only need to learn a new way. Whether you are in therapy or not, if you want to have more fulfilling relationship with the opposite sex, it is essential to learn new and healthy ways of relating and communicating.

01/14

4. Answer any two of the following questions: [5x2]
- "Even the best technicians should also be good citizens." Do you agree? If yes, why? (Knowledge and Wisdom)
 - How do modern boilers function? (Steam Boilers)
 - What is the central theme of "Civil Peace"? (Civil Peace)
5. Choose the correct words from the brackets and fill in the blanks: [0.5x10]
- Look your health (to, up)
 - I feel the room (move, to move)
 - If I you, I would not do it. (be, were)
 - I heard him Narayan Gopal's song (singing, sing)
 - She cannot part her jewels (from, with)
 - He died T.B last year. (with, of)
 - She walked as if she a lot. (drank, had drunk)
 - He as well as his comrades out (is, are)
 - The teacher said that are mortal (we, they)
 - You alone can relieve me this anxiety (from, of)
6. Change the following bibliographic references as indicated in the brackets: [4]
- Jones, Leo. (1998). Cambridge Advanced English. CUP: New Delhi. (into MLA)
 - Sasikumar, J. and Gunshekhkar, P. Spectrum. Orient Longman: New Delhi, 1977. (into APA)
 - Leech, G. and Svartvik, J. A Communicative Grammar of English. ELBS: England, 1975. (into APA)
 - Quirk, Randolph and Greenbaum, Sidney. (1973). A University Grammar of English. ELBS: England. (into MLA)
7. Write minutes of a recently conducted meeting regarding save the Bagmati River. [5]
8. Suppose you have recently visited a publishing firm. Write a trip report about your observations. [6]
9. Write a proposal on the establishment of "Drinking water scheme of your local VCD/town) including only Abstract, Introduction and Methodology. [10]
10. Write a brief research article on the importance of forest conservation in Nepal. [10]
11. Assume that you are asked to prepare a final report of a power house construction project. Write only the following parts: Title page, Abstract and Recommendation. [10]

Exam.	Year/Part	Full Marks	Time
Level	BE	80	
Programme	BEL, BEX, BCT, B. Agri.	Pass Marks	32
Year / Part	III / I	Time	3 hrs.

Subject: - Communication English (SH601)

- ✓ Candidates are required to give their answers in their own words as far as practicable.
- ✓ Attempt All questions.
- ✓ The figures in the margin indicate Full Marks.
- ✓ Assume suitable data if necessary.

1. Edit the following text do as to make it free from errors: [5]

It was then that my brother-in-law spoke to me. I m well aware of the hardships faced by these kashmiri vendors he said as i looked at him still confused. they eat in morning then spend the rest of the day roaming around the city on foot hungry and thirsty. When i saw them i wanted to offer them food. But they have their pride. They would never accept anything unless i pretended to be interested in their wares and made the offer of the food look incidental.

2. Read the following text and interpret its meaning on your own: [5]

Read not to contradict and confute, not to believe and take for granted not to find talk and discourse, but to weigh and consider. Some books are to be tasted, others to be swallowed and some few to be chewed and digested, that is some books are to be read only in parts, others to be read but not curiously and some to read wholly and with diliqence and action. Some books also may be read by deputy and extracts made of them by others, but that would be only in the less important arguments and the meaner sort of books else distilled books are like common distilled waters flashy things.

3. Read the following text carefully make notes and write a summary of it. [5+5]

What is a democratic government to do in a country where people are steeped in ignorance and superstition, where there is opposition or resistance to even mild reforms from vested interests is society? It can be said that if the government is to go by consent or consensus it will not be able to do anything. Could the government ever get the consent or consensus of the people for abolition of untouchability? But has untouchability been really abolished? Frankly speaking, ever now the code of manu is in operation, the large part of code thus prepared.

No law, perhaps, can come into full operation unless it is acceptable to the people. And it is not necessary to say that acceptability can not come without conviction. The government had been taking measure after measure to change the social-economic structure to remove disparities, social and economic. Not that all the measure have gone in vain. Feudalism has been abolished; gates of universities, legislatures, government service etc. have been thrown open to all castes and communities, exploitation of the weaker section of the people has been considerably reduced.

But there has been no change in the outlook of the people. Politicians and administrators still behave like feudal lords: corruption, favouritism and nepotism have not shown any sign of abatement; faith is caste system and all that it may stand for has not weakened. In one word, independence, democracy etc have not shattered the age-old beliefs and conviction. No wonder the blind is leading the blind.

4. Answer any two of the following questions: [5×2]

- a) What is the difference between knowledge and wisdom? [Knowledge and wisdom]
- b) Describe the importance of English for engineering with reference to your texts in English. [What Einstein Did]
- c) Why did the mother kill her son? [The mother of a traitor]

5. Choose the correct words from the brackets: [5]

- a) Either you or I Supposed to do it. (are, am)
- b) The teacher said that are mortal. (we, they)
- c) Time and tide for none. (wait, waits)
- d) He as well as his comrades out. (is, are)
- e) She walked as if she a lot (drank, had drunk)
- f) Look your health. (to, up)
- g) She cannot part her jewels. (from, with)
- h) I feel the room (move, to move)
- i) The government decided to increase the salary of their civil servants. (have, has)
- j) He died T.B. last year. (with, of)

6. Transform the following bibliographic reference as indicated in the brackets. [4]

- a) Perkin, H.C. (1975). Air pollution. Mc Graw Hill: New Delhi. (into MLA)
- b) Hall, Douglas. (1989). Digital Circuits and Systems. Macmillan: New York. (into MLA)
- c) Lawrence, T.E. Revolt in the Desert. New York: George H. Dorian, 1927 (into APA)
- d) Nadell, Judith, et al. The Macmillan Writer. Boston: Allyn and Bacon, 1997. (into APA)

7. As a secretary of your college union, write the minutes of a recently conducted fifth meeting inventing five agenda. [5]

8. Suppose you have been working on twelve month project. Write the second monthly progress report in a letter format. [6]

9. Imagine that you are requested to submit a proposal for establishing a sophisticated computer lab in one of the technical companies. Write the background, technical section, cost estimate and title page of the proposal that you are going to submit. Also give an outline of the remaining parts. [10]

10. Write a short research article in about 500 words on the effect of air pollution on the local residents in your town. [10]

11. You are asked to prepare a final report of a project of your engineering field. Write only the following parts: Title page, abstract and recommendation. Also, give the outline of the report. [10]

Exam.	Regular		
Level	BE	Full Marks	80
Programme	BEL, BEX, BCT, B.Agri.	Pass Marks	32
Year / Part	III / I	Time	3 hrs.

Subject: - Communication English (SH601)

- ✓ Candidates are required to give their answers in their own words as far as practicable.
- ✓ Attempt **All** questions.
- ✓ The figures in the margin indicate **Full Marks**.
- ✓ Assume suitable data if necessary.

1. After taking notes, write a summary of the following passage in about one third of the words of the original. [5+5]

From the date of the introduction of the steam locomotive about 130 years ago, there was a continuing increases in the size and weight of trains. This necessitated engines of greater and greater power. In order to achieve this increase in power, much higher steam pressures were required. The modern steam locomotive is capable of generating steam pressures often in excess of 300 lb/in², against the 50lb/in² pressure of Stevenson's 'Rocket'. Normally the demand for increased steam capacity is met by increasing the size of the boiler. However the boiler of a steam locomotive is strictly limited in size by the dimension and load capacity of the railway track which it works on. It is therefore necessary to have a very large heating surface within the boiler.

There are two fire-boxes inside the boiler, an inner one and an outer one, which extend a long way forward. The inner fire-box is linked by tubes to the fire-plate at the front of the boiler. Practically the whole of the heating surface, which includes these fire-tubes, is surrounded by water. A high rate of evaporation in the boiler is essential, in order to generate the large quantities of steam which are required. For this purpose a powerful draught of air is blown over the fire. The steam which is evolved is passed through a super-heater, which raises its temperature and makes it as dry as possible. Rapid evaporation at the heating surface tends to make the steam wet. The use of wet steam necessitates excessively high pressures in the cylinder. Super-heating the steam enables to requisite power to obtained with considerably lower pressures.

The superheated steam is passed to the steam-chest which is attached to the cylinder. From the steam-chest it is introduced into the cylinder at the appropriate moments through ports. These ports are opened and closed by slide valves, which are actuated by the rotation of the locomotive crankshaft. The steam is admitted under pressure to one side of the cylinder, and drives the piston forwards. The inlet port is then closed, and a second charge of steam is admitted at the other side of the cylinder to drive the piston in the reverse direction. The exhaust steam from the first charge is driven out into the atmosphere through a blast pipe. This is done in order to increase the draught over the fire. The reciprocating action of the piston is changed into a rotational movement of the wheels by a connecting rod and crank.

2. Read the following text carefully and interpret it so as to make the meaning clear. [5]

A British survey found that 44 percent of the firms, which started to use robots, met with initial failure and 22 percent abandoned them altogether, mainly because of inadequate technological knowhow and skills at all plant levels.

3. Answer any two of the following questions briefly. [5×2]

- i) Describe the contribution of Einstein to the modern scientific world? (What Einstein Did?)
- ii) Why do the ordinary non-technical people find the words 'oxygen' and 'intelligence' confusing? (Straight and crooked thinking)
- iii) Is English language necessary for an engineering student in Nepal? Justify it.

4. Edit the following passage which contains a good many errors. [5]

Certain jobs mostly simple or hazardous one are irretrievably loses too robotics. Thus spot welders press operators, spray painters cleaners, machine loaders grinding and polishing machine operators is endangered species.

5. Choose the correct words from the brackets: [0.5×10]

- a) The minister, along with his relatives gone to Japan. (has/have)
- b) Neither of us going to attend the programme. (is/are)
- c) It is quite warm december. (for, form)
- d) You alone can relieve me this anxiety. (from, of)
- e) We have nothing about. (to have worried, to be worried)
- f) I remember to the sajarjuna Museum by my father. (to be taken, being taken)
- g) Unless you you will be punished. (lonet pay, pay)
- h) If i you, i would not do it. (be, were)
- i) She was made cloths. (wash, to wash)
- j) I heard him Narayan Gopal's song. (singing, sing)

6. Change the following bibliographic references from APA style into MIA: [4]

- a) Ellis, R.(1996). How culturally appropriate is the communicative approach? EIT Journal, 50 (3)
- b) Goodson, I. (2001). The principled professional. Prospects, xxx (2), 181-188.
- c) Hughes, A. (1989). Testing for language teachers. Cambridge: Cambridge University press.
- d) Nunan, D. (1989). Understanding language classroom. U.K: Prentice Hall.

7. Suppose you are the Manager of a project related to micro hydro-power production plant launched in one of the remote villages in Nepal and your project is going to terminate soon as the work has already been accomplished. Write abstract, introduction, methodology and findings of your report giving just the outline of the remaining parts. [10]

8. Suppose you are the secretary of a social organization in your town and the seventh meeting of the Executive body has been conducted recently. Write the minutes inventing necessary agenda and details. [5]

9. Assume that you are requested the write a proposal on establishing engineering collage in Kathmandu. Write the following parts with the outline of your proposal: Abstract, statement of problem and procedure. [10]

10. Write a brief research article on importance of computers for the development of Nepal. [10]

11. Imagine that a project related to the construction of a lab of your engineering field is going on in a local government office. Write the first monthly progress report on the same project in a memo formate. [6]
