

TRIBHUVAN UNIVERSITY  
INSTITUTE OF ENGINEERING  
**Examination Control Division**  
2079 Bhadra

<b>Exam.</b>	<b>Regular</b>		
<b>Level</b>	BE	<b>Full Marks</b>	80
<b>Programme</b>	BCE	<b>Pass Marks</b>	32
<b>Year / Part</b>	III / I	<b>Time</b>	3 hrs.

**Subject: - Foundation Engineering (CE 602)**

- ✓ Candidates are required to give their answers in their own words as far as practicable.
- ✓ Attempt All questions.
- ✓ The figures in the margin indicate Full Marks.
- ✓ Assume suitable data if necessary.

1. What are the factors that influence the selection of a foundation? Under what circumstances strap footings and combined footings are adopted? [1+1]
2. a) Differentiate between accessible and inaccessible method of exploration. How do you determine the depth of exploration? Explain with the help of suitable example. [2+3]
- b) Explain the various precautions to be taken during the sampling, transportation and storage of the sample. [3]
- c) What is the physical meaning of area ratio, inside clearance, outside clearance and recovery ratio? (No need to write formula) [4]
3. a) Justify with suitable reasons for not considering the passive earth pressure during the design of rigid retaining structures. [2]
- b) Describe step by step procedure of Culmann's method of determining active thrust behind the retaining wall carrying inclined backfill with line load with the help of sketch. [5]
- c) A 6 m high retaining wall having vertical back has horizontal cohesion-less backfill having  $\gamma = 17 \text{ kN/m}^3$ ,  $\phi = 30^\circ$  and carrying uniform surcharge of  $25 \text{ kN/m}^2$  has a water table at a depth of 3.5 m from the base of the retaining wall. Determine the magnitude and direction of total active thrust. Take  $\gamma_{\text{sat}} = 21 \text{ kN/m}^3$ . [9]
4. Define strut load, braced cut and explain the Terzaghi's trap door experiment. [1+1+2]
5. Why sheet pile wall considered as a flexible retaining structure? Explain the function of coffer dams with relative merits and demerits. [2+2]
6. a) Explain the various limitations of the plate load test. [3]
- b) A concrete column has a square footing to carry a column load of 750 kN, founded in a clay deposit below the ground surface. The unit weight and unit cohesion of clay are  $17 \text{ kN/m}^3$ ,  $35 \text{ kN/m}^2$  respectively. Determine the dimension of the footing taking factor safety of 3 and assuming the foundation to be backfilled. [6]
- c) Describe the procedure for the proportionating of footings for uniform settlement. [3]
7. Write down the procedure of analysis of mat foundation by conventional method with neat sketch. [6]
8. a) Compare among the large displacement piles, small displacement piles and non-displacement piles with the suitable examples. [2]
- b) Explain the factors affecting selection of pile foundation types. [2]
- c) 12 circular piles are arranged in a rectangular pattern with spacing to diameter ratio equal to 3.0 in a purely cohesive soil having unconfined compressive strength of  $q_u = 80 \text{ kN/m}^2$ . The length of the pile is 15 m and taking adhesion factor as 0.85, determine the spacing and diameter of the pile considering the 100% efficiency of pile group. [8]
9. How do you determine the depth of the well? Describe the sinking process of the well in the site having water table above the ground level. [4+4]
10. Explain the following: [2+2]
  - a) Preloading
  - b) Bituminous stabilization of soil



Exam.	Back		
Level	BE	Full Marks	80
Programme	BCE	Pass Marks	32
Year / Part	III / I	Time	3 hrs.

**Subject: - Foundation Engineering (CE 602)**

- ✓ Candidates are required to give their answers in their own words as far as practicable.
- ✓ Attempt All questions.
- ✓ The figures in the margin indicate Full Marks.
- ✓ Assume suitable data if necessary.

1. What are the basic criteria that needs to be satisfied by foundations for its satisfactory performance? [2]
2. Explain the following with suitable example: [3×4]
  - a) Objectives of site investigation.
  - b) Accessible and inaccessible method of soil exploration
  - c) Thick walled and thin walled sampler
  - d) Representative and non-preventative soil sample
3. a) Write down the step by step procedure of Culmann's graphical method for determining the total active thrust behind the retaining wall carrying surcharge on the cohesion-less inclined backfill. [5]
  - b) For a gravity retaining wall as shown below, determine the following using Coulomb's earth pressure theory. [11]
    - i) FOS against overturning
    - ii) FOS against sliding
    - iii) The pressure on the soil at the toe and heel

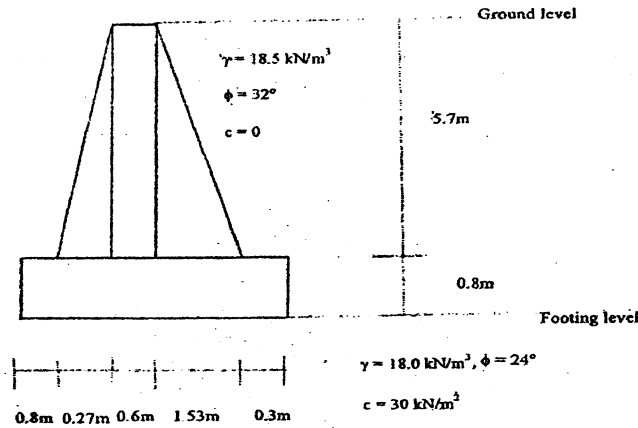

4. Explain Terzaghi trap door experiment to demonstrate the arching effect in soil with suitable sketches. [4]
5. a) What is coffer dam?  
 b) Explain the steps to be followed while designing a full length of general cantilever sheet pile wall if the dredge depth is 'h' meters from the top ground surface and depth of embedment is 'd' from dredge level. Take sandy soil layer above dredge level and clayey soil below the dredge level. Mention all other necessary conditions assumed. [1+3]

6. a) Describe the limitations of the Terzaghi's bearing capacity equation. [3]
- b) A square footing has to be constructed on the cohesion-less soil as shown in the figure below. Assuming  $\gamma = 16.5 \text{ kN/m}^3$ ,  $\gamma_{\text{sat}} = 18.5 \text{ kN/m}^3$ ,  $\phi = 34^\circ$ , and FOS = 3, determine the size of the footing if the gross allowable load on the footing is to be 675 kN. Take  $N_q = 29.44$  and  $N_\gamma = 41.06$ . [9]

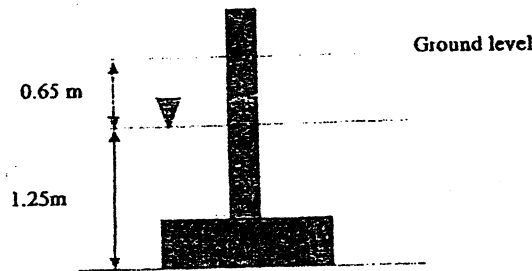

7. Explain the following. [3×2]
- Fully floated and partially floated raft.
  - Various conditions that result the selection of raft foundation.
  - Differentiate the raft of types: plate thickened under column and beam slab structures.
8. a) What is negative skin friction? What are the conditions where a pile foundation is more suitable than shallow foundation? [2+3]
- b) A group of 9 piles, 15 m long and 350 mm in diameter is to be arranged in square pattern in clay with average unconfined compressive strength of  $80 \text{ kN/m}^2$ . Determine the center to center spacing of the piles for the efficiency of 1. Neglect the point bearing. [7]
9. Explain with clear sketches the various components of well foundations. What are the sinking procedure of the well and mention the measures to be taken for sinking the wells and correcting the tilts and shifts occurred during sinking of cassions. [3+5]
10. a) Define soil stabilization and mention its necessities. [2]
- b) Describe various methods involved in mechanical soil stabilization. [2]

\*\*\*



Exam.	Regular		
Level	BE	Full Marks	80
Programme	BCE	Pass Marks	32
Year / Part	III / 1	Time	3 hrs.

**Subject: - Foundation Engineering (CE 602)**

- ✓ Candidates are required to give their answers in their own words as far as practicable.
- ✓ Attempt All questions.
- ✓ The figures in the margin indicate Full Marks.
- ✓ Assume suitable data if necessary.

1. Why foundations are used? Describe different types of foundation. [2]
2. a) Describe in detail the importance of site investigation and stages of site investigation. How the depth of borehole is decided in various projects. [4+3]
- b) Differentiate disturbed and undisturbed soil samples. What are the factors affecting quality of a sample. [2+1]
- c) The internal diameter of a sampler is 40 mm and the external diameter is 42 mm. Will you consider the sample obtained from the sampler as disturbed or undisturbed? [2]
3. a) Draw the plot showing the relationship between lateral earth pressure force per unit length of the wall vs. movement of retaining wall. [2]
- b) Different assumptions are made while considering Rankine's theory and Coulomb's theory for finding lateral earth pressure force per unit length of the wall. Point out four basic differences made during assumption. [4]
- c) Check the stability of the retaining wall shown in figure below. Assume necessary conditions and take ultimate bearing capacity of the foundation soil as  $250 \text{ kN/m}^2$ . [10]

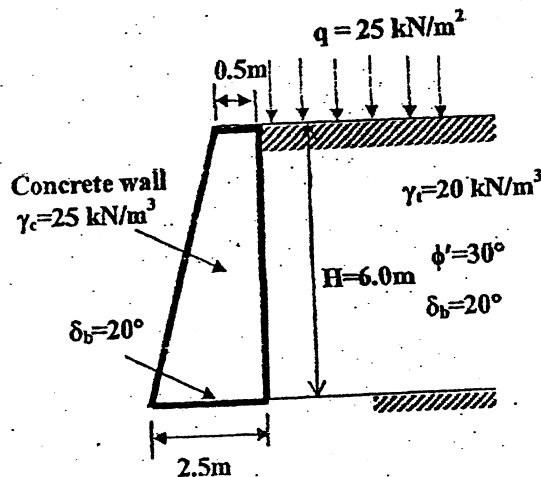

4. Describe the following: [2x2]
  - a) Criteria of selecting the pressure diagram for soil having sand and clay layer in braced cut
  - b) Arching of soil and its basic requirements
5. a) Write down the differences between free earth and fixed earth support anchored pile. [2]
- b) Define cofferdam and explain the cellular cofferdam with the help of neat sketch. [2]

6. a) State the different modes of shear failure. In what way the local shear failure differs from general shear failure? [4]
- b) A footing of  $2\text{m} \times 3\text{m}$  in plan is founded  $2\text{m}$  below the ground level in clay having angle of repose  $\phi = 35^\circ$ ,  $c = 25\text{kPa}$ , what will be the allowable load which can be carried by the footing if the load is eccentrically applied with eccentricity along X and Y direction as  $0.2\text{m}$  and  $0.3\text{m}$  respectively. The center of footing in plan is taken as origin. The water table is located  $0.8\text{m}$  below the ground level. Assume soil above water table is as dry. Take dry and saturated unit weight of clay as  $16.5\text{ kN/m}^3$  and  $19.6\text{ kN/m}^3$  respectively. Take  $N_c = 57.8$ ,  $N_q = 41.4$  and  $N_\gamma = 42.4$ . Take FOS as 3.
7. Write down the concept of compensated foundation. Describe with sketches the various types of mat foundations. [6]
8. Explain the inclined pile. Determine the allowable pile load capacity of the  $400\text{ mm}$  diameter driven concrete pile shown in the following figure. [2+10]

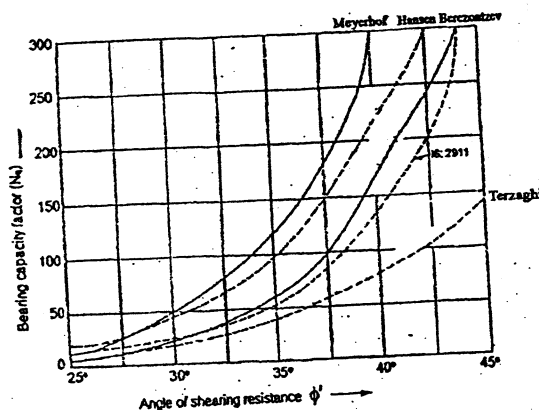
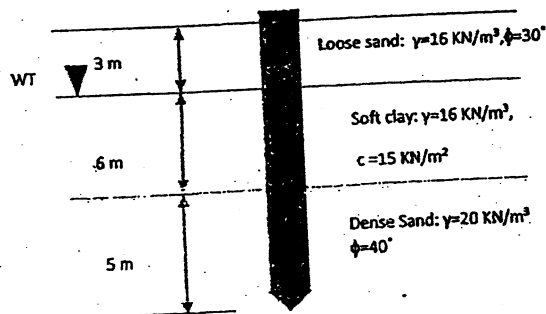

Pile material	$\delta$	Values of K	
Steel	$20^\circ$	0.5	1
Concrete	$0.75\phi$	1	2
Timber	$0.67\phi$	1.5	4

9. a) Explain with clear sketches the various components of well foundations. [4]
- b) How do you rectify the tilt and shift in the construction of well foundations? [4]
10. a) Write down names of different types of mechanical and dynamic compaction used in regard with foundation soil improvements. [1]
- b) In order to increase the engineering properties of soils, soil stabilization is done. Briefly explain the preloading and stone columns for foundation soil improvements. [3]

\*\*\*

Exam.	Back		
Level	BE	Full Marks	80
Programme	BCE	Pass Marks	32
Year / Part	III / I	Time	3 hrs.

**Subject: - Foundation Engineering (CE 602)**

- ✓ Candidates are required to give their answers in their own words as far as practicable.
- ✓ Attempt All questions.
- ✓ The figures in the margin indicate Full Marks.
- ✓ Assume suitable data if necessary.

1. Identify the factors that influence the choice of foundation. What are the things that you will consider while preparing the site investigation report? [2+4]
2. In a site investigation for the design of bridge foundation, what kind of detail information do you set out to obtain? Describe briefly the limitations of plate load test. [5+3]
3. a) What general guidelines are adopted before checking the stability of different types of retaining walls? Explain the different design considerations for retaining walls. [5+3]  
 b) A retaining wall of 7.5 m high has two layers of backfill. The soil supported consists of 4.5 m sand ( $\gamma = 18 \text{ kN/m}^3$ ,  $\phi = 35^\circ$ ) overlaying saturated clayey soil ( $\gamma = 19.5 \text{ kN/m}^3$ ,  $\phi = 30^\circ$ ,  $C = 16 \text{ kN/m}^2$ ). The ground water table is at the upper surface of the clay. Make a sketch of the distribution of the active pressure on the wall stating the principal values. Calculate the total earth thrust per meter of the wall and its point of application. Assume that the backfill is horizontal at the surface. [8]
4. Explain the phenomenon of arching in soils. In what respects does the design of flexible retaining walls vary from that of a rigid retaining wall? [1+3]
5. Enlist the uses of sheet pile. Write down the step by step procedure of analysis of anchored sheet pile by free earth support method in granular soil. [1+3]
6. a) Discuss on the findings of Skempton on clayey soil regarding net safe bearing capacity. Why is more differential settlement allowed in clay than in sand? [2+2]  
 b) A footing  $2 \text{ m} \times 3 \text{ m}$  in plan which is to be laid at a depth of 1.5 m below ground surface to carry a column load having one way eccentricity of 0.26 m along the width. Determine the safe bearing capacity if the water table is 0.5 m below the ground level. Use Terzaghi's theory. Take  $c = 20 \text{ kN/m}^2$ ,  $\phi = 35^\circ$  to interpolate the bearing capacity factors from the figure presented. [8]

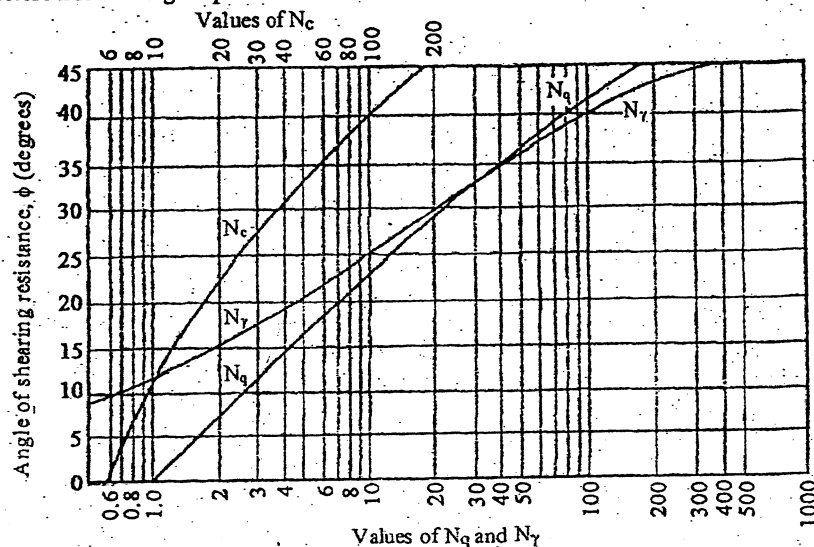

7. a) Define fully compensated raft foundation. Also derive the relation to calculate its depth. [1+1]
- b) Determine the allowable bearing pressure of a raft foundation  $3\text{ m} \times 12\text{ m}$  in plan, resting at depth of  $2\text{ m}$  on cohesionless soil. The corrected  $N$  value over a depth of  $12\text{ m}$  was  $22$ . It is specified that the differential settlement is not to exceed  $20\text{ mm}$ . Water table is at depth of  $4\text{ m}$  below the ground level. [4]
8. a) What are the conditions where a pile foundation is more suitable than a shallow foundation? How negative skin friction is calculated for a single pile and group of piles in clay? [2+3]
- b) A friction pile  $350\text{ mm}$  diameter is proposed to be driven in a layer of uniform cohesive soil with unconfined compressive strength of  $80\text{ kPa}$ . Considering the pile end carry only  $30\%$  of the total load, determine the length of the pile required for the ultimate load of  $1200\text{ kN}$ . Assume adhesion factor  $= 0.80$ . [7]
9. What is a well foundation? Show all components in a neat sketch. Discuss the remedies for tilt and shift of well foundation. [1+4+3]
10. Describe mechanical and chemical method of soil stabilization. [2+2]

\*\*\*

Exam.	Regular		
Level	BE	Full Marks	80
Programme	BCE	Pass Marks	32
Year / Part	III / 1	Time	3 hrs.

**Subject: - Foundation Engineering (CE 602)**

- ✓ Candidates are required to give their answers in their own words as far as practicable.
- ✓ Attempt All questions.
- ✓ The figures in the margin indicate **Full Marks**.
- ✓ Assume suitable data if necessary.

1. Classify the shallow and deep foundations according to their soil conditions. [2]
2. a) What is standard penetration test? What are the corrections that must be applied to the SPT-values for sand before they are used in design charts and empirical correlations? [1+4]  
b) What is meant by inside and outside clearance? What are the circumstances which make the plate load test data misleading when used for extrapolation of prototype behaviour? [2+5]
3. a) Explain the various reasons for neglecting the passive pressure during the stability analysis of retaining wall. Describe the Culmann's method for determining active thrust for the inclined backfill carrying the surcharge load. [3+5]  
b) Calculate the total passive thrust and its point of application coming on the back of the following retaining wall. [8]

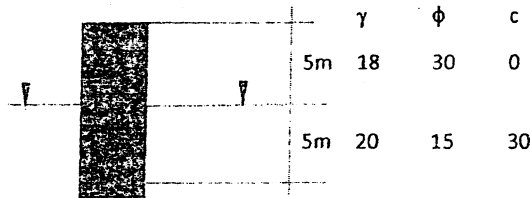

4. What is arching in soil? What are the essential requirements for arching effect to come into play? [1+3]
5. In what respects does the design of bracings in cuts vary from that of a retaining walls? Enlist the types of cofferdam with neat sketches. [2+2]
6. a) Describe the different modes of failure due to the settlement with neat sketches. [5]  
b) Determine the size of the footing resting over sand to carry a column load of 150 tons. The bottom of the footing is 1.5 m below the ground level and water table is located at 3 m below the footing. Take unit weight of sand is 20 KN/m<sup>3</sup>. Assume  $N_c = 55.2$ ,  $N_q = 39.51$  and  $N_\gamma = 40.13$ . [7]
7. A raft foundation is 20m  $\times$  10m exerts a gross pressure of 200KN/m<sup>2</sup> at the foundation level. The depth of foundation is 2.5m. If the soil is clay  $C_u = 80$ KN/m<sup>2</sup> and  $\gamma = 19$  KN/m<sup>3</sup>. Determine the Factor of Safety, Use Skempton's equations. [6]
8. a) Describe the various method of determining the settlement of pile group in sand. Describe about the piles subjected to uplift loads. [3+2]  
b) A friction pile 300 mm in diameter is proposed to be driven in a layer of uniform soil having unit skin friction between pile surface and soil as 60 KN/m<sup>2</sup>. Determine the length of the pile required to carry allowable load of 250 KN assuming the pile tip carries 20% of the total load. [7]
9. Define grip length and tilt and shift of well. Describe the various components of well foundation. [2+6]
10. Write down the different methods of soil improvement techniques. Explain about preloading method for improvement of foundation soil. [2+2]



**TRIBHUVAN UNIVERSITY**  
**INSTITUTE OF ENGINEERING**  
**Examination Control Division**  
**2076 Ashwin**

Exam.	Back		
	Level	BE	Full Marks
Programme	BCE	Pass Marks	32
Year / Part	III / I	Time	3 hrs.

**Subject: - Foundation Engineering (CE 602)**

- ✓ Candidates are required to give their answers in their own words as far as practicable.
- ✓ Attempt All questions.
- ✓ The figures in the margin indicate Full Marks.
- ✓ Assume suitable data if necessary.

1. Explain the major criteria to be satisfied in the design of a foundation. [2]
2. a) What makes pressure meter testing quite distinctive as compared to other field tests? [2]
- b) List the factors that will consider for deciding the depth of soil exploration. If you are in-charge of subsoil exploration of important structures, how do you decide the depth and lateral extent of soil exploration? [2+5]
- c) A soil sampler has the following dimensions: inside diameter of the cutting edge=69 mm; outside diameter of cutting edge=73 mm; inside diameter of the sampling tube = 70mm and outside diameter of the sampling tube = 72 mm. Calculate: (i) inside clearance (ii) outside clearance and (iii) area ratio of the sampler. [3]
3. a) What do you understand by "General State of Plastic Equilibrium"? How the retaining walls can be proportioned? [3+5]
- b) A 6 m high vertical wall supports a saturated cohesive backfill with horizontal surface. The top 3 m of backfill weighs  $18 \text{ kN/m}^3$  and cohesion of  $18 \text{ kN/m}^2$ . The bulk unit weight and cohesion of bottom 3 m of the wall are  $20 \text{ kN/m}^3$  and  $25 \text{ kN/m}^2$  respectively. What is the likely depth of tension crack? If the tension crack develops what will be the active earth pressure? Draw the pressure distribution diagram and determine the point of application of the resultant pressure. [8]
4. What is arching in soil? What are the essential requirements for arching effect to come into play? Describe Terzaghi's arching theory. [1+1+2]
5. What is cofferdam? An excavation of 5 m deep is to be carried out in sandy soil deposit having unit weight =  $22 \text{ kN/m}^3$  and angle of shearing resistance =  $33^\circ$ . To support the soil, cantilever sheet pile walls are driven into the ground prior to excavation. Determine the depth of embedment needed for the sheet pile to retain the backfill. The water table is located below the base of the sheet pile. [1+3]
6. a) How do you ascertain whether a foundation soil is likely to fail in local shear or in general shear? Explain the limitations of different classical bearing capacity theories. [2+3]
- b) A circular footing of 2.5 m diameter carries a gross load of 2000 KN. The supporting soil is clayey sand ( $\phi=30^\circ$ ,  $\gamma=19 \text{ kN/m}^3$ ). Determine the depth at which the footing should be located to provide the factor of safety 3. Use Terzaghi's theory.  $N_c=37.2$ ,  $N_q=22.5$ ,  $N_\gamma=19.7$  for  $\phi=30^\circ$ . [7]
7. Explain about compensated foundation. Describe with neat sketches the various types of mat foundations. [2+4]
8. a) What are the different circumstances under which a pile foundation is used? How is negative skin friction calculated for a single pile and a group of piles in clay? [1+3]

- b) A 15 m long closed end steel pipe pile group (3×4) consists of 12 piles of a 300 mm diameter and evenly spaced at 900 mm, center-to-center, is driven into layered undrained clay. The top 6 m consists of clay with undrained cohesion of 50 kPa and adhesion factor of 0.74, followed by 6 m of clay with undrained cohesion of 65 kPa and adhesion factor of 0.62, which was underlain by stiff clay with undrained cohesion of 90 kPa and adhesion factor of 0.50. Estimate the allowable load carrying capacity of pile group. Take factor of safety=2.5. [8]
9. What is a well foundation? Show all components in a neat sketch. Discuss the remedies for tilt and shift of well foundation. [1+4+3]
10. What is stone column? Explain the soil stabilization by use of admixture. [1+3]

\*\*\*



TRIBHUVAN UNIVERSITY  
 INSTITUTE OF ENGINEERING  
**Examination Control Division**  
 2075 Chaitra

Exam.	Regular / Back		
Level	BE	Full Marks	80
Programme	BCE	Pass Marks	32
Year / Part	III / I	Time	3 hrs.

**Subject: - Foundation Engineering (CE 602)**

- ✓ Candidates are required to give their answers in their own words as far as practicable.
- ✓ Attempt All questions.
- ✓ The figures in the margin indicate Full Marks.
- ✓ Assume suitable data if necessary.

1. What are the various factors that influence the choice of a foundation? [2]
2. a) Define the physical meaning of terms with reference to the sampling tube, with a neat sketch-i) Inside clearance ratio ii) Outside clearance ratio iii) Area ratio iv) Recovery ratio. Also indicate the recommended values to get least disturbed samples. [6+2]
  - b) A multistoried commercial complex building is to be constructed in a core of a Kathmandu Valley, for this a Geotechnical investigation is to be carried out. As an engineer recommend the number of boreholes, depth of boreholes and spacing of the borehole for subsoil explorations. [4]
3. a) How the different retaining walls can be proportioned? Describe the methods of stability check of retaining wall. [5+3]
  - b) A retaining wall of 7.5m high has two layers of backfill. The soil supported consists of 3m sand ( $\gamma=18\text{KN/m}^3$ ,  $\phi=35^\circ$ ) overlaying saturated clayey soil ( $\gamma=19.5\text{KN/m}^3$ ,  $\phi=35^\circ$ ,  $C=16\text{KN/m}^3$ ). The ground water table is at the upper surface of the clay. Make a sketch of the distribution of the active pressure on the wall. Calculate the total earth trust per meter of the wall and its point of application. Assume that the backfill is horizontal at the surface. [8]
4. What is cofferdams? Describe the types of cofferdams with their uses. [1+3]
5. In what respects does the design of bracings in cuts vary from that of a rigid retaining wall? Describe Terzaghi's arching theory. [2+2]
6. a) Critically differentiate between general shear failure and local shear failure. What are the factors affecting bearing capacity of soil? [2+2]
  - b) A rectangular footing (3m x 4m) is placed at 1.5m depth in sandy soil having angle of shearing resistance of  $34^\circ$  and unit weight of  $20\text{ kN/m}^3$  above water table and saturated unit weight of  $21.5\text{ kN/m}^3$  below water table. Determine the safe load that can be carried by the footing for a safety factor of 3.0 if the excavation is backfilled for the following cases: (i) the water table is at 1m below the ground level and (ii) the water table is at 1m below the base of the footing. The bearing capacity factors for strip footing for  $\phi=34^\circ$  are  $N_q=29$  and  $N_\gamma=41$ . [8]
7. A raft foundation is 20m x 30m. The raft is constructed over a soft clay stratum having  $C_u=10\text{KN/m}^2$  and  $\gamma=19\text{KN/m}^3$ . If the live load and dead load on the raft are 100MN, find the depth of Foundation if
  - a) The foundation is fully compensated.
  - b) Determine the depth of foundation for a factor of safety of 3. [3+3]

8. a) Describe Negative skin friction with its causes, effect, preventive measures. [4]

b) The 20 numbers of concrete pile of 0.3m diameter and 20 meter depth are designed to construct 4 x 5 layout pattern. The site consist of clay with unconfined compressive strength  $80\text{KN/m}^2$ . Design center to center spacing of piles so that group pile has some possibility of individual pile failure an block failure. Take adhesion factor ( $\alpha$ ) =0.5 [8]

9. What considerations govern the fixing of the depth of a well foundation? Name the different methods to analyze the lateral stability of well foundation. A circular well of 4m internal diameter and 0.75m steering thickness is embedded upto a depth of 12m in a uniform sandy deposit. The well is subjected to a resultant horizontal force of 500kN and a total moment of 4000kN-m at the scour level. Calculate the allowable total equivalent resisting force due to earth pressure for the both light well and heavy well conditions using Terzaghi's analysis. Take saturated unit weight of soil of  $20\text{kN/m}^3$ ,  $\phi=30^\circ$  and factor of safety for passive resistance of 2. [1+1+6]

10. What are the different methods of improving the foundation soils? [4]

Exam.	Back		
Level	BE	Full Marks	80
Programme	BCE	Pass Marks	32
Year / Part	III / I	Time	3 hrs.

**Subject: - Foundation Engineering (CE602)**

- ✓ Candidates are required to give their answers in their own words as far as practicable.
- ✓ Attempt All questions.
- ✓ The figures in the margin indicate Full Marks.
- ✓ Normal graph paper should be provided.
- ✓ Assume suitable data if necessary.

1. a) How would you select the suitable type of foundation according to soil conditions? [2]  
 b) Why undisturbed samples are required? [2]
2. a) In a core of a Kathmandu valley a Geotechnical investigation is to be carried out. As an engineer recommend the type of drilling and the suitable field tests such that the test data can be used as much as possible. [5]  
 b) Prepare an example of borehole log format. [3]
3. a) What mathematical procedures are used in checking the stability of retaining wall? Why are retaining walls usually designed for active earth pressure? [2+6]  
 b) A trapezoidal masonry retaining wall 1 m wide at top and 3 m wide at its bottom is 4 m high. The vertical face is retaining soil ( $\phi = 30^\circ$ ) at a surcharge angle of  $20^\circ$  with the horizontal. Determine the maximum and minimum intensities of pressure at the base of the retaining wall. Unit weights of soil and masonry are  $20\text{kN/m}^3$  and  $24\text{kN/m}^3$  respectively. Assuming the coefficient of friction at the base of the wall as 0.45, determine the factor of safety against overturning. [8]
4. Explain arching in soils. Explain heave of the bottom of cut in soft clays. [4]
5. Differentiate between rigid retaining structural and flexible retaining structures in terms of stability and deformation analysis. [4]
6. a) Explain how the bearing capacity of soil is affected by the fluctuation of the water table with neat sketch. [6]  
 b) Below figure shows the load-settlement curve obtained from a plate load test conducted on a sandy soil. The size of the plate used was  $30\text{cm} \times 30\text{cm}$ . Determine the size of a square column footing to carry a net load of  $3200\text{KN}$  with a maximum settlement of  $25\text{mm}$ . [8]

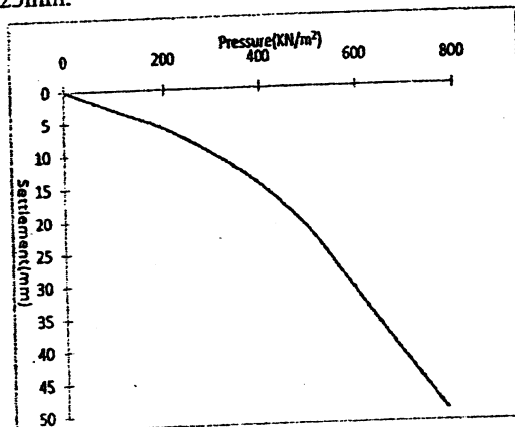

Fig. 1 plate load test

7. The  $10\text{m} \times 15\text{m}$  size mat is constructed at  $2.5\text{m}$  depth having basement for underground parking. The site consists of highly compressible saturated clay having cohesion of  $30\text{ KN/m}^2$ . If the mat carries the total load of  $4000\text{ KN}$ . Calculate the factor of safety. [6]
8. a) Elaborate the behavior of single pile differing in its group actions. [4]
- b) A circular pile group of 16 piles penetrates through a unconsolidated soil of  $3.5\text{m}$  depth. The diameter of circular pile is  $60\text{ cm}$  and pile spacing of  $800\text{cm}$ . The average unconfined compressive strength of material is  $60\text{ KN/m}^2$  and the unit weight of soil is  $16\text{ KN/m}^3$ . Compute the negative skin friction on the group. Take adhesion factor = 1. [8]
9. Discuss the remedies for tilt and shift of well foundation. Describe with clear sketches the components of well foundations. [3+5]
10. What are the purposes of foundation soil improvement? Explain, in brief, vibroflotation techniques. [2+2]

\*\*\*

Exam.	Back		
Level	BE	Full Marks	80
Programme	BCE	Pass Marks	32
Year / Part	III / I	Time	3 hrs.

**Subject: - Foundation Engineering (CE602)**

- ✓ Candidates are required to give their answers in their own words as far as practicable.
- ✓ Attempt All questions.
- ✓ The figures in the margin indicate Full Marks.
- ✓ Assume suitable data if necessary.

1. a) Classify the foundations according to their soil condition. [2]
- b) Explain how standard penetration test is carried out in the field. What various corrections are made on the tested value? Describe the nature of sample obtained from the test. [8]
- c) Describe briefly the limitations of plate load test. [4]
- d) Write down the different methods of improving the bearing capacity of weak soils. [4]
2. a) Explain with neat sketch the step by step procedure for Culmann's graphical method of passive earth pressure. [6]
- b) Determine the maximum and minimum pressure under the base of the cantilever retaining wall as shown in figure below and also the factor of safety against sliding and overturning. The approximate shear strength parameters for the soil are  $c = 0$ ,  $\Phi = 41^\circ$ . The unit weight of soil and concrete are  $16 \text{ KN/m}^3$  and  $24 \text{ KN/m}^3$  respectively. The water table is below the base of the wall. Take  $\delta = 27^\circ$  on the base of the wall. [10]

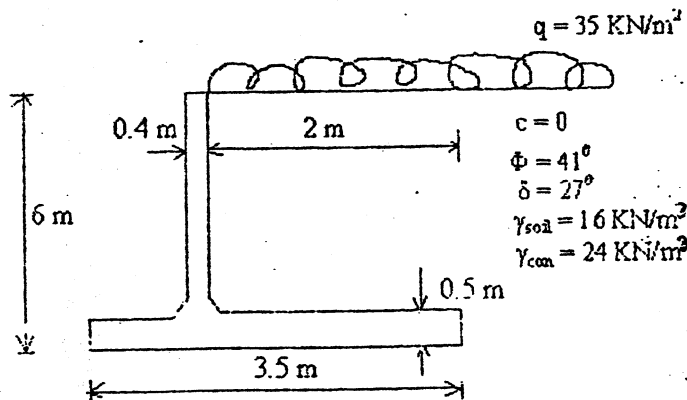

3. a) What is the effect of water table on bearing capacity of soil? A footing was designed based on ultimate bearing capacity arrived for the condition of water table at the ground surface. If there is a chance for raise in water level much above the ground level do you expect any change in the bearing capacity, why? [4]
- b) A circular footing is resting on stiff clay with unconfined compression strength of  $250 \text{ KN/m}^2$ . Determine the diameter of the footing when the depth of foundation is 2 m and the column load is 700 KN assuming a factor of safety as 2.5, the bulk unit weight of soil is  $20 \text{ KN/m}^3$ . What will be the change in ultimate, net ultimate and safe bearing capacity if the water table is at ground level? [8]

4. a) In what respects does the design of flexible retaining structure vary from rigid retaining structure. [3]
- b) A cantilever sheet pile wall is driven into sand deposit having friction angle  $35^\circ$  and bulk unit weight of  $22\text{kN/m}^3$ . One side of the sheet pile was backfilled to 3 m height. The backfill material is cohesion less sand having  $\Phi = 32^\circ$  and bulk unit weight of  $18\text{kN/m}^3$ . Using the simplified method determine the depth of penetration needed for the sheet pile to retain the backfill. Provide a safety factor of 2 for the passive resistance. The water table is below the base of the sheet pile. [5]
5. a) What are the conditions where a pile foundation is more suitable than a shallow foundation? What is a negative skin friction? [3+2]
- b) A group of nine piles, 12 m long and 300 mm in diameter is to be arranged in a square pattern in clay with an average unconfined compressive strength of  $75\text{ KN/m}^2$ . Determine the centre to centre spacing of the piles for the efficiency of 1. Neglect the point bearing. [7]
6. a) How do you determine the depth of the well foundation? Describe the process of sinking of well. [4+4]
- b) Describe the procedure of determining the bearing capacity of cohesive cohesion-less soil in case of mat foundation. What is compensated foundations. [4+2]

\*\*\*

Exam.	Regular		
Level	BE	Full Marks	80
Programme	BCE	Pass Marks	32
Year / Part	III / I	Time	3 hrs.

**Subject: - Foundation Engineering (CE602)**

- ✓ Candidates are required to give their answers in their own words as far as practicable.
- ✓ Attempt All questions.
- ✓ The figures in the margin indicate Full Marks.
- ✓ Assume suitable data if necessary.

1. Classify the shallow and deep foundations according to soil conditions. [2]
2. a) Determine the area ratio of a sampler having external radius of 30 mm and wall thickness of 2.25 mm. Do you recommend this sampler for obtaining undisturbed soil samples and why? [2+1]
- b) List the field tests commonly used in subsurface exploration. What are the corrections that must be applied to the SPT-values for sand before they are used in design charts and empirical correlations? [1+4]
- c) What are the things that you will consider while preparing the site investigation report? [4]
3. a) Explain the relative wall movements and lateral earth pressure coefficients. How do tension cracks influence the distribution of active earth pressure in purely cohesive soils? Distinguish critically between Rankine's and Coulomb's theories of lateral earth pressure. [2+2+2]
- b) A retaining wall of 7.5 m high has two layers of backfill. The soil supported consists of 5m sand ( $\gamma = 18\text{KN/m}^3$ ,  $\phi = 35^\circ$ ) overlaying saturated clayey soil ( $\gamma = 19.5\text{KN/m}^3$ ,  $\phi = 35^\circ$ ,  $C = 16\text{KN/m}^2$ ). The ground water table is at the upper surface of the clay. Make a sketch of the distribution of the active pressure on the wall stating the principal values. Calculate the total earth thrust per meter of the wall and its point of application. Assume that the backfill is horizontal at the surface. [10]
4. What is arching effect in soils? A long 5 m wide and 10 m high vertical trench has to be constructed in a deep deposit of cohesive soil with  $c = 35\text{ kN/m}^2$  and  $\gamma = 18\text{ kN/m}^3$ . The safety of the bottom of trench against heave is to be checked before protecting the trench walls using sheet piles. If the excavation to be completed rapidly, determine the factor of safety against bottom heave. What will be the factor of safety if a hard rock is present at 2.5 m from the bottom of the trench? [1+3]
5. What is coffer dam? Describe with neat sketch of the different types of coffer dam. What are the relative merits and demerits of them? [4]
6. a) What are the implications of settlement on structures? Write down the steps of proportioning footings for uniform settlement. [2+4]
- b) A building is to be supported on a reinforced concrete raft covering an area of 14 m  $\times$  21 m. The subsoil is clay with an unconfined compressive strength of 14  $\text{kN/m}^2$ . The pressure on the soil due to weight of the building and loads it will carry will be 135  $\text{kN/m}^2$ , at the base of the raft. If the unit weight of excavated soil is 19  $\text{kN/m}^3$ , at what depth should the bottom of the raft be placed to provide a factor of safety of 3? Use Skempton's bearing capacity formula. [6]

7. Write down the concept of compensated foundation. Describe with sketches the various types of mat foundations. [1+5]
8. a) What are the various approaches used to estimate the vertical load bearing capacity of a pile? Write causes and effects of negative skin friction in a pile foundation. [1+4]
- b) A group of 16 piles arranged in a square pattern is to be proportioned in a deposit of soft saturated clay. Assuming the piles to be square with side 30 cm and 12 m long, determine the centre to centre spacing of piles for 100% efficiency of the pile group. Take adhesion factor = 0.8 and consider both point bearing and skin friction. [7]
9. What are the advantages of well foundations over the other types of deep foundations? Explain about the methods use to rectify tilt and shift of the well foundation with clear sketches. [2+6]
10. Write down the different methods of soil improvement techniques. Explain sand compaction piles and stone column. [2+2]

\*\*\*



Exam.	Regular		
Level	BE	Full Marks	80
Programme	BCE	Pass Marks	32
Year / Part	III / I	Time	3 hrs.

**Subject: - Foundation Engineering (CE602)**

- ✓ Candidates are required to give their answers in their own words as far as practicable.
- ✓ Attempt All questions.
- ✓ The figures in the margin indicate **Full Marks**.
- ✓ Assume suitable data if necessary.

1. Mention the factors that should be considered while selecting the foundation. [2]
2. a) What is the physical meaning of area ratio, inside clearance ratio and outside clearance ratio? [4]
- b) Discuss the features of good site investigation report. What are the limitations of plate load test? [5+3]
3. a) What are the conditions to be satisfied while designing a retaining wall? [6]
- b) A retaining wall of 7.5 m high has two layers of backfill. The soil supported consists of 4.5 m sand ( $\gamma = 17.5 \text{ KN/m}^3$ ,  $\phi = 30^\circ$ ) overlying saturated sandy clay ( $\gamma = 19.5 \text{ KN/m}^3$ ,  $\phi = 34^\circ$ ,  $c = 16.5 \text{ KN/m}^2$ ). The ground water table is at the upper surface of the sandy clay. Make a sketch of the distribution of the active pressure on the wall. Calculate the total thrust per meter of the wall and its point of application from top of wall. [10]
4. Describe arching of soil. Also describe the step by step procedure of calculating the strut load in case of soft clay with related pressure diagram. [1+3]
5. Find the depth of embedment of 6 m high sheet pile wall retaining the soil having unit weight of  $17 \text{ KN/m}^3$  and angle of internal friction of  $30^\circ$ . The water table is at 2 m below the ground level. Also draw the bending moment diagram and solve it by approximate or simplified method. [4]
6. a) Describe different methods to calculate settlement for cohesive and cohesion-less soil. [6]
- b) The  $18.3\text{m} \times 30.5\text{m}$  size mat is constructed at 1.52m depth. The site consists of highly compressible saturated clay having a unit weight of  $18.87 \text{ KN/m}^3$  and cohesion of  $134 \text{ KN/m}^2$ . If the mat carries the total load of  $111 \times 10^3 \text{ KN}$ . Calculate the factor of safety. [6]
7. What is a mat foundation and how is the bearing capacity of mat foundation calculated in case of the cohesive soil? [6]
8. a) Classify the pile foundations according to their material, load transfer and displacement of soil. [4]
- b) A group of 9 piles 10m long and 350mm in diameter, is to be arranged in a square form in a clay soil with an average unconfined compressive strength of  $60 \text{ KN/m}^2$ . Calculate the center to center spacing of the piles for a group efficiency factor 1. Neglect bearing at the tip piles and take adhesion factor of 0.9. [8]
9. What is the best suitability of well foundation? Showing the clear sketch, explain about different components of well foundation. [2+6]
10. Write down the various methods of improving the shear strength of soil by various soil stabilization methods. [4]



Exam.	Regular		
Level	BE	Full Marks	80
Programme	BCE	Pass Marks	32
Year / Part	III / I	Time	3 hrs.

**Subject: - Foundation Engineering (CE602)**

- ✓ Candidates are required to give their answers in their own words as far as practicable.
- ✓ Attempt All questions.
- ✓ The figures in the margin indicate Full Marks.
- ✓ Assume suitable data if necessary.

1. What are the major criteria to be satisfied in the design of a foundation? [2]
2. a) Differentiate between representative and non-representative soil samples. What are the different sampler design parameters? Explain with their physical meaning (No need to write the formulas) [2+5]
- b) How do you prepare the good site investigation reports? [5]
3. a) What is the earthquake effect on earth pressure? What is the order of horizontal strain required to produce active state in (i) coarse grained soil and (ii) Fine grained soil? What are the tentative dimensions of cantilever retaining walls? [1+2+5]
- b) A retaining wall with a smooth vertical back is 8 m high and retains a 2-layered soil having properties as follows: [8]

Depth (m)	C (KN/m <sup>2</sup> )	Φ (degrees)	γ (KN/m <sup>3</sup> )
0-4	10	30	18
4-8	0	34	20

Show the active earth pressure distribution on the back of the retaining wall and its resultant.

4. What are the essential requirements for arching effects? Draw the apparent earth pressure design diagrams recommended by Pecketal (1974) for cuts in sands, firm clay and soft to medium clay. [1+3]
5. What are the different types of cofferdams? What are their relative merits and demerits? [2+2]
6. a) What is the difference among immediate settlements, primary consolidation settlement and secondary compression settlement? Explain the limitations of plate load test. [3+3]
- b) A mat foundation of size 8 m×10 m is resting at a depth of 5 m. The foundation is resting on saturated cohesive soil having undrained cohesion of 50 kPa. The soil has unit weight of 19 KN/m<sup>3</sup>. Find the net safe bearing capacity using Skemton's method. [6]
7. What is compensated foundation? Describe the procedure for the conventional design of raft foundations. [2+4]
8. a) Define negative skin friction in pile. Explain a typical situation where negative skin friction may occur. How does negative skin friction affect load carrying capacity of pile? [4]
- b) A pile group consists of 16 piles is driven into a clay deposit. The piles are arranged in square configuration, i.e 4 piles in each direction. The center to center distances between the piles in both directions are 2.4 m. The length of the pile is 10 m and diameter is 0.8 m. The average undrained shear strength along the upper 5 m length of the pile is 40 KN/m<sup>2</sup> and the average undrained shear strength along the lower 5 m length of the pile is 60 KN/m<sup>2</sup>. If adhesion factor is 0.6 for both layers, determine the ultimate load capacity of the pile group. [8]
9. Explain with clear sketches the various components of well foundations. What are the different methods to analyze the lateral stability of well foundation? What are the different forces acting on well foundation? [4+2+2]
10. What are the different soil improvement techniques? Explain any two of them. [2+2]

Exam.	New Back (2066 & Later Batch)		
Level	BE	Full Marks	80
Programme	BCE	Pass Marks	32
Year / Part	III / I	Time	3 hrs.

**Subject: - Foundation Engineering (CE602)**

- ✓ Candidates are required to give their answers in their own words as far as practicable.
- ✓ Attempt All questions.
- ✓ The figures in the margin indicate Full Marks.
- ✓ Assume suitable data if necessary.

1. a) What is standard penetration test? Write down its procedure. For what purpose can the result of this test be used? How can the standard penetration values be corrected for dilatancy and over burden pressure? [8]
- b) Explain Terzaghi's trap door experiment with neat sketch. A 8 m deep cut in sand with a cut width of 5 m is braced at equal distance of 2 m from the surface at three locations. In the plan the struts are placed at a spacing of 4 m center to center. Using empirical pressure diagram, calculate the design strut loads if the properties of sand is, angle of shearing resistance of  $30^\circ$  and unit weight of  $16 \text{ kN/m}^3$ . [8]
2. a) High steel sheet pile wall with smooth vertical back supports a dry cohesionless soil that weighs  $18 \text{ kN/m}^3$ . The backfill rises from the crest of the wall at an angle of  $20^\circ$  with the horizontal. If the angle of internal friction of backfill materials is  $30^\circ$ , determine the magnitude and point of application of active earth pressure per meter length of the wall. What will be the change in its magnitude and point of application, if water table rises to an elevation of 2 m below the top of the wall? Take the submerged unit weight of the backfill material as  $12 \text{ kN/m}^3$ . [8]
- b) Describe Culmann's graphical method of finding earth pressure for active state and explain how surcharge will affect earth pressure in active states. [8]
3. a) How do you differentiate whether there will be general or local shear failure at your site? An engineer wants to construct a circular footing of 1 m diameter to transfer the load of 1000 kN with the safety factor of 2.5 to a soil strata with an angle of shearing resistance  $30^\circ$ , cohesion  $10 \text{ kN/m}^2$  and unit weight of  $18 \text{ kN/m}^3$ . Suggest the engineer what should be the depth of the footing. Take Terzaghi's bearing capacity factors  $N_c$ ,  $N_q$  and  $N_\gamma$  as 37.2, 22.5 and 19.7 respectively. [4+8]
- b) A mat  $18 \text{ m} \times 22 \text{ m}$  in plan has its base 3 m below the surface of the deposit of clay with a unit weight of  $20 \text{ kN/m}^3$ . The unconfined compressive strength of clay is  $75 \text{ kN/m}^2$ . The factor of safety against bearing capacity failure must be 3. Determine total weight of building plus the foundation the raft can safely support. [4]
4. a) Give a method to determine the bearing capacity of a pile in sandy soil. What is group effect and how will you estimate the capacity of a pile group in sand with neat sketch? Explain the application and limitations of pile load test. [10]
- b) A group of 16 piles of 50 cm diameter is arranged with a center to center spacing of 1.0 m. The piles are 9 m long and are embedded in soft clay with cohesion of  $30 \text{ kN/m}^2$ . Bearing resistance may be neglected for the piles. Adhesion factor is 0.6. Determine the ultimate load capacity of the pile group. Also check the efficiency of the group of pile. [6]
5. a) What are the conditions that demand the improvement of the soil? Write down the different methods of soil improvement techniques. Write down the measures to be taken for sinking the wells and correcting the tilts and shifts occurred during sinking of caissons. [2+2+4]
- b) Determine the depth of embedment and force in tie rod of an anchored sheet pile wall retaining soil bank of height 5 m. The tie rod is located 1 m below the top of the wall. The backfill and the soil below the dredge line is cohesionless. Take  $\phi = 30^\circ$  and soil unit weight as  $18 \text{ kN/m}^3$ . [8]

Exam.	New Back (2066 & Later Batch)		
Level	BE	Full Marks	80
Programme	BCE	Pass Marks	32
Year / Part	III / I	Time	3 hrs.

**Subject: - Foundation Engineering (CE602)**

- ✓ Candidates are required to give their answers in their own words as far as practicable.
- ✓ Attempt All questions.
- ✓ The figures in the margin indicate Full Marks.
- ✓ Assume suitable data if necessary.

1. What are the general requirements of building foundation? What are the points that should be considered while preparing the site investigation report? [2+4]
2. In a core of Kathmandu valley a Geotechnical investigation is to be carried out. As an engineer, recommend the type of drilling and the suitable field tests such that the test data can be used as much as possible. [7]
3. a) Describe the step by step procedure of Culmann's graphical method to determine the active thrust behind the retaining wall supporting the cohesionless backfill carrying the concentrated line load. [6]  
 b) Explain the differences between the Rankine's and Coulomb's earth pressure theory. Determine 'At rest pressure' and its point of application for the following case. Take the unit weight of soil and angle of internal friction above and below water tables as  $17\text{KN/m}^3$  and  $20\text{KN/m}^3$ ,  $30^\circ$  and  $33^\circ$  respectively. [3+6]

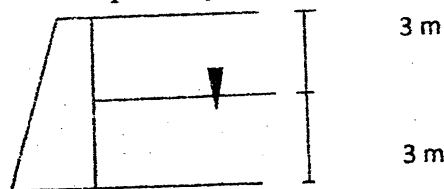

4. What are the bracing systems in braced excavations? Explain deep cuts in soil. [4]
5. What is a cofferdam? Write down the methods of its application. [4]
6. a) Explain how the bearing capacity of soil is affected by the fluctuation of the water table with neat sketch. [6]  
 b) A footing  $3\text{ m} \times 4\text{ m}$  in plan is to be laid at a depth of 1.5 m below ground surface to carry a column load having one way eccentricity of 0.26 m along x direction. Determine the safe bearing capacity if water table is 0.5 m below the ground level. Use Terzaghi's theory. Take  $\phi = 29^\circ$ ,  $C = 20\text{ KN/m}^2$ ,  $N_c = 50$ ,  $N_q = 42$  and  $N_\gamma = 46$ . [10]
7. What are the common types of mat foundation? Write down the concept of compensated foundation. [6]
8. a) Derive the relation for determining the pile load carrying capacity of driven pile in sand by static method. [5]  
 b) Differentiate the following: [2×3]
  - i) Batter pile and Tension pile
  - ii) Individual failure and block failure
  - iii) Drop hammer and steam hammer
9. What is a well foundation? Show all components in a neat sketch. Discuss the remedies for tilt and shift of well foundation. [7]
10. Mention the uses of soil stabilization and describe any one method of soil stabilizations. [4]

Level	BE	Full Marks	50
Programme	BCE	Pass Marks	32
Year / Part	III / I	Time	3 hrs.

**Subject: - Foundation Engineering (CE602)**

- ✓ Candidates are required to give their answers in their own words as far as practicable.
- ✓ Attempt All questions.
- ✓ The figures in the margin indicate Full Marks.
- ✓ Assume suitable data if necessary.

1. Identify the factors influencing the choice of foundation? What are the things that you will consider while preparing the site investigation report? [2+4]
2. Explain the procedure of standard penetration test. [8]
3. a) A retaining wall with smooth vertical back retains sand backfill for a depth of 6 m. The backfill has horizontal surface and has following properties  $C = 0$ ,  $\phi = 28^\circ$ ,  $\gamma = 16 \text{ kN/m}^2$ ,  $\gamma_{\text{sat}} = 20 \text{ kN/m}^3$ . Calculate the magnitude of total thrust against the wall if backfill is fully drained, but the top of wall is restrained against yielding. [10]  
 b) What mathematical procedure is used in checking the stability of retaining wall? [6]
4. a) Determine the loads on the 3 struts as shown in the following figure. The soil is clay having properties of  $c = 40 \text{ KN/m}^2$  and  $\gamma = 19 \text{ KN/m}^3$ . The spacing of the struts along the length of cut is 2.50 m. [4]

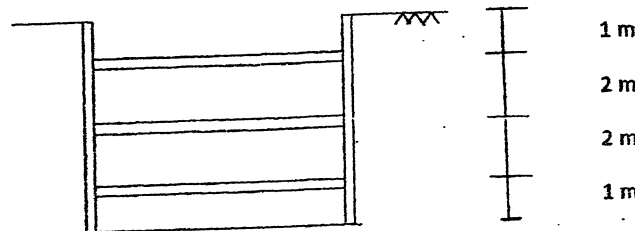

- b) What are the conditions that demand the construction of coffer dams? Write about the cantilever sheet pile wall. [4]
  5. a) What are the possible types of foundation settlement? Explain sand compaction piles. [2+2]  
 b) Determine the allowable bearing capacity of the foundation of size 3 m of square shape from the plate load test data given below with the test plate of thickness 25 mm and size 60 cm. The sub soil consist of moist medium to coarse sand. [8]
- |                 |      |      |      |      |      |      |
|-----------------|------|------|------|------|------|------|
| Load (kg)       | 500  | 1000 | 2000 | 3000 | 4000 | 5000 |
| Settlement (cm) | 0.18 | 0.37 | 0.75 | 1.8  | 5.0  | 18   |
6. a) How the behavior of single pile differs in its group actions? Explain the procedures involved in the determination in the strut loads in braced cut. [2+4]  
 b) Design a friction pile group to carry a load of 3000 KN including the weight of pile cap, at site where the soil is uniform clay to a depth of 20 m, underlain by rock. Average unconfined compressive strength of clay is  $70 \text{ KN/m}^2$ . Take factor of safety of 3 and adhesion factor 0.4. [6]
  7. What are the common type of mat foundation used in civil engineering work? [6]
  8. a) Describe the various components of well foundation with neat sketch. [4]  
 b) A circular well of 6 m external diameter and 4 m internal diameter is embedded to a depth of 15 m subjected to a horizontal force of 800 KN acting at a height of 8 m above the scour level. Determine the allowable total equivalent resisting force due to earth pressure assuming the tilt is about a point above the base. Take  $\gamma_{\text{sat}} = 20 \text{ KN/m}^3$ ,  $\phi = 30^\circ$  and factor of safety for passive resistance = 2.0. [4]
  9. What are sand compaction piles and stone column used for? Write its importance. [4]

Level	BE	Full Marks	80
Programme	BCE	Pass Marks	32
Year / Part	III / I	Time	3 hrs.

**Subject: - Foundation Engineering (CE602)**

- ✓ Candidates are required to give their answers in their own words as far as practicable.
- ✓ Attempt All questions.
- ✓ The figures in the margin indicate Full Marks.
- ✓ Assume suitable data if necessary.

1. How do you select the type of footing? Describe preloading in detail. [2+4]
2. What is pressure meter test (PMT)? How it is carried out in the field? [8]
3. a) Check the stability of the retaining wall shown below with the following given parameters. Unit weight of the concrete is  $25 \text{ KN/m}^3$ ,  $\gamma = 18 \text{ KN/m}^3$ ,  $\gamma_{\text{sat}} = 20 \text{ KN/m}^3$ ,  $\gamma_w = 10 \text{ KN/m}^3$ ,  $\phi = 30^\circ$ ,  $\delta = 2\phi/3$ , the ultimate bearing capacity of soil is  $550 \text{ KN/m}^2$ . [10]

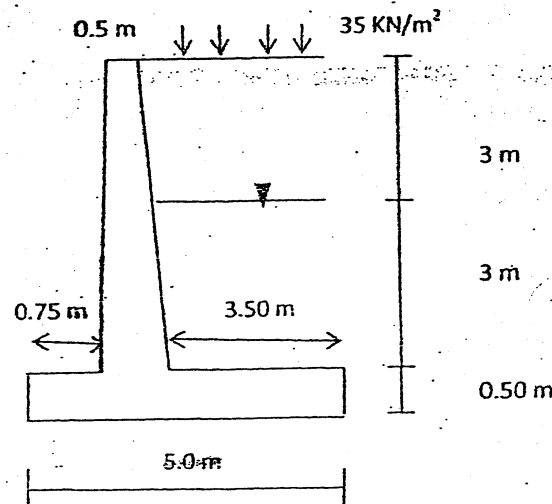

- b) Explain the trial wedge method for determining the active earth pressure with neat sketch. [6]
4. a) Why arching in soil is important? Write down the assumption made by Cain's theory. [4]
- b) A 2.5 m deep excavation of trench is carried out in sand and supported by cantilever sheet pile wall. The water table is at both sides of sheet pile wall is found at bottom of excavation,  $\gamma_{\text{bulk}} = 18 \text{ KN/m}^3$ ,  $\gamma_{\text{sat}} = 20 \text{ KN/m}^3$ ,  $\phi = 35^\circ$ , factor of safety for passive resistance is 2. Determine the required depth of embedment of sheet pile. [4]
5. a) How does water table influence the bearing capacity of soil? Explain with sketch. [4]
- b) A square footing is designed to carry a load of 4500 KN. If the depth of foundation is 3 m. Determine the suitable size of foundation. The water table is at 0.8 m below ground level. Use Terzaghi's theory, take  $\phi = 25^\circ$ ,  $\gamma = 16 \text{ KN/m}^3$ ,  $\gamma_{\text{sat}} = 19 \text{ KN/m}^3$ ,  $N_c = 14.8$ ,  $N_q = 5.6$ ,  $N_\sigma = 3.2$ ,  $C = 20 \text{ KN/m}^2$ . [8]
6. a) Derive the static pile load formula for the driven pile. [6]
- b) A group of 9 piles, 12 m long and 250 mm in diameter is to be arranged in a square form in a clay soil with an average unconfined compressive strength of  $60 \text{ KN/m}^2$ . Work out the center to center spacing of the piles for a group efficiency factor of 1.0. Neglect bearing at the tip of the piles. Take adhesion factor as 0.90. [6]
7. Explain compensated foundation and is it possible to construct a fully compensated foundation. [6]
8. Describe well foundation with a neat sketch. At what circumstances well foundation is proposed? [6+2]
9. What are the different method of improving the bearing capacity of weak soil. [4]

Exam.	Regimen		
Level	BE	Full Marks	80
Programme	BCE	Pass Marks	32
Year / Part	III / I	Time	3 hrs.

**Subject: - Foundation Engineering (CE602)**

- ✓ Candidates are required to give their answers in their own words as far as practicable.
- ✓ Attempt All questions.
- ✓ The figures in the margin indicate Full Marks.
- ✓ Assume suitable data if necessary.

1. List out the factors affecting the type of foundation. [2]
2. a) What are the different types of sampler to obtain undisturbed soil samples? Describe any one procedure of obtaining undisturbed sample. [6]
- b) Explain and discuss the various methods of boring required for subsoil exploration. [6]
3. a) Derive an expression for the determination of factor of safety against bottom heave in a soft clayey soil. [8]
- b) A 6 m high retaining wall supports 5 m sand ( $\gamma = 18 \text{ KN/m}^3$ ,  $\phi = 30^\circ$ ,  $C = 0$ ) overlying saturated sandy clay ( $\gamma = 19.5 \text{ KN/m}^3$ ,  $\phi = 36^\circ$ ,  $C = 16 \text{ KN/m}^2$ ). The ground water level is at the upper surface of sand. Determine the Rankine's active force per unit length of the wall and the location of the thrust, assuming that the retaining wall can yield sufficiently to develop an active state. [8]
4. What are cofferdams? Write their significance. How can the earth pressure against bracing in cuts be determined? [8]
5. a) What is the effect of water table on bearing capacity of soil as per Terzaghi's general bearing capacity equation for local shear failure? [4]
- b) A 1.8 m square column in foundation at a depth of 1.8 m in sand, for which the corrected N-value is 24. The water table is at a depth of 2.7 m. Determine the net allowable bearing pressure for a permissible settlement of 40 mm and a factor of safety of 3 against shear failure. [8]
6. What are the different types of mat foundation? How can the bearing capacity be determined for the mat foundation? [8]
7. What are the functions of pile foundation? Determine the group efficiency of a rectangular group of piles with 4 rows, 3 piles per row, the uniform pile spacing being 3 times the pile diameter. If the individual pile capacity is 100 KN, what is the group capacity according to this concept? [2+8]
8. How will you decide the depth of well foundation? Describe the possible techniques to eliminate the tilt and shift of well during sinking. [8]
9. What do you mean by preloading? Mention the advantage of preloading and at which condition do you refer? [4]

\*\*\*



06 TRIBHUVAN UNIVERSITY  
INSTITUTE OF ENGINEERING  
Examination Control Division  
2070 Ashad

Exam.	New Back (2066 & Later Batch)		
Level	BE	Full Marks	80
Programme	BCE	Pass Marks	32
Year / Part	III / I	Time	3 hrs.

*Subject: - Foundation Engineering (CE602)*

- ✓ Candidates are required to give their answers in their own words as far as practicable.
- ✓ Attempt All questions.
- ✓ The figures in the margin indicate Full Marks.
- ✓ Assume suitable data if necessary.

1. What are the different types of foundations? [2]
2. a) How would you decide the depth of exploration and the lateral extent of the investigation? [4]  
b) What is pressure meter test (PMT)? How is it carried out in the field? [8]
3. a) Explain the trial wedge method for determining the active earth pressure with neat sketch. [8]  
b) A retaining wall 6 m high, vertical back, supports a saturated clay soil with a horizontal surface. The properties of the back fill are:  $\phi_u = 0$ ,  $C_u = 35 \text{ kN/m}^2$  and  $\gamma = 17 \text{ kN/m}^3$ . Assuming the back of the wall to be smooth, determine: the total active thrust against the wall and its point of application. [8]
4. Why arching in soil is important to be studied in geotechnical engineering? Explain the different theories that have been classified by Terzaghi. Derive the expression of finding depth of dredge for cantilever sheet pile using simplified method. [4+4]
5. a) What are the principles differences between Prandtl's bearing capacity theory and Terzaghi's bearing capacity theory? [4]  
b) A square footing is to be designed to carry a load of 6000KN. If the depth of foundation is 2m, determine the suitable size of foundation. The water table is at 0.8 m below ground level. Use Terzaghi's theory. Take  $\phi = 25^\circ$ ,  $\gamma = 16 \text{ KN/m}^3$ ,  $\gamma_{\text{sat}} = 19 \text{ KN/m}^3$ ,  $C = 20 \text{ KN/m}^2$ ,  $N_c = 14.8$ ,  $N_q = 5.6$ ,  $N_\gamma = 3.2$ . [8]
6. The 20 m  $\times$  30 m size mat is constructed at 3.5 m depth having basement for underground parking. The site consists of highly compressible saturated clay having cohesion of 30  $\text{KN/m}^2$ . If the mat carries the total load of 5700 KN. Calculate the factor of safety. [8]
7. What is laterally loaded pile? A circular pile group of 16 piles penetrates through a unconsolidated soil of 3.5 m depth. The diameter of circular pile is 60 cm and piles spacing 800 cm. The average unconfined compressive strength of the material is 60  $\text{KN/m}^2$  and the unit weight of soil is 16  $\text{KN/m}^3$ . Compute the negative skin friction on the group. Take adhesion factor = 1. [2+8]
8. What is a wall foundation? Write down the operation involved in sinking the well foundation. [8]
9. Write down the different methods of improving the bearing capacity of weak soils. [4]

\*\*\*



Exam.	Back		
Level	BE	Full Marks	80
Programme	BCE	Pass Marks	32
Year / Part	III / II	Time	3 hrs.

*Subject: - Foundation Engineering*

- ✓ Candidates are required to give their answers in their own words as far as practicable.
- ✓ Attempt any Five questions.
- ✓ The figures in the margin indicate Full Marks.
- ✓ Assume suitable data if necessary.

1. a) What are the various steps considered in the planning of sub surface exploration Programme? Describe the standard penetration test. In what way is it useful in foundation design? [3+4+1]
- b) If a soil deposit happens to be silty clay (saturated) with a value of  $q_c = 88\text{kg/cm}^2$ , determine the unconfined compressive strength of clay at a depth of 6.5m. The unit weight of soil at that particular depth is  $19.5\text{KN/m}^3$ . What would be the unconfined compressive strength if the overburden pressure is discarded? [8]
2. a) What is Coulomb's wedge theory of earth pressure? Derive the condition for obtaining the maximum active earth pressure. [2+6]
- b) A masonry retaining wall of trapezoidal section with the vertical face on the earth side is 1.5m wide at the top and 3.5m wide at the base and is 5.0m high. It retains a sand fill sloping at 2 horizontal to 1 vertical. The unit weight of sand is  $18\text{KN/m}^3$  and  $\phi = 30^\circ$ . Find the maximum and minimum pressure at the base of the wall assuming the unit weight of masonry as  $23\text{KN/m}^3$ . [8]
3. a) What are the assumptions made in Terzaghi's analysis of bearing capacity of a continuous footing? Describe clearly the effect of ground water table on the safe bearing capacity above, below and at the base of foundation. [2+6]
- b) A square footing located at a depth of 1.5m from the ground surface carries a column load of 150KN. The soil is submerged having an effective unit weight of  $11\text{KN/m}^3$  and an angle of shearing resistance ( $\phi$ ) of  $30^\circ$ . Find the size of the footing, if factor of safety is 3. Use Terzaghi theory, for  $\phi = 30^\circ$ ,  $N_q = 10$ ,  $N_\gamma = 6$ . [8]
4. a) What are the reasons that could lead to the development of negative skin friction' in a pile foundation? What inputs are required for the estimation of settlement of a group of friction piles in clay? Mention the assumptions made. [3+5]
- b) A 30 cm square pile, 15m long, is driven in a deposit of medium dense sand ( $\phi = 36^\circ$ ,  $N_\gamma = 40$  and  $N_q = 42$ ). The unit weight of sand is  $15\text{KN/m}^3$ . What is the allowable load with a factor of safety of 3? Assume lateral earth pressure coefficient = 0.6. [6]
5. a) What is a pier foundation? Explain the different types of piers with its advantages and disadvantages. Describe the different parts of well foundation with neat sketch. [1+3+4]
- b) An excavation of 6m deep is to be carried out in a cohesionless soil having a unit weight of  $21\text{KN/m}^3$  and  $\phi = 36^\circ$ . To support the soil, cantilever sheet pile walls are driven in to the ground prior to excavation. Determine the depth of penetration needed for the sheet pile to retain the backfill. The water table is below the base of the sheet pile. [8]
6. Write short notes on: [4x4]
- a) Types of mat foundations and their uses
  - b) Underpinning
  - c) Components parts of well foundations
  - d) Types of cofferdams and their uses

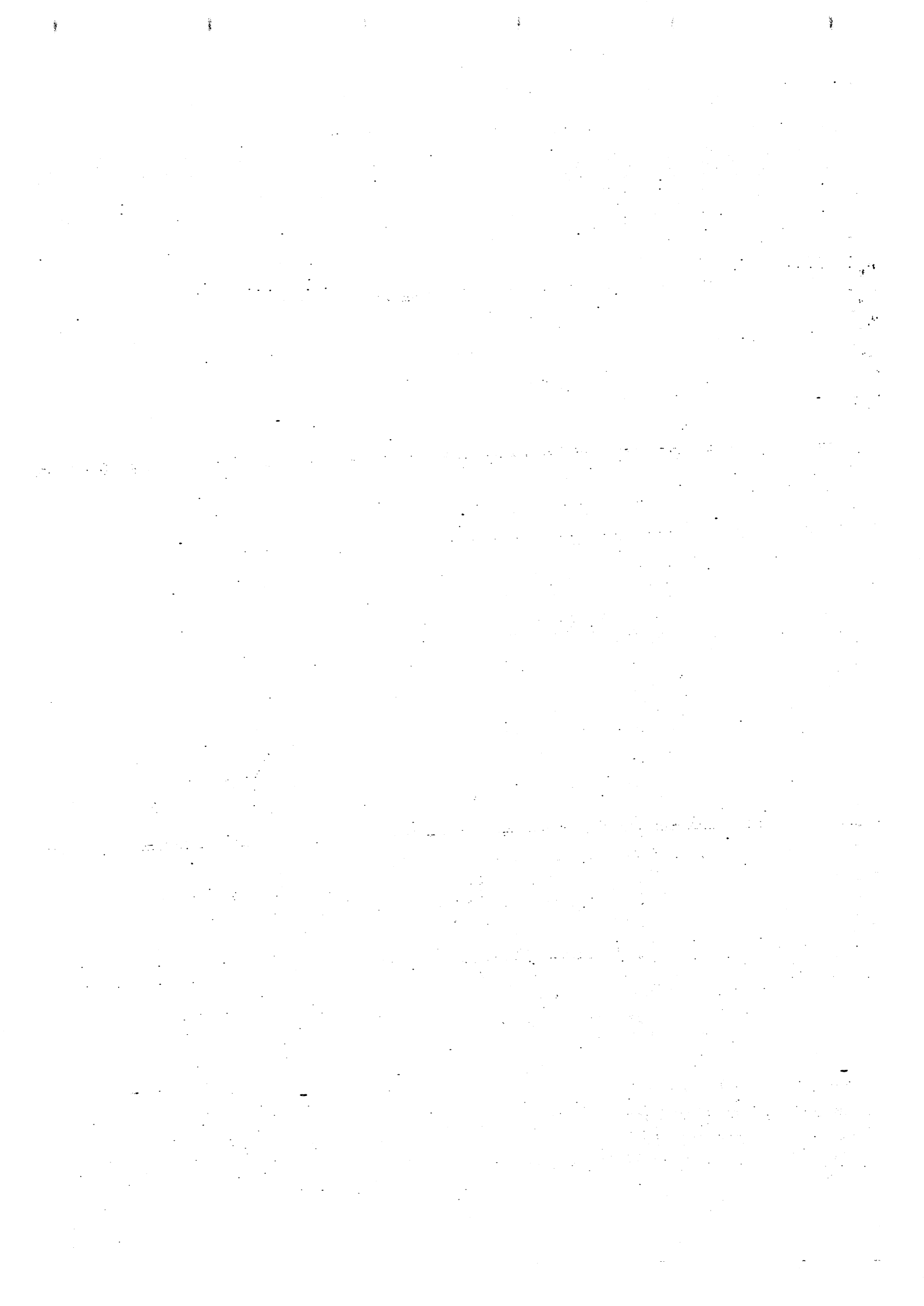

Exam.	Regular		
Level	BE	Full Marks	80
Programme	BCE	Pass Marks	32
Year / Part	III / I	Time	3 hrs.

*Subject: - Foundation Engineering (CE 602)*

- ✓ Candidates are required to give their answers in their own words as far as practicable.
- ✓ Attempt any all questions.
- ✓ The figures in the margin indicate Full Marks.
- ✓ Assume suitable data if necessary.

1. a) What is an undisturbed sample of soil? Describe, how you can obtain undisturbed sample from the site. [2+6]
- b) Describe the major advantages and disadvantages of Pressuremeter Test over the other methods of soil exploration. Mention the key points that should be considered to perform the Pressuremeter Test at a particular site. [3+5]
2. a) What are the differences between Coulomb's theory and Rankine's theory of earth pressure? Describe the effect on wall movement on earth pressure. [4+4]
- b) A cut 3.5m wide, 7m deep is proposed in a cohesionless deposit ( $\phi = 35^\circ$ ). Assuming the first row of struts to be located at 0.6m below the ground surface and spacing between struts as 2m, calculate the maximum strut load. Assume the horizontal spacing of struts as 3.5m,  $\gamma = 21\text{kN/m}^3$  and  $\delta = 15^\circ$ . [8]
3. a) What are the theories on the bearing capacity of soil? Derive the expression for ultimate bearing capacity of soil as per Terzaghi's analysis. [1+7]
- b) The sides of an excavation 3m deep in sand are to be supported by cantilever sheet pile walls. The water table is 1.5m below from the bottom of excavation. The sand has saturated unit weight of  $20\text{kN/m}^3$  and unit weight of  $17\text{kN/m}^3$  above the water table and  $\phi = 36^\circ$ . Determine the depth of penetration of the piling below the bottom of excavation to give a factor of safety of 2.0 with respect to passive resistance. [8]
4. a) What is negative skin friction? Describe the circumstances on which pile foundation has to be selected. Also describe the selection procedure of pile type. [2+3+3]
- b) A footing of  $2\text{m} \times 3\text{m}$  in plan is founded 1.5m below the ground level in clay having angle of repose =  $36^\circ$ ,  $c = 10\text{kPa}$ , what will be the allowable load which can be carried by the footing if the load is eccentrically applied with eccentricity along X and Y direction as 0.25m and 0.35m respectively. The centre of footing in plan is taken as origin. The water table is located 1m below the ground level. Assume soil above water table is as dry. Take dry and saturated unit weight of clay as  $16\text{kN/m}^3$  and  $20\text{kN/m}^3$  respectively. Take  $N_c = 50$ ,  $N_q = 42$  and  $N_\gamma = 46$ . [8]
5. a) Is it necessary to analyse the lateral stability of well foundation? If so, describe why and how it is to be carried out. [2+6]
- b) A RCC pile weighing 41.2 kN(including weight of helmet and dolly) is driven by drop hammer weighing 49kN and having an effective fall of 1m. The average settlement per blow is 14mm. The total elastic compression is 12mm. Assuming the coefficient of restitution as 0.2 and FOS as 2.5, calculate the ultimate load and allowable load for the pile. [8]

Exam.	Regular / Back		
Level	BE	Full Marks	80
Programme	BCE	Pass Marks	32
Year / Part	III / II	Time	3 hrs.

**Subject: - Foundation Engineering**

- ✓ Candidates are required to give their answers in their own words as far as practicable.
- ✓ Attempt any Five questions.
- ✓ The figures in the margin indicate Full Marks.
- ✓ Assume suitable data if necessary.

1. a) What are the various steps considered in the planning of sub-surface exploration programme? Describe the standard penetration test. In what way is it useful in foundation design? [3+4+1]
- b) A SPT was performed at a depth of 20m in a dense sand deposit with a unit weight of  $17.5 \text{ kN/m}^3$ . If the observed N-value is 48, what is the N-value corrected for overburden and dilatancy? The inner diameters of a sampling tube and that of a cutting edge are 70mm and 68mm respectively, their outer diameters are 72 and 74mm respectively. Determine the inside clearance, outside clearance and area ratio of the sampler. [4+4]
- ✓ a) A masonry retaining wall of trapezoidal section with the vertical face on the earth side is 1.5m wide at the top and 3.5m wide at the base and is 5.0m high. It retains a sand fill sloping at 2 horizontal to 1 vertical above the top horizontal surface of wall. The unit weight of sand is  $18 \text{ kN/m}^3$  and  $\phi = 30^\circ$ . Find the maximum and minimum pressure at the base of the wall assuming the unit weight of masonry as  $23 \text{ kN/m}^3$ . [8]
- b) Describe Culmann's graphical method of finding earth pressure for active and passive cases. Assume sloping surface above the top horizontal surface of wall. [8]
3. a) What are the assumptions made in Terzaghi's analysis of bearing capacity of a continuous footing? Bring out clearly the effect of ground water table on the safe bearing capacity above, below and at the base of foundation. [4+4]
- b) A footing, 2m square, is founded at a depth of 1.5 m in a sand deposit, for which the corrected value of N is 27. The water table is at a depth of 2m from the surface. Determine the net allowable bearing pressure, using both Teng's and Bowles' empirical relationships, if the permissible settlement is 40mm and a factor of safety of 3 is desired against shear failure. [8]
4. a) Derive a method to determine the bearing capacity of a pile in C and  $\phi$  soil. What is group effect and how will you estimate the capacity of a pile group in C and  $\phi$  soil, explain with neat sketch? Explain the application and limitations of pile load test. [3+4+3]
- b) A 30cm square pile, 15m long, is driven in a deposit of medium dense sand ( $\phi = 36^\circ$ ,  $N_y = 40$  and  $N_q = 42$ ). The unit weight of sand is  $15 \text{ kN/m}^3$ . What is the allowable load with a factor of safety of 3? [6]
5. a) What is a pier foundation? Explain the different types of caissons with their advantages and disadvantages. Describe the different parts of well foundation with neat sketch. [1+3+4]

- b) A building is supported symmetrically on four columns, spaced at 4.5m c/c. At the chosen depth of 2m, the allowable bearing capacity is  $300 \text{ kN/m}^2$ ,  $\gamma = 18 \text{ kN/m}^3$ . Proportion the footings for equal settlement. The column loads are given below: [8]

Column No.	1	2	3	4
DL(kN)	200	350	250	270
LL(kN)	200	400	200	270

6. a) Discuss the different methods of improving the bearing capacity of weak soils. Describe the different steps involved in the process of soil stabilization using cement as the additive. [8]
- b) Determine the depth of embedment of an anchored steel pile wall using free earth support method in a deposit of sand having  $C = 0$ ,  $\phi = 32^\circ$ ,  $\gamma_{\text{sat}} = 22 \text{ kN/m}^3$  and  $\gamma_{\text{dry}} = 17 \text{ kN/m}^3$ . The water table is 2m below the ground surface. The height of the wall above the dredge line is 3m. Use simplified method. [8]

\*\*\*





TRIBHUVAN UNIVERSITY  
INSTITUTE OF ENGINEERING  
**Examination Control Division**  
2079 Bhadra

Exam.	Regular		
Level	BE	Full Marks	30
Programme	BCE, BME, BAM, BIE, BAS	Pass Marks	32
Year / Part	III / I	Time	3 hrs.

**Subject: - Numerical Methods (SH 603)**

- ✓ Candidates are required to give their answers in their own words as far as practicable.
- ✓ Attempt All questions.
- ✓ The figures in the margin indicate Full Marks.
- ✓ Assume suitable data if necessary.

1. Derive the iteration formula of Newton-Raphson method for approximating a real root of a non-linear equation using Taylor's series expansion. [4]
2. Write algorithm/pseudo-code to find a real root of a non-linear equations using bisection method. [6]
3. Using the Secant Method, find a real root of the equation  $xe^x = \cos x$  correct to three decimal places. [6]
4. Find the inverse of the following matrix using the Gauss Jordan Method: [8]

$$\begin{bmatrix} 1 & 3 & 6 \\ 2 & -1 & 1 \\ 4 & -2 & 3 \end{bmatrix}$$

5. Find the largest eigen value and corresponding vector of the following matrix by power method. [8]

$$\begin{bmatrix} 5 & -2 & 0 \\ -2 & 5 & -2 \\ 0 & -2 & 5 \end{bmatrix}$$

6. Using the least square method, fit a second degree polynomial to the following data: [8]

x	0	1	2	3	4
y	1	1.8	1.3	2.5	7.3

7. Using natural cubic spline interpolation technique, evaluate  $y(5.5)$  from the following data. [8]

x	2	4	6	8	10
y	2	5	7	3	4

8. Write program code in C/C++ to evaluate a definite integral of a given function using Simpson's Three-Eighth rule. [4]
9. Use Romberg's method to compute the following integral, correct to 3 decimal places. [6]

$$\int_1^2 \frac{1 + \cos x}{1 + \sin x} dx$$

10. Solve the following initial value problem for  $x = 0(1)3$  using Runge-Kutta 2<sup>nd</sup> order method. [6]

$$\frac{dy}{dx} = \sin(x) + \cos(x) - y, y(0) = 1$$

11. Solve the following boundary value problem using finite difference method taking a step-size of 0.5. [8]

$$y'' = 2y' - y + x \text{ subject to boundary conditions } y(0) = 1 \text{ and } y(2) = 1$$

12. Solve the Laplace equation  $u_{xx} + u_{yy} = 0$  for a square mesh with the following boundary information. [8]

$$\begin{aligned} 0 \leq x \leq 3, & \quad 0 \leq y \leq 3, & \quad \Delta x = h = 1, & \quad \Delta y = k = 1 \\ u(x, 0) = 200x, & \quad u(0, y) = 200y & \quad u(3, y) = 200(3 - y), & \quad u(x, 3) = 200(3 - x) \end{aligned}$$



Exam.	Back	
Level	BE	Full Marks 80
Programme	BCE, BME, BAM, BIE, BAS	Pass Marks 32
Year / Part	III / I	Time 3 hrs.

**Subject: - Numerical Methods (SH 603)**

- ✓ Candidates are required to give their answers in their own words as far as practicable.
- ✓ Attempt All questions.
- ✓ The figures in the margin indicate Full Marks.
- ✓ Assume suitable data if necessary.

1. Discuss the importance of Numerical methods in science and engineering. [4]
2. Write an algorithm to find a real root of a non linear equation using scant method. [6]
3. Using Newton- Raphson method, find the positive root of  $\cos x = 1.3x$  correct to six decimal places. [6]
4. Solve the following system of equations using LU Factorization method [8]

$$x + 2y - z = 2$$

$$x - 3y + 2z = 1$$

$$2x + 4y + 3z = 19$$

5. Find the largest eigen value and corresponding given vector of the following matrix [8]

$$\begin{bmatrix} 2 & 3 & 4 \\ 3 & 5 & -2 \\ 4 & -2 & 2 \end{bmatrix}$$

6. Find the best fit in the form  $y = ax^2 + bx + c$  using least square approximation from the following data [8]

x	2	3	4	5	6	7	8
y	40	36	53	60	45	43	38

7. Using the appropriate interpolation formula, approximate the values  $y(1.5)$  and  $y(7.8)$  from the following data: [8]

x	1	2	3	4	5	6	7	8
y	33	39	60	25	22	30	45	56

8. Derive the Newton-Cotes Quadrature formula and use it to derive the formula for Simpson's 1/3 rule. [6]
9. Write a program in C/C++ to solve a first order linear differential equation (Initial Value Problem) using RK-4 method. [6]
10. Approximate the following integral using 3-point Gaussian Quadrature formula. [4]

$$\int_1^2 e^{\sin x} dx.$$

11. Solve the following boundary value problem using the finite difference method by dividing the interval into the four subintervals. [8]

$$y'' + 3y' - \cos(x) - y = 0, \quad y(0) = 2, \quad y(2) = 3$$

12. Derive the recurrence relation for solving Poisson's equation and hence use it to solve the Poisson's equation  $u_{xx} + u_{yy} = 729x^2y^2$  on a square grid with  $0 \leq x \leq 1$  and  $0 \leq y \leq 1$  and given that  $u = 0$  on the boundary (consider step size  $h = \frac{1}{3}$ ). [8]



Exam.	Regular		
Level	BE	Full Marks	80
Programme	BCE, BME, BAM, BIE, BAS	Pass Marks	32
Year / Part	III / 1	Time	3 hrs.

**Subject: - Numerical Methods (SH 603)**

- ✓ Candidates are required to give their answers in their own words as far as practicable.
- ✓ Attempt All questions.
- ✓ The figures in the margin indicate Full Marks.
- ✓ Assume suitable data if necessary.

1. Define absolute, relative and percentage errors and hence find the absolute and relative errors if the number  $x = 0.004997$  is rounded off to three decimal places. [4]
2. Write an algorithm to find a real root of a non linear equation using secant method. [6]
3. Find a real root of  $3 - e^x + \cos x = 0$  correct to three places of decimal using Bisection method. [6]
4. Solve the following system of linear equations using Gauss-seidel method, correct to 3 decimal places. [8]

$$2a_1 + 6a_3 - 3a_4 - 31 = 0$$

$$6a_1 + 2a_4 - 14 = 0$$

$$-3a_1 + 5a_2 - 9 = 0$$

$$2a_1 + a_2 - 5a_3 + 9a_4 + 9 = 0$$

5. Using Power method evaluate the dominant eigen value and its corresponding eigen vector of following matrix. [8]

$$\begin{bmatrix} -15 & 4 & 3 \\ 10 & -12 & 6 \\ 20 & -4 & 2 \end{bmatrix}$$

6. Fit the following set data to a parabola  $y = a + bx + cx^2$  [8]

x	1	2	3	4	5	6
y	8.5	10	9.5	7	2.5	-4

7. Approximate  $y(3)$  and  $y(12)$  using appropriate interpolation formula for the following data. [8]

x	4	5	6	7	8	9	10	11
y	18.5	23.5	29.5	33.2	39.5	43.3	47.2	52.2

8. Solve  $\frac{dy}{dx} = \frac{x^2 - y^2}{x^2 + y^2}$  to approximate  $y(0.4)$  subject to condition  $y(0) = 1$  taking step size  $h = 0.2$ . [4]

9. Using interpolation formula, derive Newton-cotes quadrature formula and hence use it to derive composite trapezoidal rule for integration. [6]

10. The distance travelled by a vehicle at intervals of 2 minutes are given as: [4]

t (minutes)	2	4	6	8	10	12	14
distance (k.m)	0.25	1	2.2	4	6.5	8.5	11

Calculate velocity and acceleration at  $t = 4$  minutes.

11. Solve the Boundary Value Problem using Finite Difference Method  $y'' + xy' + y = 3x^2 + 2$ ,  $y(0) = 0$  and  $y(1) = 1$ . Take  $h = 0.25$ . [8]

12. Derive recurrence formula for solving a Poisson's equation using it solve the following Poisson's equation:

$$u_{xx} + u_{yy} = -10(x^2 + y^2 + 10) \text{ over the square mesh } 0 \leq x \leq 3, 0 \leq y \leq 3 \text{ with } u(x, y) = 0 \text{ on the boundary and mesh length } h = k = 1$$

TRIBHUVAN UNIVERSITY  
 INSTITUTE OF ENGINEERING  
**Examination Control Division**  
 2078 Kartik

Exam.	Back		
	Level	BE	Full Marks
			80
Programme	BCE, BME, EAM, BIE	Pass Marks	32
Year / Part	III / I	Time	3 hrs.

**Subject: - Numerical Methods (SH 603)**

- ✓ Candidates are required to give their answers in their own words as far as practicable.
- ✓ Attempt **All** questions.
- ✓ The figures in the margin indicate **Full Marks**.
- ✓ Assume suitable data if necessary.

- Discuss the significance of Numerical Methods in the field of Engineering in modern day context. [4]
- State the condition for which fixed point iteration method converges. Solve the equation  $x^3 + x^2 - 3 = 0$  correct to four decimal places using fixed point iteration method. [2+4]
- Write a pseudo-code to find a real root of a non linear equation using Secant method. [6]
- Solve the following system of equations using Gauss Elimination with Partial Pivoting. [8]

$$\begin{aligned}
 -x + 2y + 3z + w &= 3 \\
 2x - 4y + z + 2w &= -1 \\
 -3x + 8y + 4z - w &= 6 \\
 x + 4y + 7z - 2w &= -4
 \end{aligned}$$

- Obtain the dominant Eigen value and its corresponding vector of following matrix using Power Method. [8]

$$\begin{pmatrix}
 1 & 3 & 5 \\
 3 & 1 & 3 \\
 5 & 3 & 1
 \end{pmatrix}$$

- For the following set of data, fit a second degree polynomial function using least square method. [8]

x	0.5	1	1.5	4.5	6.5	7.5
f(x)	2.5	2.7	3.5	6.5	5.4	4.8

- From the following table, evaluate  $y(4.3)$  using cubic spline interpolation technique. [8]

x	1	3	5	7	9
y	3.82	7.59	9.65	8.92	11.10

- Evaluate the following integral using 3-point Gaussian quadrature formula. [4]

$$I = \int_{-1}^1 \frac{e^x - \sin x}{1+x^2} dx$$

- Use following table of data to estimate velocity and acceleration at time  $t = 9$  sec. [6]

Time in second	5	6	7	8	9
Distance travelled (in meter)	10	14.5	19.5	25.5	32

- Write a program in any high level language (C/C++) to solve a second order differential equation (IVP) using classical RK-4 method. [6]

- Solve the following boundary value problem using finite difference method by dividing the interval into four sub-intervals. [8]

$$y'' = \sin x + 3y - y', \text{ with } y(0) = 1 \text{ and } y(2) = 5$$

- Solve the Laplace equation  $\nabla^2 u = 0$  over the given square grid. [8]

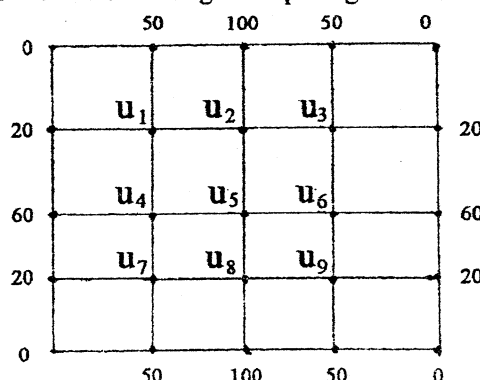

TRIBHUVAN UNIVERSITY  
INSTITUTE OF ENGINEERING  
**Examination Control Division**  
2076 Chaitra

Exam.	Regular		
Level	BE	Full Marks	80
Programme	BCE, BME, BAM, BIE	Pass Marks	32
Year / Part	III / I	Time	3 hrs.

**Subject: - Numerical Methods (SH 603)**

- ✓ Candidates are required to give their answers in their own words as far as practicable.
- ✓ Attempt All questions.
- ✓ The figures in the margin indicate Full Marks.
- ✓ Assume suitable data if necessary.

1. What are the importances of Numerical Methods in the field of science and engineering? [4]
2. Write an algorithm to find a real root of a non-linear equation using Bisection method. [6]
3. What are the limitations of Newton- Raphson method? Using this method, find the real root of the equation  $\cos x - 3x + 1 = 0$ , correct to four decimal places. [6]
4. Solve the following system of equations by LU factorization method. [8]

$$\begin{aligned} 2x_1 + x_2 + 5x_3 &= 25 \\ x_1 - x_2 + 3x_3 &= 13 \\ x_2 - 2x_1 + 4x_3 &= 13 \end{aligned}$$

5. Find the largest eigenvalue and corresponding eigen vector of the matrix  $A = \begin{bmatrix} 2 & -2 & 4 \\ 2 & 3 & 2 \\ -1 & 1 & 1 \end{bmatrix}$  using power method. [8]

6. Fit a curve  $y = ax^b$  to the following data: [8]

x	1	2	3	4	5
y	0.5	2	4.5	8	12.5

7. Estimate  $y(4)$  using cubic spline interpolation technique from the following data. [8]

x	3	5	7	9	11
y	6	9	12	9	6

8. Evaluate  $\int_{-1}^2 e^{-x^2} dx$  using Gaussion 3 - point formula. [4]
9. Derive the general Newton-cotes quadrature formula and use it to obtain simpson's 1/3 formula. [6]
10. Write a pseudo - code to solve first order differential equation using RK-4 method. [4]
11. Solve the following boundary value problem using finite difference method by dividing the interval into four sub intervals. [8]

$$y'' + 3y' - y = \cos x \quad y(0) = 2 \text{ and } y(2) = 3$$

12. Solve the elliptic equation  $u_{xx} + u_{yy} = 0$  for the following square mesh with the boundary values as shown. [10]

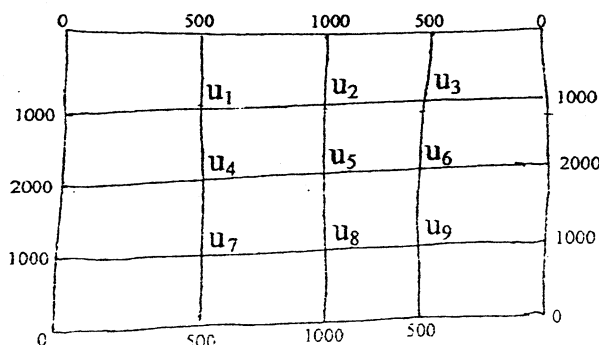

Exam.	Back		
	Level	BE	Full Marks
Programme	BCE, BME, BAM, BIE	Pass Marks	32
Year / Part	III / I	Time	3 hrs.

**Subject: - Numerical Methods (SH 603)**

- ✓ Candidates are required to give their answers in their own words as far as practicable.
- ✓ Attempt **All** questions.
- ✓ The figures in the margin indicate **Full Marks**.
- ✓ Assume suitable data if necessary.

1. Using finite difference table, show that the following data satisfies a cubic polynomial. [4]

x	0	1	2	3	4
y	-8	0	26	88	204

2. Write an algorithm/pseudo-code to find a real root of a non-linear equation using Bisection method. [6]

3. Find a real root of the equation  $3x + \sin(x) - e^x = 0$  correct to 3 decimals using False Position (Regular-Falsi) method. [6]

4. Compute the inverse of the following matrix using the Gauss-Jordan Method. [8]

9	9	8
7	8	7
6	8	8

5. Find the largest Eigen value and corresponding Eigen vector of the matrix  $\begin{bmatrix} 1 & 4 & 4 \\ 4 & 1 & 8 \\ 4 & 8 & 1 \end{bmatrix}$  using power method. [8]

6. Using the Least Squares Method, fit a second-order polynomial  $y = ax^2 + bx + c$  to the following set of data: [8]

x	1.0	1.50	2.0	2.5
y	0.75	1.25	1.45	1.25

7. Interpolate  $y(24)$  from the following data using natural cubic spline. [8]

x	10	15	20	25	30
y	22	31	28	25	26

8. Using Gauss-Legendre 3-point formula, evaluate:  $\int_1^3 (x \sin x + \log_e x) dx$  [6]

9. A rod is rotating in a plane. The following table gives the angle  $\theta$  (radian) through which the rod has turned for various of time  $t$  seconds. [4]

t	1.0	1.2	1.4	1.6	1.8	1.9	2.0
$\theta$	2.10	2.31	2.52	2.85	3.24	3.95	4.31

Calculate the angular velocity of the rod when  $t=1.1$  sec.

10. Write the pseudo-code for solving a 1<sup>st</sup> order ordinary differential equation using Runge-Kutta 4<sup>th</sup> order method. [6]

11. Solve the differential equation  $y'' + xy' - y = x$ ;  $y(0) = 1$ ;  $y(1) = 0$  using finite difference method by dividing four sub-intervals. [8]

12. Solve  $U_{xx} + U_{yy} = 0$  for the square mesh bounded by  $0 \leq x \leq 4$ ;  $0 \leq y \leq 4$  and the boundary conditions  $u(0,y) = 150$ ,  $u(4,y) = 150$ ,  $u(x,0) = 100$ ,  $u(x,4) = 100$ ;  $0 < x < 4$ ;  $0 \leq y \leq 4$ . Find the values of  $u(i,j)$ ,  $i = 1, 2, 3$  correct to 3 places of decimals. [8]



**TRIBHUVAN UNIVERSITY**  
**INSTITUTE OF ENGINEERING**  
**Examination Control Division**  
**2075 Chaitra**

Exam.	Regular / Back		
	Level	BE	Full Marks
Programme	BCE, BME, BAM, BIE	Pass Marks	32
Year / Part	III / I	Time	3 hrs.

**Subject: - Numerical Methods (SH 603)**

- ✓ Candidates are required to give their answers in their own words as far as practicable.
- ✓ Attempt All questions.
- ✓ The figures in the margin indicate Full Marks.
- ✓ Assume suitable data if necessary.

1. Discuss the advantages and limitations in solving mathematical problems by numerical techniques rather than analytically. [4]
2. Find a negative real root of the following equation correct to three decimals using Bisection Method. [6]

$$\frac{1 - (x+1)^4}{x} - 1 = 0$$

3. What are limitations of Newton-Raphson method? Using Newton-Raphson method, find a root of the equation  $x \sin x - \cos x = 0$  correct to four decimal places. [2+4]
4. Solve the following system of linear equation, using Gauss-Elimination method with partial pivoting technique. [8]

$$\begin{aligned} x_1 - 3x_2 + 8x_3 &= 3 \\ 5x_1 + x_2 + 2x_3 &= 9 \\ x_1 + 7x_2 - x_3 &= 14 \end{aligned}$$

5. Obtain the dominant eigen value and its corresponding eigen vector of the following matrix using Power method. [8]
6. Using the Method of Least Squares, fit the following set of data to a curve of the form  $y = a \log_e x + b$ . [8]

x	0.5	1.0	1.5	2	2.5	3
y	3.7	5.3	5.8	6.6	6.9	7.5

7. Using the cubic spline technique, estimate  $f(4)$  from the following data: [8]

x	1	3	5	7	9
f(x)	1.5	-0.4	-6.9	6.1	6.4

8. Derive composite Simpson's 3/8 formula for integration. [4]
9. Use Romberg's method to compute  $\int_0^1 \frac{1}{1+x^2} dx$  correct to three decimal places. [6]
10. Using Euler's method, solve  $\frac{dy}{dx} = \frac{y+x}{y-x}$ , with  $y=1$  at  $x=0$ , for  $x=0.1$ ,  $h=0.02$ . [6]

11. Solve the following boundary value problem using Finite Difference Method taking a step-size of 0.5.  $y''+2y'+y=3x^2$  subject to boundary conditions  $y(0) = 5$  and  $y(2)=4$ . [8]
12. Solve the Laplace equation  $u_{xx} + u_{yy} = 0$  for the square mesh with boundary conditions as shown in the figure attached. [8]

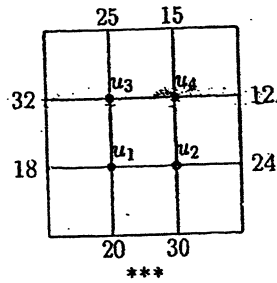

Exam.	Back		
Level	BE	Full Marks	80
Programme	BCE, BME, BAME, BIE	Pass Marks	32
Year / Part	III / I	Time	3 hrs.

**Subject: - Numerical Methods (SH603)**

- ✓ Candidates are required to give their answers in their own words as far as practicable.
- ✓ Attempt All questions.
- ✓ The figures in the margin indicate Full Marks.
- ✓ Assume suitable data if necessary.

1. Explain the importance of Numerical Methods in the field of Science and Engineering. [4]
2. Write a pseudo-code to find a real root of a non-linear equation using False Position method. [6]
3. Find a positive root of the equation  $x^2 \sin x - e^x + 2 = 0$  correct to 3 decimals using Bisection method. [6]
4. Using L-U method solve, the following system of equations [8]
 
$$\begin{aligned} 2x + 3y + z &= 1 \\ 6x - 3y + 4z &= 17 \\ 5x + 7y + 6z &= 10 \end{aligned}$$
5. Determine the dominant eigen value and corresponding vector of the following matrix using the power method: [8]
 
$$\begin{bmatrix} 2 & 6 & 3 \\ 6 & 5 & 4 \\ 3 & 4 & 9 \end{bmatrix}$$
6. Fit the following set of data to a curve of the form  $y = ae^{bx}$ . [8]
 

x	2	3	4	5	6	7
y	15.1	10.2	7.8	5.5	3.8	1.7
7. Using the Cubic Spline interpolation technique, estimate the value of  $y(4)$  from the following data: [8]
 

x	1	3	5	7
y	1.56	-0.43	-16.90	6.10
8. Derive an expression to evaluate first derivative from Newton's backward interpolation formula and evaluate  $\frac{dy}{dx}$  at  $x = 8$  from the following table. [3+3]
 

x	0	2	4	6	8
y	0	-0.7553	-11.2151	34.2867	-8.3226

9. Use Simpson's  $\frac{1}{3}$ -rule to evaluate  $\int_0^6 \frac{2x^2 + 5}{1+x} dx$ , taking  $n = 6$  and also find the absolute error with exact value. [3+1]
10. Write a pseudo-code to solve an initial value problem of first order differential equation using Runge-Kutta 2 method. [4]
11. Using Fourth-order Runge Kutta method, solve the following differential equation for  $y$  at  $x = 0.2$  and  $r = 0.4$ ;  
 $y'' - xy'^2 + y^2 = 0$ ,  $y(0) = 1$ ,  $y'(0) = 0$  [8]
12. Solve Poisson's equation  $U_{xx} + U_{yy} = 243(x^3 + y^3)$  over the square domain  $0 \leq x \leq 1$ ,  $0 \leq y \leq 1$  with step size  $h = \frac{1}{3}$  with  $u = 100$  on the boundary. [10]

\*\*\*

Exam.	Regular		
Level	BE	Full Marks	80
Programme	BCE, BME, BAME, BIE	Pass Marks	32
Year / Part	III / I	Time	3 hrs.

**Subject: - Numerical Methods (SH603)**

- ✓ Candidates are required to give their answers in their own words as far as practicable.
- ✓ Attempt All questions.
- ✓ The figures in the margin indicate Full Marks.
- ✓ Assume suitable data if necessary.

1. Define error and write its different types with examples. If  $x = 1.350253$  is rounded off to Four significant digits, find absolute and relative errors. [4]
2. Write an algorithm to find a real root of a non linear equation using secant method. [6]
3. What are limitations of Newton-Raphson method? Using Newton-Raphson method, find a root of equation  $x \sin x + \cos x = 0$  which is near to  $x = \pi$ . [2+4]
4. Solve the following system of linear equation using Gauss-Seidal method, correct to 3 decimal places. [8]

$$\begin{aligned} 2x_1 + 6x_3 - 3x_4 &= 31 \\ 6x_1 + 2x_4 &= 14 \\ -3x_1 + 5x_2 &= 9 \\ 2x_1 + x_2 - 5x_3 + 9x_4 &= -9 \end{aligned}$$

5. Obtain the dominant eigen value and its corresponding eigen vector of following matrix using Power Method. [8]

$$\begin{bmatrix} 1 & 4 & 4 \\ 4 & 1 & 8 \\ 4 & 8 & 1 \end{bmatrix}$$

6. Fit the curve of the form  $y = a \log_e x + b$  to the following data sets. [8]

x	2	3	4	5	6	7
y	5.45	6.26	6.84	7.29	7.66	7.96

7. Approximate  $y(2)$  and  $y(10)$  using appropriate interpolation formula from the following data: [8]

x	3	4	5	6	7	8	9
y	4.8	8.4	14.5	23.6	36.2	52.8	73.9

8. Derive Newton-Cotes general quadrature formula for integration and use it to obtain Simpson's  $\frac{1}{3}$  rule of integration. [6]

9. Evaluate  $\int_0^1 \frac{\tan^{-1} x}{x}$  using Gaussian 3 point formula. [4]

10. Solve the following boundary value problem using shooting method [10]

$$\frac{d^2 y}{dx^2} - 2 \frac{dy}{dx} + y = e^x, \text{ with } y(1) = 1 \text{ and } y(2) = 5; \text{ Taking } h = 0.25$$

11. Write a pseudo-code to solve an initial value problem of first order using Runge - Kutta 4 method. [4]

12. Derive recurrence formula for solving one dimensional heat equation  $U_t = c^2 U_{xx}$ . Using it solve the heat equation  $U_t = 0.5 U_{xx}$ ,  $0 \leq x \leq 5$ ,  $0 \leq t \leq 4$  with boundary conditions  $U(x, 0) = xe^x (5 - x)$ ,  $U(0, t) = 0$  and  $U(5, t) = 0$ ; taking  $h = 1$ . [4+4]

Exam.	Back		
Level	BE	Full Marks	80
Programme	BCE, BME, BIE	Pass Marks	32
Year / Part	III / I	Time	3 hrs.

**Subject: - Numerical Methods (SH603)**

- ✓ Candidates are required to give their answers in their own words as far as practicable.
- ✓ Attempt All questions.
- ✓ The figures in the margin indicate Full Marks.
- ✓ Assume suitable data if necessary.

1. Discuss the significance of Numerical Methods in the field of science and engineering. [4]
2. Find a real root of the equation  $\cos x - xe^x = 0$ , correct to four decimal places, using Regula-falsi method. [6]
3. Write pseudo-code for finding a real root of a non-linear equation using the Secant Method. [6]
4. Solve the following system of linear equations using the Gauss-Elimination Method. [8]

$$3x_1 - 2x_2 + 3x_3 + 2x_4 = 16$$

$$2x_1 - 3x_2 + 2x_3 + 3x_4 = 9$$

$$5x_1 + 3x_2 - 5x_3 + 4x_4 = 7$$

$$4x_1 + 2x_2 + 2x_3 - 3x_4 = 16$$

5. Find the dominant Eigen value and corresponding vector of the following matrix using the Power Method. [8]

$$\begin{bmatrix} 5 & 2 & 3 \\ 2 & 4 & 2 \\ 3 & 2 & 5 \end{bmatrix}$$

6. Write the pseudocode to fit a given set of data to a second degree polynomial ( $y = a + bx + cx^2$ ) using the Least Square Method. [8]
7. Fit the following data to the curve  $y = ax^b$  using least square method. [8]

x	350	400	500	600
y	61	26	7	2.6

8. Evaluate  $\int_0^2 (\sin x + \cos x) dx$  using Gaussian 3-point formula. [6]
  9. Derive the formula for computing first and second derivative using Newton's forward difference interpolation formula. [6]
  10. Solve the following boundary value problem using Shooting Method employing Euler's formula taking a step-size of 0.25. [10]
- $y'' = x - y + y'$  subject to boundary conditions  $y(0) = 2$  and  $y(1) = 3$
11. Solve the elliptic equation (Laplace)  $\mu_{xx} + \mu_{yy} = 0$  for the square mesh  $0 \leq x \leq 1, 0 \leq y \leq 1$  where  $h = \Delta x = 0.25$  and  $k = \Delta y = 0.25$  with the following boundary conditions: [10]

$$\begin{array}{l} u(0, 0) = 0 \\ u(0, 0.25) = 1000 \\ u(0, 0.50) = 2000 \\ u(0, 0.75) = 1000 \\ u(0, 1) = 0 \end{array} \left| \begin{array}{l} u(0.25, 0) = 500 \\ u(0.25, 1) = 500 \end{array} \right| \left| \begin{array}{l} u(0.5, 0) = 1000 \\ u(0.5, 1) = 1000 \end{array} \right| \left| \begin{array}{l} u(0.75, 0) = 500 \\ u(0.75, 1) = 500 \end{array} \right| \left| \begin{array}{l} u(1, 0) = 0 \\ u(1, 0.25) = 1000 \\ u(1, 0.50) = 2000 \\ u(1, 0.75) = 1000 \\ u(1, 1) = 0 \end{array} \right.$$

Exam.	Regular		
Level	BE	Full Marks	80
Programme	BCE, BME, BIE	Pass Marks	32
Year / Part	III / I	Time	3 hrs.

**Subject: - Numerical Methods (SH603)**

- ✓ Candidates are required to give their answers in their own words as far as practicable.
- ✓ Attempt **All** questions.
- ✓ The figures in the margin indicate **Full Marks**.
- ✓ Assume suitable data if necessary.

1. What are the applications of Numerical methods in the field of science and engineering? Discuss briefly. [4]
2. Find a real root of  $e^x - \cos x = 3$  correct to three places of decimal using the Bisection method. [6]
3. What are the drawbacks of Newton-Raphson method? Discuss. [6]
4. Solve the following system of linear equations using LU factorization method. [8]
 
$$\begin{aligned} x_1 + 2x_2 - x_3 &= 2 \\ x_1 - 3x_2 + 2x_3 &= 1 \\ 2x_1 + 4x_2 + 3x_3 &= 19 \end{aligned}$$
5. Apply power method to find the largest eigen value of the following matrix. [8]
 
$$\begin{bmatrix} 4 & -1 & 1 \\ -1 & 3 & -2 \\ 1 & -2 & 3 \end{bmatrix}$$
6. Write the pseudo-code to fit a polynomial to a given set of data by Lagrange's interpolation method. [8]
7. Estimate  $y(3)$  from the following data using cubic spline interpolation technique. [8]
 

x	2	4	6	8	10
y	2	3	6	3	2
8. Derive Newton-cotes quadrature formula for integration. [4]
9. Evaluate  $\int_{-1}^2 e^{-x^2} dx$  using 3-point Gaussion Quadrature formula. [6]
10. Solve  $y' = 2x + \sin y$  for  $y(0.2)$  subject to the condition  $y(0) = 1$  using Modified Euler's method. [4]
11. Solve the following boundary value problem using finite difference method by dividing the interval into four sub intervals. [8]
 
$$y'' + 3y' - y = \cos x, \quad y(0) = 2 \quad \text{and} \quad y(2) = 3$$
12. Solve Poisson's equation  $u_{xx} + u_{yy} = 729x^2y^2$  on a square grid with  $0 \leq x \leq 1, 0 \leq y \leq 1$  with  $u = 0$  on the boundary. Take step size  $h = \frac{1}{3}$  [10]





Exam.	New Back (2066 & Later Batch)		
Level	BE	Full Marks	80
Programme	BCE, BME, BIE	Pass Marks	32
Year / Part	III / I	Time	3 hrs.

**Subject:** - Numerical Methods (SH603)

- ✓ Candidates are required to give their answers in their own words as far as practicable.
- ✓ Attempt All questions.
- ✓ The figures in the margin indicate Full Marks.
- ✓ Assume suitable data if necessary.

1. Construct Divided Difference table from the following data: [4]

x	1	2	4	5	6
y	14	15	5	6	19

2. Find an approximation of the root of the equation  $x^3 - x - 11 = 0$  by using Bisection method correct to three decimal places. [6]

3. Write an algorithm for finding a real root of non-linear equation using Newton Raphson method. [6]

4. Solve the following system of linear equations using Gauss-Seidal iteration method. [8]

$$6x_1 + x_2 - x_3 + 2x_4 = 4$$

$$2x_1 + 5x_2 - 4x_3 + 6x_4 = -5$$

$$x_1 + 4x_2 + 3x_3 - x_4 = 2$$

$$x_1 + x_2 + 2x_3 + x_4 = 5$$

5. Find the largest Eigenvalue and corresponding Eigenvector of the following matrix using power method. [8]

$$\begin{bmatrix} 2 & -1 & 0 \\ -1 & 2 & -1 \\ 0 & -1 & 2 \end{bmatrix}$$

6. Evaluate  $y(10)$  by using Lagrange's interpolation formula from the following data: [8]

x	5	6	9	11
y	12	13	14	16

7. Using least square method, fit a curve  $y = ae^{bx}$  to the following data: [8]

x	4	5.5	7	8	10
y	18.47	39.11	82.79	136.5	371.03

8. Find the value of  $\cos(1.74)$  from the following table. [4]

x	1.7	1.74	1.78	1.82	1.86
sinx	0.9916	0.9857	0.9781	0.9691	0.9584

9. Derive composite simpson's three-eight formula for the integration. [6]

10. Write Pseudocode to solve a first order differential equation using R-K 4 method. [6]

11. Solve the boundary value problem  $y'' + xy' + y = 3x^2 + 2, y(0) = 0, y(1) = 1$  [6]

12. Solve the laplace equation  $U_{xx} + U_{yy} = 0$  over the square grid with boundary condition as shown in figure. [10]

	80	100	80	
50	U1	U2	U3	50
60	U4	U5	U6	60
50	U7	U8	U9	50
	80	100	80	

Exam.	Regular		
Level	BE	Full Marks	80
Programme	BCE, BME, BIE	Pass Marks	32
Year / Part	III / I	Time	3 hrs.

**Subject: - Numerical Methods (SH603)**

- ✓ Candidates are required to give their answers in their own words as far as practicable.
- ✓ Attempt All questions.
- ✓ The figures in the margin indicate Full Marks.
- ✓ Assume suitable data if necessary.

1. Write an algorithm to solve a non-linear equation using secant method. [6]
2. Find the positive root of equation  $\cos x - 1.3x = 0$ , correct to six decimal places using Newton Raphson Method. [6]
3. Discuss the limitations of fixed point iteration methods graphically. [4]
4. Using Factorisation method, solve the given system of linear equations. [8]

$$\begin{aligned} 2x - 5y + z &= 12 \\ -x + 3y - z &= -8 \\ 3x - 4y + 2z &= 16 \end{aligned}$$

5. Find the largest eigen value and corresponding eigen vector of the matrix: [8]

$$\begin{bmatrix} 1 & 3 & -1 \\ 3 & 2 & 4 \\ -1 & 4 & 10 \end{bmatrix}$$

6. using least square method, fit a curve  $y = ax^2 + bx + c$  to the following data: [8]

x	20	40	60	80	100	120
y	5.5	9.1	14.9	22.8	33.3	46.0

7. Use cubic spline interpolation to estimate  $f(2.5)$  from given table. [8]

x	1	2	3	4
f(x)	0.5	0.3333	0.25	0.20

8. Derive Newton-cotes quadrature formula for integration and use it to obtain the trapezoidal rule of integration. [6]

9. The following table gives distance (s) of a particle at time (t): [4]

t	0.2	0.4	0.6	0.8	1.0	1.2
s	0.12	0.49	1.12	2.02	3.20	4.67

Calculate the velocity at time  $t = 0.3$

10. Write Pseudocode to solve a first order differential equation using Euler's method. [4]
11. Using Fourth order Runge-Kutta method, solve the following differential equation for y at  $x = 0.2$  and  $x = 0.4$ : [8]

$$y'' - xy'^2 + y^2 = 0, y(0) = 1, y'(0) = 0$$

12. Solve Poisson's equation  $u_{xx} + u_{yy} = 729x^2y^2$  over the square domain  $0 \leq x \leq 1, 0 \leq y \leq 1$  with step size  $h = 1/3$  with  $u = 0$  on the boundary. [10]

Exam.	New Back (2066 & Later Batch)		
Level	BE	Full Marks	80
Programme	BCE, BME, BIE	Pass Marks	32
Year / Part	III / I	Time	3 hrs.

**Subject: - Numerical Methods (SH603)**

- ✓ Candidates are required to give their answers in their own words as far as practicable.
- ✓ Attempt All questions.
- ✓ The figures in the margin indicate Full Marks.
- ✓ Assume suitable data if necessary.

1. Show that the following data pairs satisfy a cubic polynomial by constructing a divided difference table. [4]

x	1	2	4	5	7	8
y	8.8	5.5	3.7	4.0	4.0	2.5

2. Find a positive real root of the equation  $xe^x + \sin x = 0.5$  with an accuracy of 6 decimal places using Newton-Raphson Method. [6]
3. Write pseudo-code to find a real root of a given non-linear equation using Secant Method. [6]
4. Solve the following system of linear equations using Factorization Method. [8]
- $$9x_1 + 5x_2 - 8x_3 = 19$$
- $$5x_1 - 3x_2 + 8x_3 = 19$$
- $$7x_1 + 4x_2 - 5x_3 = 19$$

**OR**

Write a high-level language (C/C++/FORTRAN) program to compute the inverse of a non-singular square matrix using Gauss Jordan Method.

5. Find the largest Eigen value and corresponding vector of the following matrix using Power Method. [8]

$$\begin{bmatrix} 1.4 & 1.3 & 2.2 \\ 1.3 & 3.5 & 1.5 \\ 2.2 & 1.5 & 3.2 \end{bmatrix}$$

6. Fit the following set of data to a curve of the form  $y = a \log_e x + b$  [8]

x	2	4	6	8	10	12	14
y	4.7	7.2	8.3	9.6	10.4	10.7	10.9

7. Evaluate  $y(1.6)$ ,  $y(7.8)$  and  $y(4.2)$  from the following data using appropriate polynomial interpolation technique used for equally spaced intervals. [8]

x	1	2	3	4	5	6	7	8
y	2.3	1.8	2.0	3.0	4.4	5.0	3.9	1.7

8. Derive formula for first derivative using Newton forward interpolation formula. [5]

9. Evaluate  $\int_0^{\pi} x \sin x dx$  using 3-point Gauss Legendre formula. [5]

10. Solve  $y' = \sin x + \cos y$ ,  $y(0) = \pi$  in the range  $0 \leq x \leq 2$  by dividing the interval into 5 sub-intervals using Euler's method. [4]

11. Apply Runge-Kutta method of fourth order to find  $y(0.5)$  and  $y(1)$  from following equation  $\frac{dy}{dx} = \frac{y^2 + x^2}{x + y}$  with  $y(0) = 1$ . [8]

12. Solve the Poisson's equation  $\nabla^2 u = x^3 + y^3$  over the square region  $0 \leq x \leq 3$  and  $0 \leq y \leq 3$  subject to  $u(x,0) = 0$ ,  $u(0,y) = 0$ ,  $u(3,0) = 0$  and  $u(0,3) = 0$  taking  $\Delta x = \Delta y = 1$ . [10]

01/06

05 TRIBHUVAN UNIVERSITY  
INSTITUTE OF ENGINEERING  
**Examination Control Division**  
2071 Chaitra

Exam.	Regular		
Level	BE	Full Marks	80
Programme	BCE, BME, BIE	Pass Marks	32
Year / Part	III / I	Time	3 hrs.

**Subject:** - Numerical Methods (SH603)

- ✓ Candidates are required to give their answers in their own words as far as practicable.
- ✓ Attempt All questions.
- ✓ The figures in the margin indicate Full Marks.
- ✓ Assume suitable data if necessary.

1. Calculate a real root of  $x^7 + \sin x - \cos x = 0$  accurate up to 3 decimal places using Bisection Method. [6]
2. Write pseudo-code to find a real root of a given non linear equation using False Position Method. [6]
3. Discuss the limitations of Newton-Raphson Method in finding a real-root of a non-linear equation. [4]
4. Use Gauss Jordan method to find the inverse of following matrix A. [8]

$$A = \begin{bmatrix} 1 & 1 & 3 \\ 1 & 3 & -3 \\ -2 & -4 & -4 \end{bmatrix}$$

5. Compute the dominant Eigen value of the following matrix using Power Method. [8]

$$\begin{bmatrix} 3 & 4 & 5 \\ 4 & 3 & 6 \\ 5 & 6 & 5 \end{bmatrix}$$

6. From the following table estimate  $f(1.6)$  using Newton's forward interpolation method. [8]

x	1	1.4	1.8	2.2
f(x)	3.49	4.82	5.96	6.5

7. Estimate  $y(5)$  from the following data using Cubic Spline Interpolation technique. [8]

x	2	4	6	8
y	4	5	7	6

OR

Write a high-level language (C/C++/FORTRAN) program to complete Lagrange's interpolation.

8. Find approximate values of  $y'(3)$  and  $y''(3)$  from the following function: [4]

x	2	2.5	3	3.5	4
y	5.53	5.74	4.62	2.96	2.89

9. Evaluate  $\int_0^1 \frac{\tan^{-1} x}{x} dx$  using Romberg method correct up to 3 decimal places. [6]

10. Solve  $y'' + 3y' - y = 2x$  subject to the boundary conditions  $y(0) = 3$  and  $y(2) = 4$  in the range  $0 \leq x \leq 2$  by dividing the interval into four sub-intervals using the finite difference method. [8]

11. Write pseudo-code to solve an initial value problem (first order ordinary differential equation) using the Runge- Kutta fourth order method. [4]

12. Solve the equation  $\nabla^2 u = -10(x^2 + y^2 + 10)$  over the square with sides  $x = 0 = y$ ,  $x = 3 = y$  with  $u = 0$  on the boundary and mesh length = 1 [10]

\*\*\*

Exam.	New Back (2066 & Later Batch)		
Level	BE	Full Marks	80
Programme	BCE, BME, BIE	Pass Marks	32
Year / Part	III / I	Time	3 hrs.

**Subject: - Numerical Methods (SH603)**

- ✓ Candidates are required to give their answers in their own words as far as practicable.
- ✓ Attempt All questions.
- ✓ The figures in the margin indicate Full Marks.
- ✓ Assume suitable data if necessary.

1. Find a real root of the following equation, correct to four decimals, using the False Position method. [6]

$$x^3 - 5x - \sin(x) - 6 = 0$$

2. Derive analytically the iteration formula for Newton-Raphson method to find a real root of a non-linear equation. [4]
3. Write an algorithm to find a real root of a non-linear equation using the Bisection Method. [6]
4. Solve the following system of linear equations using the Gauss-Seidal Iteration Method. [8]

$$\begin{aligned} 9x_1 + 2x_2 - 3x_3 &= 10 \\ 5x_1 + 11x_3 + 2x_4 &= 30 \\ x_2 + 3x_3 + 7x_4 &= 25 \\ 2x_1 + 8x_2 - 2x_4 &= 15 \end{aligned}$$

OR

Write pseudo-code for solving a system of linear equations using the Gauss Elimination Method.

5. Find the dominant Eigen value and corresponding vector of the following matrix using the Power method. [8]

$$\begin{bmatrix} 1 & 4 & 3 \\ 4 & 2 & 7 \\ 2 & 6 & 5 \end{bmatrix}$$

6. Evaluate  $f(2.5)$  from the following data using Newton's Divided difference interpolation formula: [8]

$x$	1	2	3	4	5	6
$f(x)$	8.9	9.2	16.3	35.6	72.5	132.4

7. Fit the following data to an exponential curve of the form  $y = ab^x$ . [8]

$x$	2	4	6	8	10
$y$	2	6	25	115	300

8. Find  $y'(0.2)$  and  $y''(0.2)$  from the following data: [5]

$x$	0.1	0.2	0.3	0.4	0.5
$y$	2.6	8.2	15.4	25.6	37.8

9. Evaluate the following using Gaussian three point formula: [5]

$$\int_0^2 x \sin(\cos x) + 2 dx$$

10. Solve the following initial value problem using the Modified Euler's method for  $0 \leq x \leq 0.6$  with an interval of 0.2 [6]

$$\frac{dy}{dx} = \sin x + \cos y; \quad y(0) = 3$$

11. Explain the technique of solving a two-point boundary value problem using the shooting method. [6]

12. Solve  $u_{xx} + u_{yy} = 0$  for the following square mesh with boundary conditions as shown in the figure. [10]

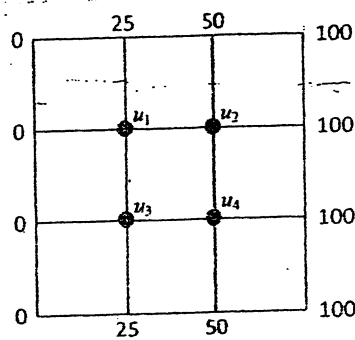

\*\*\*

05 TRIBHUVAN UNIVERSITY  
 INSTITUTE OF ENGINEERING  
**Examination Control Division**  
 2070 Chaitra

Exam.	Regular		
Level	BE	Full Marks	80
Programme	BCE,BME,BIE	Pass Marks	32
Year / Part	III / I	Time	3 hrs.

**Subject: - Numerical Methods (SH603)**

- ✓ Candidates are required to give their answers in their own words as far as practicable.
- ✓ Attempt All questions.
- ✓ The figures in the margin indicate Full Marks.
- ✓ Assume suitable data if necessary.

1. How do we obtain a real root of a non-linear equation using Secant method? Explain graphically and hence deduce the iteration formula. [4]
2. Write an algorithm to find a real root of a non-linear equation using Bisection method. [4]
3. Find a positive real root of  $\sin(x) + \cos(x) + e^x - 8 = 0$  correct up to 4 decimal places using Newton-Raphson method. [6]
4. Solve the following system of equations using the LU Factorization method. [8]

$$\begin{aligned} 4x + 3y + z &= 33 \\ 2x + 5y + 3z &= 41 \\ 2x + y + 5z &= 47 \end{aligned}$$
5. Obtain the numerically dominant Eigen value and corresponding eigen vector of the following matrix, using power method. [8]

$$\begin{bmatrix} 1 & 3 & -1 \\ 3 & 2 & 4 \\ -1 & 4 & 10 \end{bmatrix}$$
6. From the following data, find the cubic polynomial between  $x = 3$  and  $x = 4$  using the natural cubic Spline interpolation technique. [8]

x	2	3	4	5	6
y	5	6	4	3	2

OR

Write a program in C to numerically interpolate a value from a given data set using Lagrange's interpolation formula.

7. Fit the following set of data to a curve of the form  $y = a e^{bx}$  [8]

x	1	2	3	4	5	6	7	8
y	2	3	4	5	7	10	15	30

8. A slider in a machine moves along a fixed straight rod. Its displacement  $x$  cm. along the rod is given below at different instant of time  $t$  seconds. Find the velocity of the slider and its acceleration when  $t = 0.2$  seconds. [4]

t	0.0	0.1	0.2	0.3	0.4
x	30.13	31.62	32.87	33.64	33.95

9. Evaluate the following integral correct to three decimals using Romberg's method. [6]

$$\int_2^4 \left( 4 + \frac{\cos(X)}{e^{\sin x}} \right) dx$$

10. Using the finite difference approximation, solve the following boundary value problem for three interior points. [8]

$$y'' + 4y' - 3y = \sin(x); \text{ with boundary conditions } y(2) = 3 \text{ and } y(4) = 4$$

11. Write pseudo-code to solve an initial value problem (first order ordinary differential equation) using the Runge-Kutta fourth order method. [6]

12. Solve the Poisson's partial differential equation  $u_{xx} + y_{yy} = -10(x^2 + y^2 + 10)$  over the region  $0 \leq x \leq 3$  and  $0 \leq y \leq 3$  with boundary conditions:  $u(0, y) = 0, u(3, y) = 0, u(x, 0) = 0$  and  $u(x, 3) = 0$  Assume mesh length = 1 [10]

\*\*\*



06 TRIBHUVAN UNIVERSITY  
INSTITUTE OF ENGINEERING  
Examination Control Division  
2070 Chaitra

Exam.	Old Back (2065 & Earlier Batch)		
Level	BE	Full Marks	80
Programme	All (except B. Arch)	Pass Marks	32
Year / Part	III / I	Time	3 hrs.

**Subject: - Numerical Methods (EG601SH)**

- ✓ Candidates are required to give their answers in their own words as far as practicable.
- ✓ Attempt any **Five** questions. **Question No. 6 is compulsory.**
- ✓ The figures in the margin indicate **Full Marks**.
- ✓ Assume suitable data if necessary.

1. Use the Bisection method to find a real root having accuracy within  $10^{-2}$  for  $x^3 - 7x^2 + 14x - 6 = 0$  on the interval  $[0, 1]$ . [8]
- b) Let  $f(x) = -x^3 - \cos x$ , find a real root using secant method with accuracy 0.01. [8]
2. a) Construct the interpolating polynomial of degree four for the unequally spaced points given in the following table: [8]

x	0.0	0.1	0.3	0.6	1.0
f(x)	-6.000000	-5.89483	-5.65014	-5.17788	-4.28172

Find the value for  $x = 2.5$  using polynomial.

- b) Estimate coefficient of  $Y = ax + b$  for following data using least square method. [8]

x	4	5	6	7	8	9
y	14	12	11	9	6	4

3. a) A car laps a race track in 84 s. The speed of the car at each 6-s interval is determined using a radar gun and is given from the beginning of the lap, in feet/second, by the entries in the following table. [8]

Time	0	6	12	18	24	30	36	42	48	54	60	66	72	78	84
Speed	124	134	148	156	147	133	121	109	99	85	78	89	104	116	123

Calculate the acceleration at  $t = 12S$  and  $t = 54S$ .

- b) Approximate the following integrals using Gaussian quadrature with  $n=2$  and compare your results to the values of the integrals  $\int_0^1 x^2 e^{-x} dx$ . [8]
4. a) Solve the following linear algebraic equation using Gauss-Jordan method: [8]

$$X_1 + 3X_3 + 2X_4 = 17$$

$$3X_2 + 3X_3 + 2X_4 = 18$$

$$-2X_1 + 2X_2 + X_3 = 20$$

- b) Solve the following equations using Jacobi's Iteration method. [8]

$$3x + 4y + 15z = 54.8; \quad x + 12y + 3z = 39.66; \quad 10x + y - 2z = 7.74$$

5. a) What is initial value problem and boundary value problem? Explain with example. [4]

- b) Using Runge-Kutta method of order 4<sup>th</sup>, solve  $y'' = y + xy'$ , given that  $y(0) = 1, y'(0) = 0$ , find  $y(0.2)$  and  $y'(0.2)$  with step size  $h = 0.1$ .

6. Write an algorithm, flow chart and Pseudo code to solve system of equation by Gauss-Jordan method. Program should be capable to solve 2 to 10 system of equations. [16]

Exam.	BE	Full Marks	80
Level	BE	Pass Marks	32
Programme	BCE, BME, BIE	Time	3 hrs.
Year / Part	III / I		

**Subject: - Numerical Methods (SH603)**

- ✓ Candidates are required to give their answers in their own words as far as practicable.
- ✓ Attempt All questions.
- ✓ The figures in the margin indicate Full Marks.
- ✓ Assume suitable data if necessary.

1. What is error? Explain absolute, relative and percentage error, with example. [4]
2. Write an algorithm to find a real root of a non linear equation using ~~secant~~ method. [6]
3. Find the cube root of 30, correct to 3 decimal places using Newton-Raphson method. [6]
4. Solve the following system of linear equations using factorization method. [8]

$$\begin{aligned} 4x_1 + 4x_2 + 5x_3 &= 31 \\ 2x_1 + 6x_2 + 2x_3 &= 23 \\ 3x_1 + 2x_2 + 2x_3 &= 15 \end{aligned}$$

OR

Write pseudo-code for solving a system of linear algebraic equations using the Gauss-Jordan Method.

5. Determine the dominant Eigen value and corresponding vector of the following matrix using the power method. [8]

$$\begin{bmatrix} 2 & 6 & 3 \\ 6 & 5 & 4 \\ 3 & 4 & 9 \end{bmatrix}$$

6. Develop pseudocode to interpolate the given sets of data using Lagrange interpolation method. [6]
7. Using the cubic spline interpolation technique, find the cubic polynomial between  $x = 2$  and  $x = 3$  from the following data and also evaluate  $y(2.5)$ : [10]

x	0	1	2	3	4
y	2	-6	-8	2	4

8. The distance  $y$  covered in time  $t$  by an object moving in a straight line is given below; approximate the velocity at  $t = 1$  second and acceleration at  $t = 5$  seconds. [4]

t(in seconds)	0	1	2	3	4	5
y(in meters)	0	15	71	143	245	367

9. Compute  $\int_1^2 \frac{dx}{x}$  using Romberg method correct upto 3 decimal places. [6]
10. Solve the equation  $y'' = x+y$  with the boundary conditions  $y(0) = y(1) = 0$ , using finite difference method, taking four sub intervals. [10]

11. Derive Schmidt recurrence formula to solve one dimensional heat equation  $\frac{\partial u}{\partial t} = c^2 \frac{\partial^2 u}{\partial x^2}$  [4]

12. Solve the Poisson's equation  $\nabla^2 u = 8x^2 y^2$  for the square mesh  $0 \leq x \leq 3$ ,  $0 \leq y \leq 3$  with  $u = 0$  on the boundary and mesh length = 1. [8]

Exam.	Regular		
Level	BE	Full Marks	80
Programme	BCE, BME, BIE	Pass Marks	32
Year / Part	III / 1	Time	3 hrs.

**Subject: - Numerical Methods (SH603)**

- ✓ Candidates are required to give their answers in their own words as far as practicable.
- ✓ Attempt All questions.
- ✓ The figures in the margin indicate Full Marks.
- ✓ Assume suitable data if necessary.

1. Using the divided different table, show that the following data satisfies a cubic polynomial. [4]

x	1	3	4	5	7	9
y	2.9	2.3	14.6	41.5	166.7	418.1

2. Write an algorithm to find a real root of a non-linear equation using Bisection Method. [6]
3. Find a real root of the following equation correct to three decimals using the Secant method.  $e^{\cos x} = \sin x$  [6]
4. Solve the following system of linear equations using Gauss-Seidel's method [8]

$$\begin{aligned} -x_1 - x_2 - 2x_3 + 10x_4 &= -9 \\ 10x_1 - 2x_2 - x_3 - x_4 &= 3 \\ -2x_1 + 10x_2 - x_3 - x_4 &= 15 \\ -x_1 - x_2 + 10x_3 - 2x_4 &= 27 \end{aligned}$$

$$2x_3 - x_4 = 8$$

Your answer must be correct to three decimal places.

OR

Write pseudo-code to solve a system of linear equations of 'N' unknowns using the Gauss-elimination method.

5. Obtain the numerically dominant Eigen value and corresponding eigenvector of the

following matrix using Power Method. [8]

$$\begin{bmatrix} 15 & -4 & -3 \\ 10 & 12 & -6 \\ -20 & 4 & -2 \end{bmatrix}$$

6. Using the Cubic Spline interpolation technique, estimate the value of  $y(9)$  from the following data: [8]

x	4	6	8	10
y	2	5	8	6

7. Fit the following set of data to a curve of the form  $y = a e^{bx}$ . [8]

x	2	3	4	5	6	7
y	15.1	10.2	7.8	5.5	3.8	1.7

8. A rod is rotating in a plane. The following table gives the angle  $\theta$  (radians) through which the rod is turned for various values of the time  $t$  second: [4]

t	0.0	0.2	0.4	0.6	0.8	1.0	1.2
$\theta$	0	0.12	0.49	1.12	2.02	3.20	4.67

Calculate the angular velocity and the angular acceleration of the rod, when  $t = 0.2$  and  $1.0$  second.

9. Derive Simpson's 1/3 rule for integration. Evaluate the following integral using Simpson's

1/3 rule, taking  $h = 0.25$   $\int_0^1 \frac{e^x}{x+1} dx$  [4+2]

10. Solve the following boundary value problem using the finite difference method by dividing the interval into four sub-intervals.  $\frac{d^2y}{dx^2} = \sin x + y$ ;  $y(0) = 3$ ;  $y(1) = 4$  [8]

11. Write pseudo-code to solve an initial value problem (first order ordinary differential equation) using Euler's method. [4]

12. Solve the Poisson's equation  $u_{xx} + u_{yy} = -81xy$ ,  $0 < x < 1$ ,  $0 < y < 1$  with boundary condition:  $u(0,y) = u(x,0) = 0$  and  $u(1,y) = u(x,1) = 100$ ; taking  $h = 1/3$ . [10]

\*\*\*

65 TRIBHUVAN UNIVERSITY  
 INSTITUTE OF ENGINEERING  
 Examination Control Division  
 2068 Chaitra

Exam.	B.E. (Civil)		
Level	BE	Full Marks	80
Programme	BCE, EME, BIE	Pass Marks	32
Year / Part	III / I	Time	3 hrs.

**Subject: - Numerical Methods (SH 603)**

- ✓ Candidates are required to give their answers in their own words as far as practicable.
- ✓ Attempt All questions.
- ✓ The figures in the margin indicate Full Marks.
- ✓ Assume suitable data if necessary.

1. Generate the forward difference table from the following data:

x	0	1	2	3	4	5	6
f(x)	0	2.2	4.7	8.5	14.3	20.7	30.1

2. Derive iterative formula for Newton-Raphson method using Taylor-series. [4]
3. Find a root of the equation  $x^3 - 4x - 9 = 0$ , using bisection method, correct upto three decimal places. [4]
4. Solve the following system of linear equations using the factorization method. [8]

$$\begin{aligned} 2x + 2y + 3z &= 17 \\ 3x + 2y + z &= 12 \\ 5x + 2y + 2z &= 18 \end{aligned}$$

OR

Write the Pseudo-code for solving a system of linear equations using the Gauss Jordan Method.

5. Find the dominant Eigen value and corresponding Eigen vector of the following matrix using the Power method. [8]

1	-2	3
-2	4	2
3	2	9

6. Using Lagrange interpolation formula, find the value of  $f(1.3)$  from following data [8]

X	1	3	4
Y	4.28	2.18	4.13

7. Estimate the co-efficients of  $y = ax + b$  for the following data using least square method. [8]

X	-2.0	-1.0	0.5	2.0	3.0	5.5
Y	-0.4	1.2	3.5	6.0	7.4	11.0

8. Derive the expression for evaluating derivative by forward difference method. [4]

9. Evaluate  $\int_0^6 \frac{dx}{1+x^2}$  using Simpson's 1/3 rule taking unit interval size. [6]

10. Solve  $\frac{dy}{dx} = y - \frac{3x}{y}$ ,  $y(0) = 1.5$  in the range  $0 \leq x \leq 0.4$  taking  $h = 0.2$  using Modified Euler's method, performing iteration for an accuracy of four decimal places in each step. [10]

11. Solve the elliptic equation  $u_{xx} + u_{yy} = 0$  for the following square mesh with boundary conditions as exhibited in the figure below. [12]

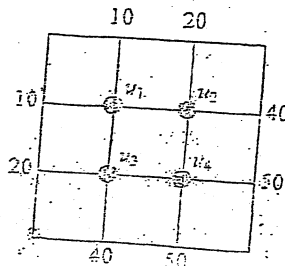



Exam.	Regular / Back		
Level	BE	Full Marks	80
Programme	All (Except B.Arch.)	Pass Marks	32
Year / Part	III / I	Time	3 hrs.

**Subject: - Numerical Methods**

- ✓ Candidates are required to give their answers in their own words as far as practicable.
- ✓ Attempt any Five questions. Question No. 6 is compulsory.
- ✓ The figures in the margin indicate Full Marks.
- ✓ Assume suitable data if necessary.

1. a) Find the root of the equation  $e^x - 3x = 0$  correct upto three decimal places using bisection method. [8]

b) Find the reciprocal of 3 using Newton Raphson method. [8]

2. a) Apply Newton's forward difference formula to find  $y(3.5)$  from the following data. [8]

x	1	2	3	4	5	6	7	8
y	1	8	27	64	125	216	343	512

b) Obtain a relation of the form  $y = ae^{bx}$  for the following data by the method of least squares. [8]

x:	0.0	0.5	1.0	1.5	2.0	2.5
y:	0.10	0.45	2.15	9.15	40.35	180.75

3. a) Use Romberg integration method to evaluate the integral  $\int_1^2 \frac{dx}{x}$  correct upto 3 decimal places taking the initial sub interval size as  $h = (b - a)/2$ . [10]

b) The velocity V of a particle at a distance S from a point on its path is given in the table below: [6]

S (ft)	0	10	20	30	40	50	60
V (ft/sec)	47	58	64	65	61	52	38

Estimate the time taken to travel a distance of 60ft by using Simpson's 1/3 rule. Compare the result with Simpson's 3/8 rule.

4. a) Find the largest eigen value correct to three significant digits and corresponding eigen vector of the following matrix using power method. [8]

$$A = \begin{bmatrix} 1 & 2 & 3 \\ 2 & -1 & 4 \\ 3 & 4 & 5 \end{bmatrix}$$

b) Use Gauss Jordan method to find the inverse of the following matrix. [8]

$$A = \begin{bmatrix} 2 & 2 & 1 \\ 1 & 3 & 1 \\ 1 & 2 & 2 \end{bmatrix}$$

5. a) Solve  $y' = xy + y^2$ ,  $y(0) = 1$  for  $y(0.1)$  and  $y(0.2)$  using Runge-Kutta method of fourth order. [8]

b) Consider a metal plate of size  $30\text{cm} \times 30\text{cm}$ , the boundaries of which are held at  $100^\circ\text{C}$ . Calculate the temperature at interior points of the plate. Assume the grid size of  $10\text{cm} \times 10\text{cm}$ . [8]

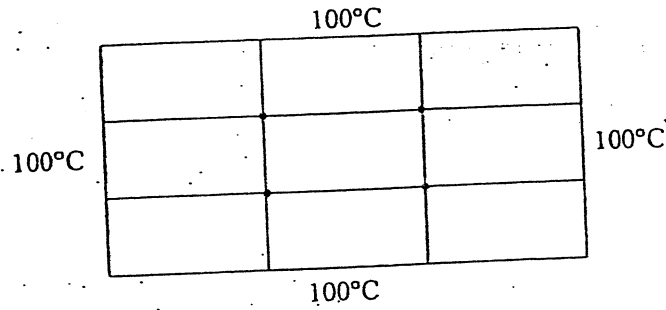

6. Write algorithm, flowchart and program code in any one of the high level languages (FORTRAN or C) to fit the parabola  $y = a + bx + cx^2$  where  $a$ ,  $b$  and  $c$  are constants, Hence find the value of  $y$  when  $x$  is an user defined value. [16]

\*\*\*



Exam.	Regular		
Level	BE	Full Marks	80
Programme	BCE	Pass Marks	32
Year / Part	III / I	Time	3 hrs.

**Subject: - Theory of Structures II (CE 601)**

- ✓ Candidates are required to give their answers in their own words as far as practicable.
- ✓ Attempt All questions.
- ✓ The figures in the margin indicate Full Marks.
- ✓ Assume suitable data if necessary.

1. a) Describe the degree of static and kinematic indeterminacies with examples. [6]
- b) Using Castigliano's theorem determine the deflection at point B for a propped cantilever beam. EI is constant throughout the member. [10]

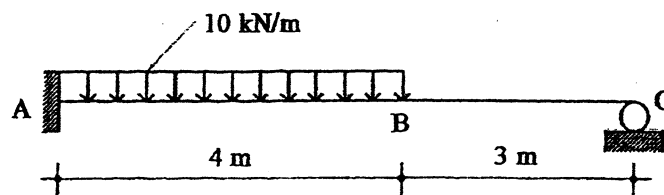

2. a) Determine reactions at hinged support using force method. [10]

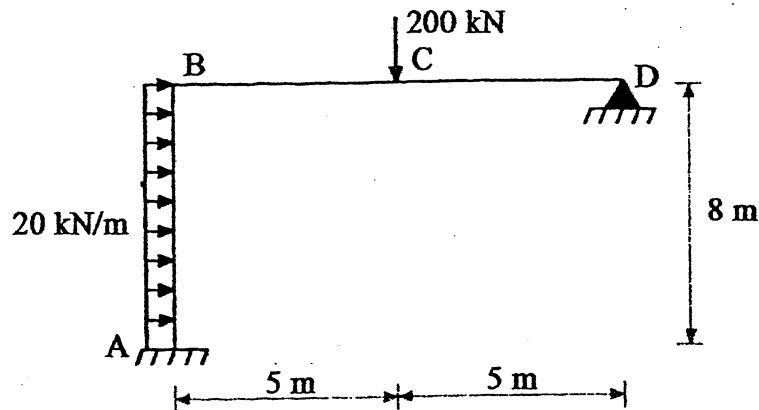

- b) Calculate the reactions of the two hinged arch. If there is a temperature rise by  $10^\circ\text{C}$  what will be the change in reactions. Assume  $I_x = I_0 \sec \phi$  and  $\alpha = 10^{-5}/^\circ\text{C}$ . [10]

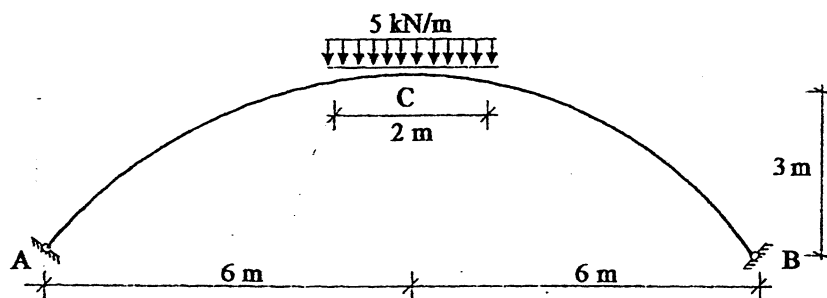

3. a) Analyze the one bay one story frame shown in figure below using either Stiffness Matrix Method. [12]

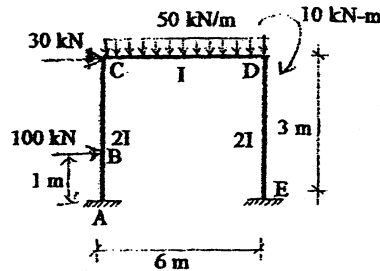

- b) What is the moment distribution method? Define carry-over moment and distribution factor. [4]

4. a) Generate stiffness matrix of the given truss and use it to find its member forces. [7]

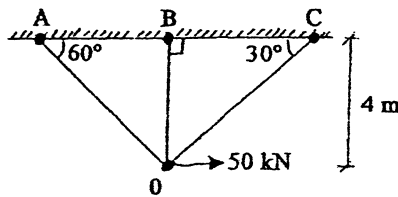

- b) Analyse the given propped cantilever beam by using the three-moment equation. [6]

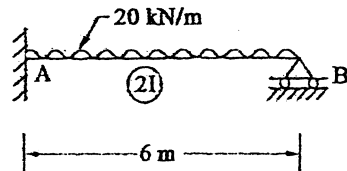

5. a) Draw influence line diagram for moment at fixed support. Find ordinates at 4 m interval. [5]

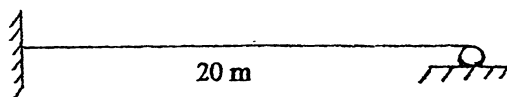

- b) Define plastic hinge, plastic moment capacity and shape factor. [4]

- c) Determine shape factor for the composite shown in figure below. [6]

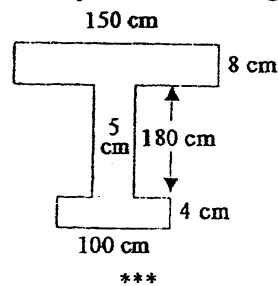

Exam.	Back		
Level	BE	Full Marks	80
Programme	BCE	Pass Marks	32
Year / Part	III / I	Time	3 hrs.

*Subject: - Theory of Structures II (CE 601)*

- ✓ Candidates are required to give their answers in their own words as far as practicable.
- ✓ Attempt All questions.
- ✓ The figures in the margin indicate Full Marks.
- ✓ Assume suitable data if necessary.

1. a) Explain the physical significance of flexibility and stiffness matrices with suitable examples. [4]
- b) In the beam ABC, support 'B' settles by  $\lambda Re$  units. Find reaction  $R_c$  using castigliano's theorem. [6]

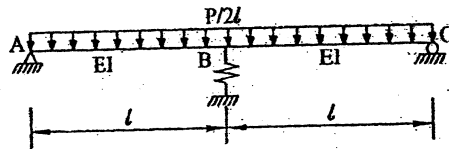

- c) Determine reactions at A, using Force method. [6]

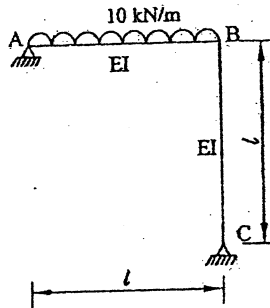

2. a) Find the BM at point D for the given two hinged parabolic arch. Take  $I_x = I_c \sec \theta$ . [10]

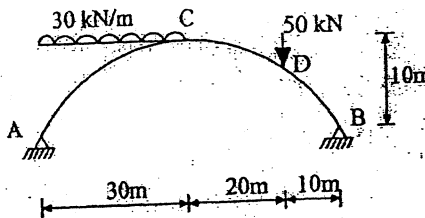

- b) Use consistent deformation method to draw the BM diagram of the given frame. [10]

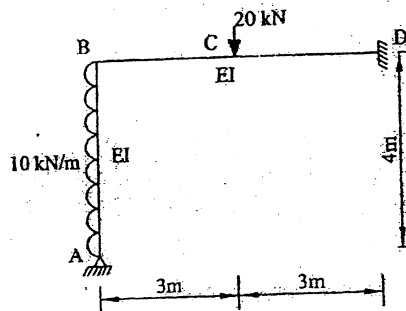

3. Analysis the given frame using stiffness matrix method.

[12]

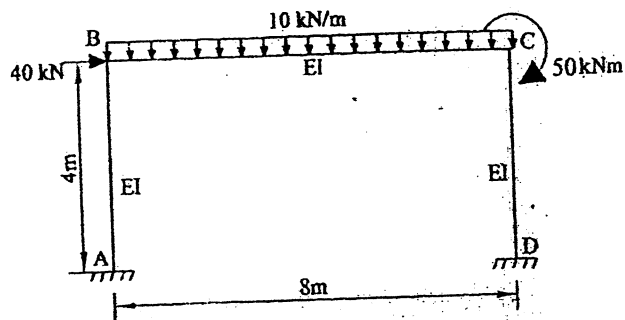

4. a) Draw the BMD for the given beam using slope deflection method.

[12]

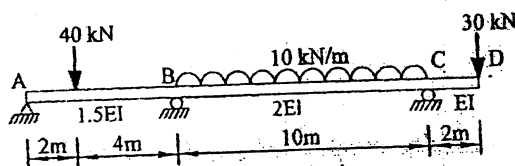

b) Explain the principle of moment distribution with example.

[4]

5. a) Draw ILD for the shear at section 1-1 of the propped cantilever beam given in figure,

[6]

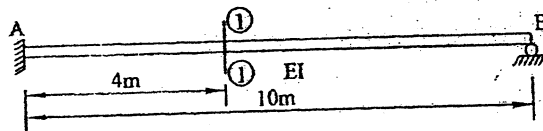

b) Evaluate the collapse load for the given frame.

[10]

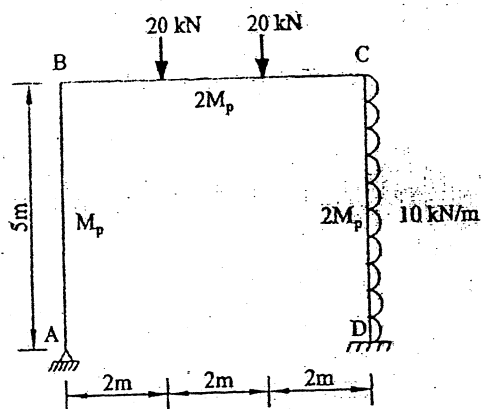

\*\*\*

Exam.	Regular		
Level	BE	Full Marks	80
Programme	BCE	Pass Marks	32
Year / Part	III / I	Time	3 hrs.

**Subject: - Theory of Structures II (CE 601)**

- ✓ Candidates are required to give their answers in their own words as far as practicable.
- ✓ Attempt All questions.
- ✓ The figures in the margin indicate Full Marks.
- ✓ Assume suitable data if necessary.

1. a) Determine degrees of static and kinematic indeterminacies of the frame shown in figure below. [4]

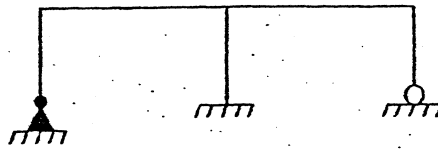

- b) State and prove castigliano's second theorem. [6]

- c) Analyze the given loaded beam using castigliano's theorem. The redundant should be considered as support moment at A. EI constant. [6]

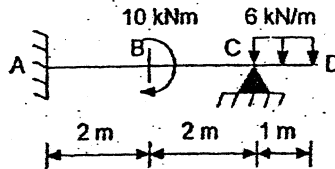

2. a) Analyse the portal frame ABCD shown in figure below using flexibility matrix method. Take  $EI = 12000 \text{ kN/m}^2$  [10]

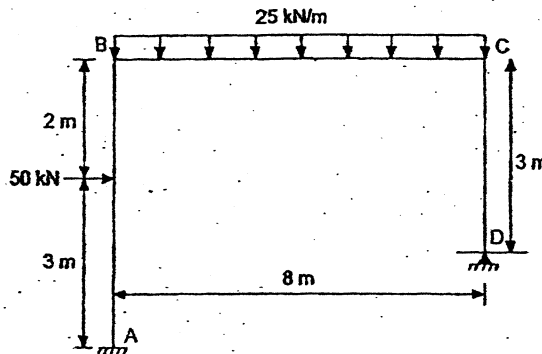

- b) Compute the bar force in the member AB, and EF due to the decrease in temperature of  $20^\circ\text{C}$  in all vertical members only. Take  $\alpha = 12 \times 10^{-6} / ^\circ\text{C}$  and  $E = 2 \times 10^5 \text{ N/mm}^2$  cross-sectional area of all members are  $35 \text{ cm}^2$ . [6]

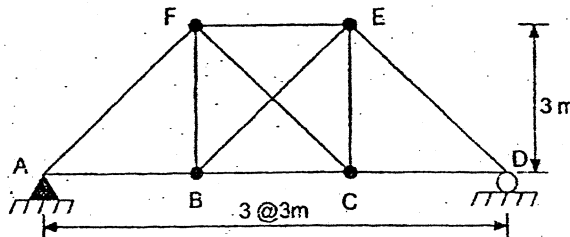

3. a) Draw shear force and bending moment diagram of the continuous beam using three moment equation method. [10]

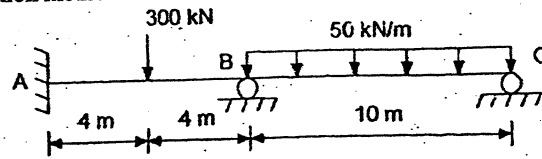

- b) Use Moment distribution method to analyze the frame loaded as shown below. Also draw BMD. [10]

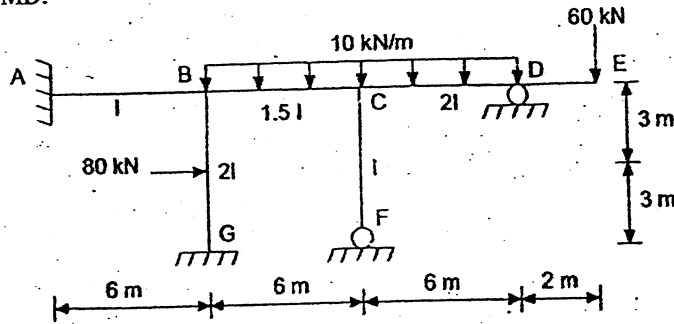

4. Analyse the frame given below using stiffness matrix method. [12]

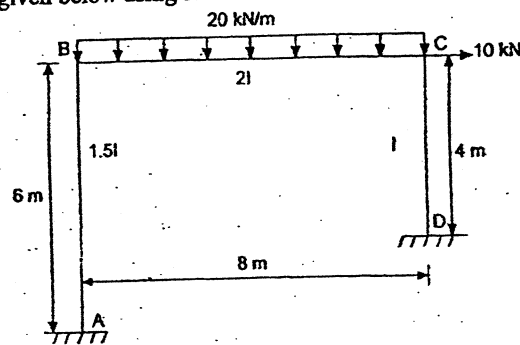

5. a) Draw influence line diagram for bending moment at point D. find values at interval 2.5 m in span AB and at 5 m interval on span BC. [6]

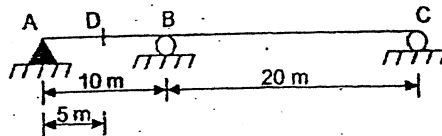

- b) Find the collapse load of the following frame. [10]

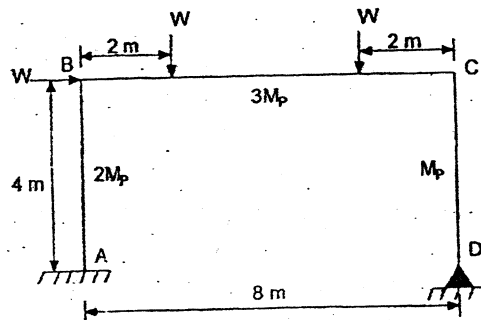

\*\*\*

Exam.	Back		
Level	BE	Full Marks	80
Programme	BCE	Pass Marks	32
Year / Part	III / I	Time	3 hrs.

**Subject: - Theory of Structure II (CE 601)**

- ✓ Candidates are required to give their answers in their own words as far as practicable.
- ✓ Attempt All questions.
- ✓ The figures in the margin indicate Full Marks.
- ✓ Assume suitable data if necessary.

1. a) Enunciate Betti's law and Maxwell's Reciprocal theorem and explain their uses. [6]
- b) Compute the bar forces in the members BG, HC, and CF of the following loaded truss structures as shown.  $AE = \text{constant}$ . [10]

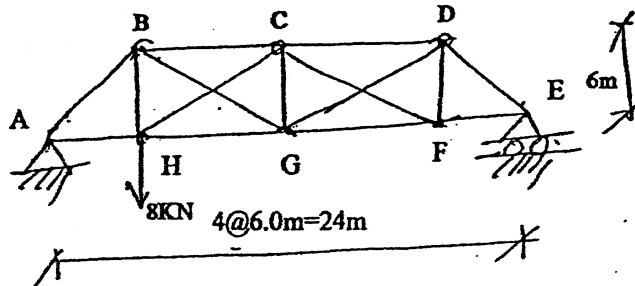

2. a) Determine end moments in a fixed beam of span  $L$  when one of the supports settles down by  $\Delta$  units. Take  $EI$  as the cross sectional stiffness of the beam. [6]
- b) Generate stiffness matrix of the structural system. [10]

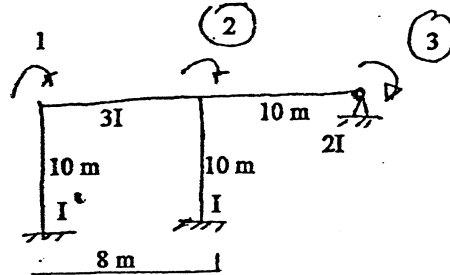

3. a) Derive slope deflection equations for a beam of span  $L$  and cross sectional stiffness  $EI$ . Assume other data, if required. [6]
- b) Determine moment at fixed support and rotation at roller support of a propped cantilever beam of span 10m and loaded with uniformly distributed load 30kN/m on its whole span and a point load of 50 kN at the centre using castigliano's theorem. [10]
4. a) Write down the compatibility equation for two hinged parabolic arch due to external loads, variation in temperature, Rib shortening and yielding of supports. [6]
- b) Draw BMD using slope deflection method. [10]

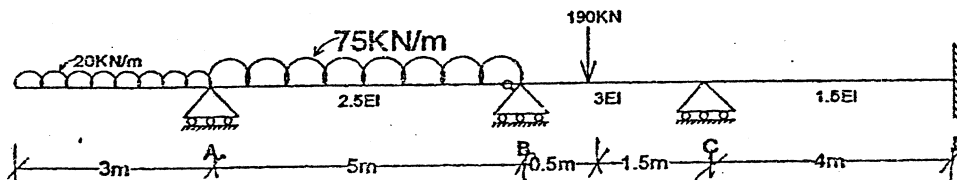

5. a) Draw Influence Line diagram for moment at support B of a propped cantilever beam as shown. Plot ordinates at 0.50 times span length. [6]

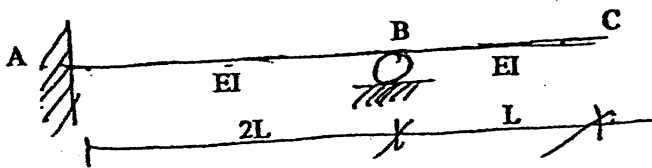

- b) Evaluate the collapse load for the given portal frame. Assume  $P=2ql$ . [10]

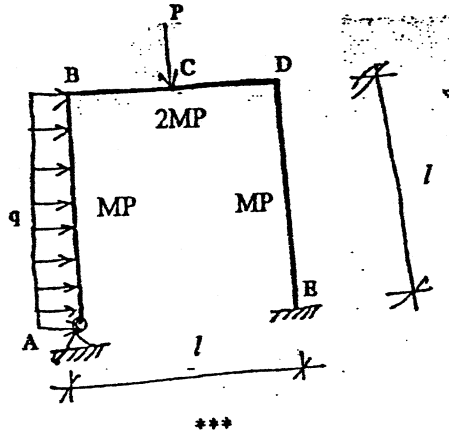



**TRIBHUVAN UNIVERSITY**  
**INSTITUTE OF ENGINEERING**  
**Examination Control Division**  
**2075 Chaitra**

Exam.	Regular / Back		
	Level	BE	Full Marks
Programme	BCE	Pass Marks	32
Year / Part	III / I	Time	3 hrs.

**Subject: - Theory of Structure II (CE-601)**

- ✓ Candidates are required to give their answers in their own words as far as practicable.
- ✓ Attempt All questions.
- ✓ The figures in the margin indicate Full Marks.
- ✓ Assume suitable data if necessary.

1. a) Define degree of static and kinematic indeterminacies and give suitable examples related to pin jointed, rigid jointed and hybrid structures to explain the concept. [6]
- b) Determine reactions at hinged support in the frame shown in figure below using force method. [10]

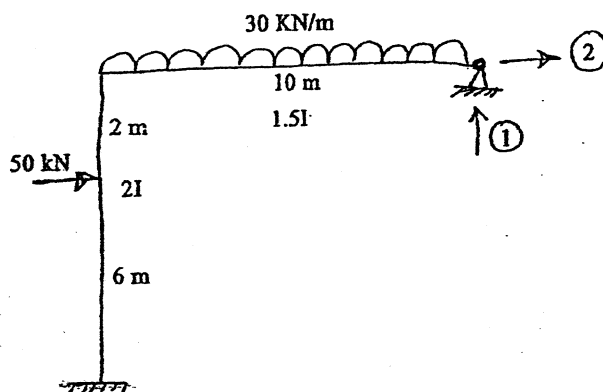

2. a) Determine end moments in a fixed beam of span L when left fixed support rotates clockwise by  $\theta_A$  radian. Take EI as constant. [6]
- b) Compute the final end moments for the following loaded frame using stiffness matrix method. [10]

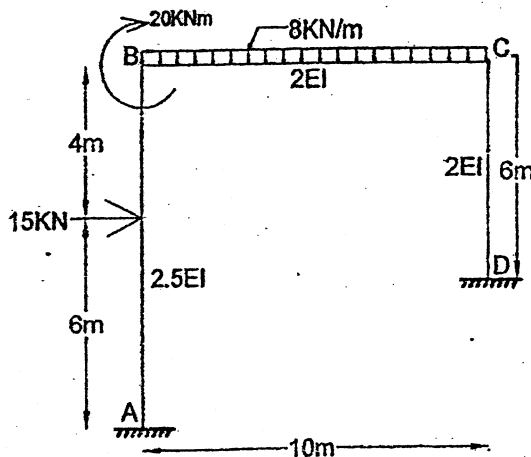

3. a) Explain with a neat sketch the concept of distribution and carry over factors in moment distribution method and give example. [6]

- b) Determine the support reaction at support 'C' using Castigliano's theorem.  $EI = \text{constant}$  throughout. [10]

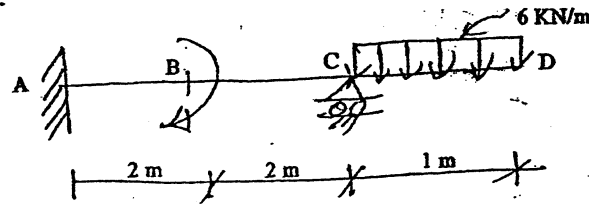

4. a) Find the bending moment at a given section x-x of the following loaded two hinged parabolic arch due to given loading. Take  $EI_c = 10000 \text{ kNm}^2$ . [6]

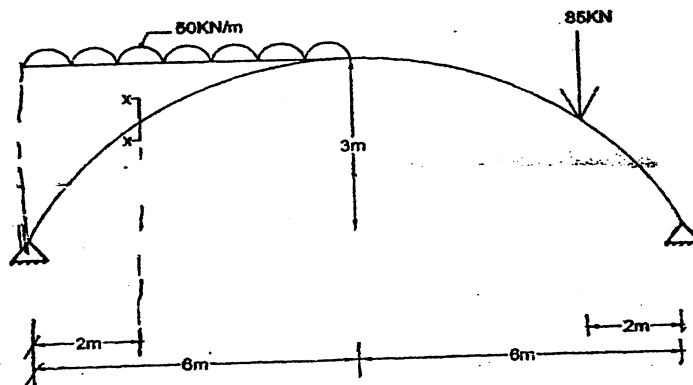

- b) Determine end moments and draw bending moment diagram by using slope deflection method. [10]

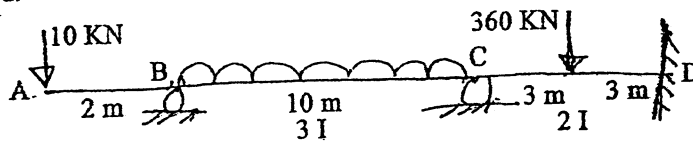

5. a) Draw ILD for the support moment at A by computing the ordinates at 3 meter intervals. [6]

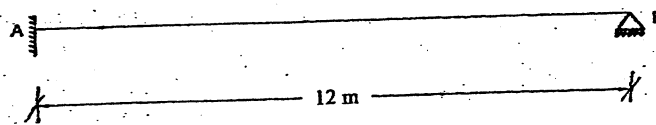

- b) Determine collapse load in the portal frame shown in figure below. [10]

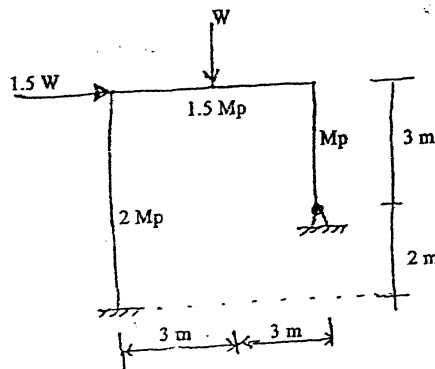

\*\*\*

Exam.	Regular		
Level	BE	Full Marks	80
Programme	BCE	Pass Marks	32
Year / Part	III / I	Time	3 hrs.

**Subject: - Theory of Structures II (CE 601)**

- ✓ Candidates are required to give their answers in their own words as far as practicable.
- ✓ Attempt All questions.
- ✓ The figures in the margin indicate Full Marks.
- ✓ Assume suitable data if necessary.

1. a) Explain theorems on displacement with suitable illustration. [4]  
 b) Find the reaction at support 'C' using Castigliano's theorem. [6]

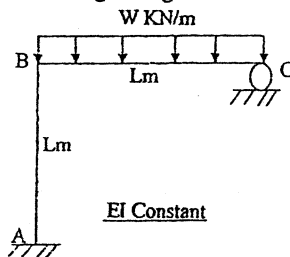

- c) In the given beam support 'B' is settled down by ' $\Delta$ ' units without rotation. Determine reactions at the supports. [6]

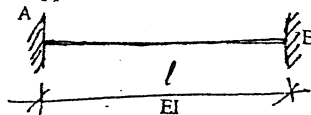

2. a) Determine reactions at hinged support using Force method when support D settles vertically downward by  $200/EI$ . Take EI to be constant. [10]

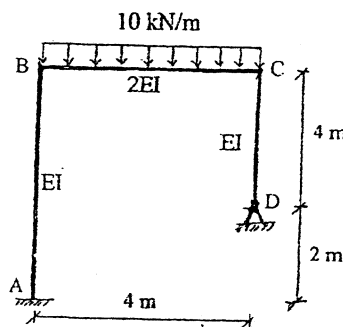

- b) Find the member forces of given loaded truss for given external loadings and due to rise in temperature of all diagonal members by  $20^\circ\text{C}$ . Take  $AE = 5000\text{KN}$  for all members and coefficient of thermal expansion as  $2.06 \times 10^{-6}/^\circ\text{C}$ . Additionally, vertical members are 5mm too long. [10]

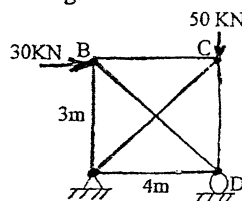

3. Draw BMD of the given frame using Stiffness matrix method.

[12]

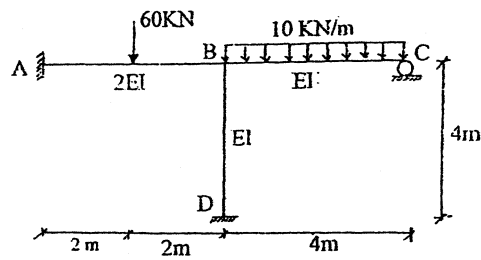

4. a) Derive expressions for Slope deflection equations for continuous beams.  
 b) Draw BMD of the given frame using moment distribution method.

[4]

[12]

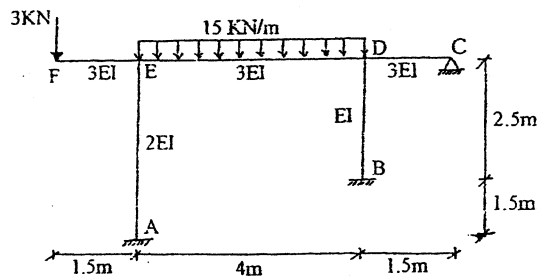

5. a) Draw ILD for reaction moment at fixed support of the propped cantilever beam of span 10m. Take ordinate interval as 2m.  
 b) Find the plastic moment capacity of the frame shown in figure below.

[6]

[10]

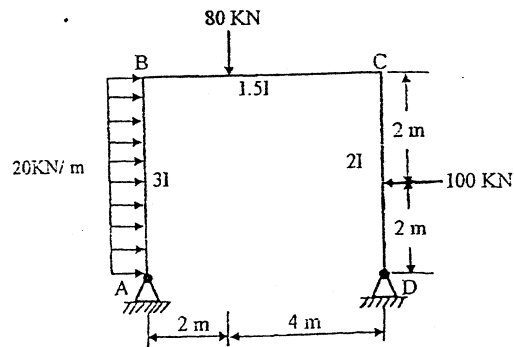

\*\*\*

Exam.	Back		
Level	BE	Full Marks	80
Programme	BCE	Pass Marks	32
Year / Part	III / I	Time	3 hrs.

**Subject: - Theory of Structures II (CE601)**

- ✓ Candidates are required to give their answers in their own words as far as practicable.
- ✓ Attempt All questions.
- ✓ The figures in the margin indicate Full Marks.
- ✓ Assume suitable data if necessary.

1. a) What is structural idealization? Explain the steps involve during identification and formulation of problems in theory of structure. [3+3]
- b) Determine the horizontal and vertical reaction at hinged support and also draw BMD using Force method. [10]

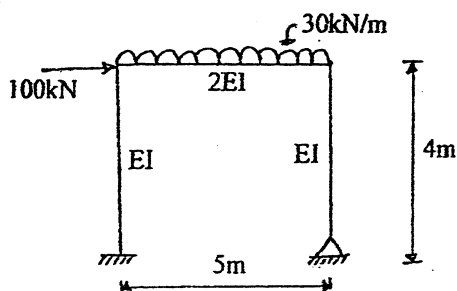

2. a) "Displacement method is unique in comparison to force method". Justify the statement giving suitable example. [4]
- b) Determine reaction at support B of the beam shown in figure below by castigliano's method. [6]

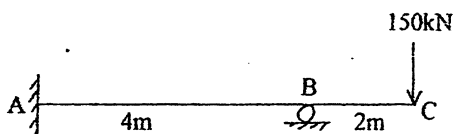

- c) A portal frame of span 6m and height 5m is hinged supported at both ends. The beam of the frame carries a uniformly distributed gravity load of intensity 50 kN/m. Use force method to solve the frame considering the flexural stiffness EI to be constant. Determine the reactions at both supports. [6]
3. a) Determine the forces in all members of the truss shown below, using force method. Take  $EA = 10^5 \text{kN}$ . [8]

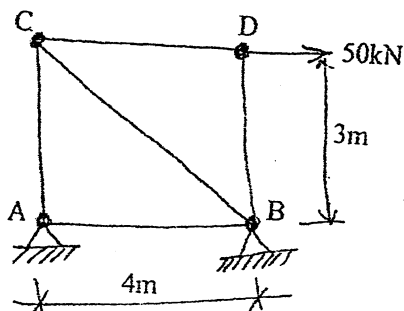

- b) Determine the collapse load  $W_c$  for the rectangular portal frame shown in figure below. [8]

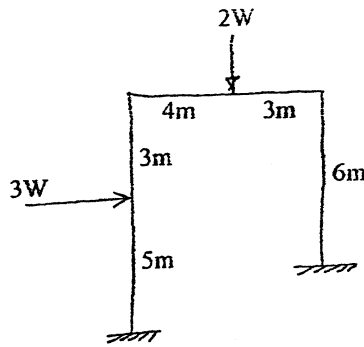

4. a) Draw ILD for S.F. at point C of the propped cantilever beam shown in figure below. [6]

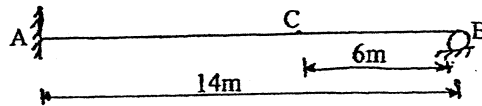

- b) Analyse the continuous beam loaded as shown in figure below using slope deflection method considering settlement of support C by 4mm downward. Take  $EI = 1 \times 10^9 \text{ t mm}^2$ . [10]

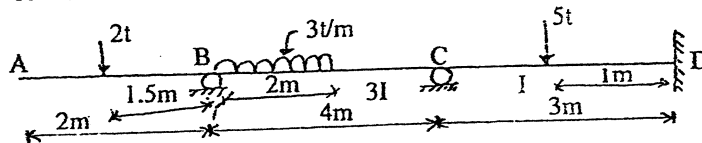

5. a) Generate stiffness matrix for the frame shown and determine the end reactions at the support. [8]

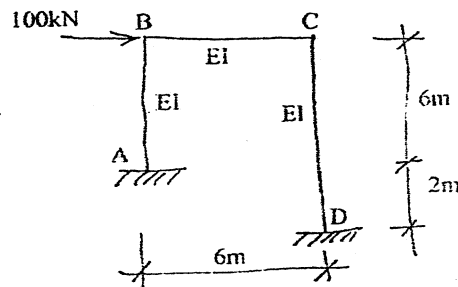

- b) Analyse the truss by displacement method. Take  $E = 2 \times 10^5 \text{ MPa}$ ,  $A = 8 \text{ cm}^2$  [8]

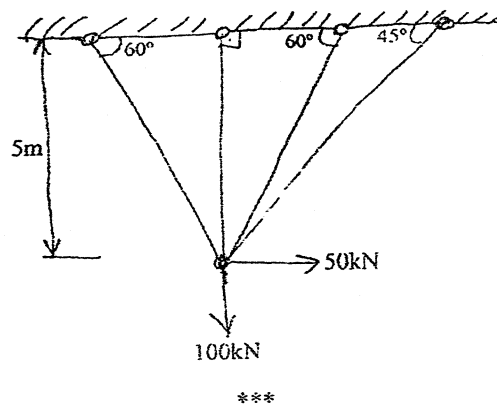

Exam.	Regular		
Level	BE	Full Marks	80
Programme	BCE	Pass Marks	32
Year / Part	III / I	Time	3 hrs.

**Subject: - Theory of Structures II (CE601)**

- ✓ Candidates are required to give their answers in their own words as far as practicable.
- ✓ Attempt **All** questions.
- ✓ The figures in the margin indicate **Full Marks**.
- ✓ Assume suitable data if necessary.

1. a) Define degree of static and kinematic indeterminacies. Give examples for each. [6]  
 b) Analyze the structure given below using Force method. Draw Shear force and Bending Moment diagrams. [10]

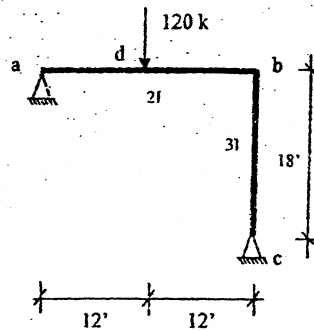

2. a) Derive the three moment equation and use it to solve single span fixed beam with uniform distributed load throughout the span. [6]  
 b) Generate stiffness matrix for the frame shown in below figure and determine the end moments and horizontal reactions at supports due to the load given. [10]

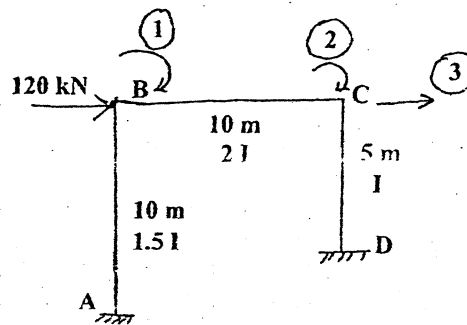

3. a) Determine forces in all members of the truss shown in figure below using force method. AE for all members is constant. [10]

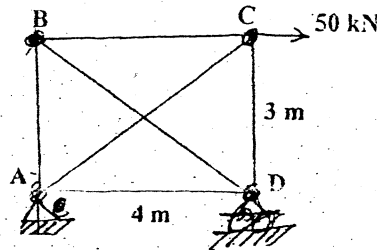

- b) Analyze the continuous beam shown in figure below by slope deflection method. Given  $I = 4 \times 10^7 \text{ mm}^4$ , and  $E = 200 \text{ kN/mm}^2$  Draw Bending Moment diagram. [8]

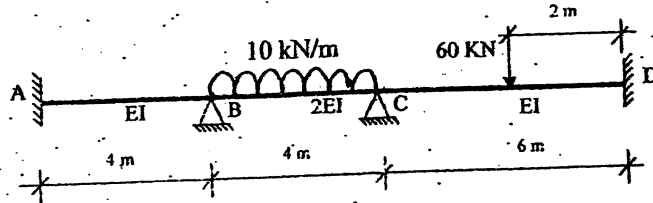

4. a) Explain with example how bending moment diagram is drawn for a statically indeterminate portal frame which undergoes settlement of one support. [4]  
 b) Analyze the truss shown in figure below by the stiffness matrix method and find the vertical and horizontal displacement at node A. [8]

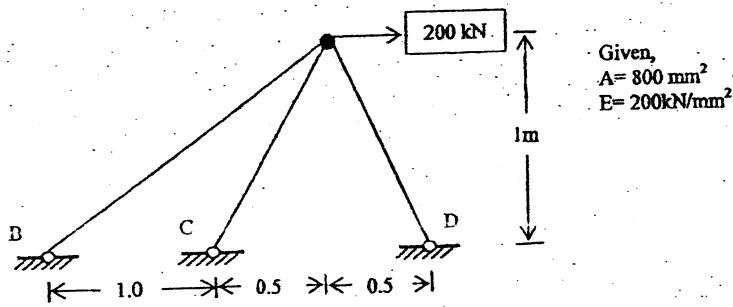

5. a) Draw the influence line for bending moment at Section 5 of a two span continuous beam as shown in figure below. Given ordinate at 2m interval. [10]

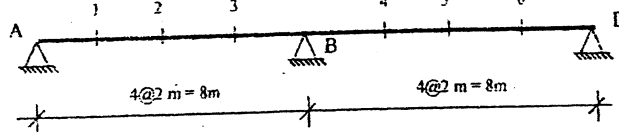

- b) Determine collapse load for the following beam. [4]

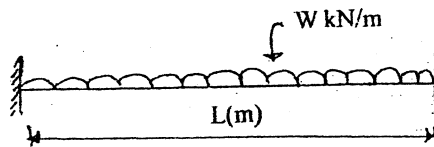

- c) Calculate the reaction at the prop of a propped cantilever with uniform distributed load throughout the span using Castigliano's theorem. [4]

\*\*\*



Exam.	Back		
Level	BE	Full Marks	80
Programme	BCE	Pass Marks	32
Year / Part	III / I	Time	3 hrs.

**Subject: - Theory of Structure II (CE601)**

- ✓ Candidates are required to give their answers in their own words as far as practicable.
- ✓ Attempt All questions.
- ✓ The figures in the margin indicate Full Marks.
- ✓ Assume suitable data if necessary.

1. a) Describe the degree of static indeterminacy and the degree of kinematic indeterminacy of a structural system with suitable expressions and examples. [5]
- b) Determine the moment at the fixed support of the following loaded beam using Castigliano's theorem. Take  $EI$  constant. [6]

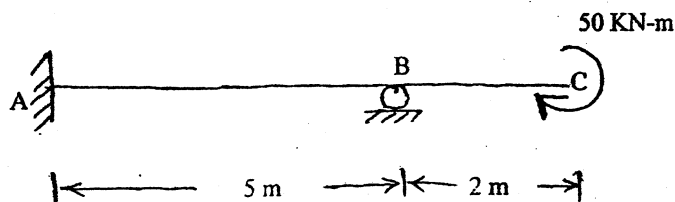

- c) Enunciate Mueller-Breslau principle of influence line and prove it with an example of a continuous beam. [5]
2. a) Explain the principle of moment distribution method with a simple example. [6]
- b) A portal frame of span 4 m and height 4 m is fixed at both supports. The beam of the frame carries a uniform distributed gravity load of intensity 30 kN/m. Use Force method to solve the frame considering the cross-sectional stiffness ( $EI$ ) to be constant. Draw bending moment, shear force and normal thrust diagrams for the frame. [10]
3. a) Analyse the continuous beam loaded as shown in figure below and draw the bending moment diagrams using slope-deflection method. Support B sinks by 19 mm. [12]

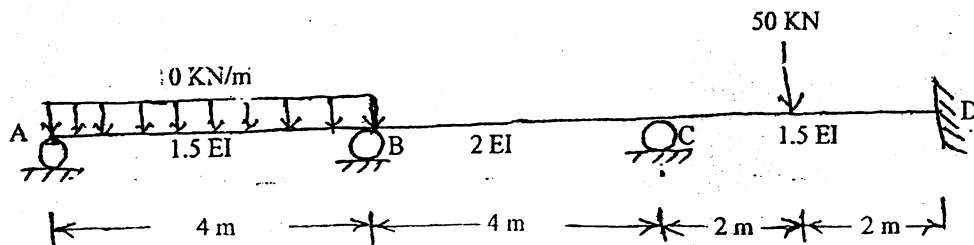

Take  $EI = 10,000 \text{ KN-m}^2$

- b) Define plastic hinge. Also compare plastic and elastic hinges of a structural system. [4]

4. a) Define the term left and right focal point ratios. Also write their expressions. [4]  
 b) Analyse the truss shown in figure below using "Force Method". Take the cross-sectional stiffness  $EA$  of the members to be constant. [12]

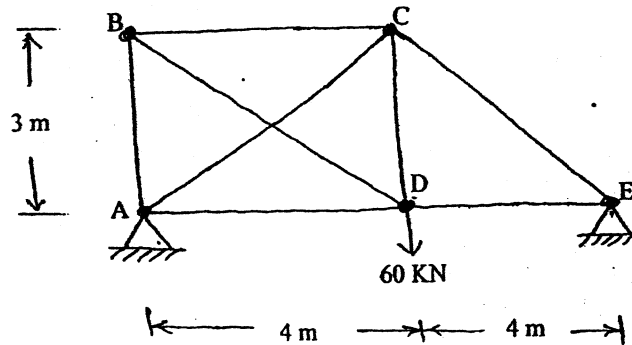

5. a) Generate stiffness matrix the frame loaded as shown in figure below. Also determine the end moments considering stiffness equations of each member. [10]

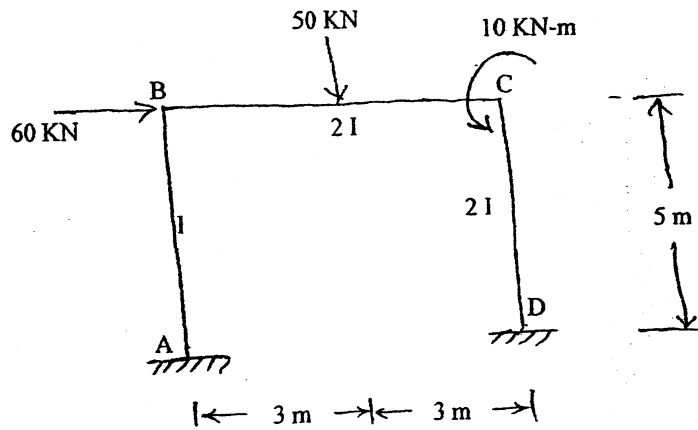

- b) Determine the collapse load,  $W_p$ , for the rectangular portal frame loaded as shown in figure below. [6]

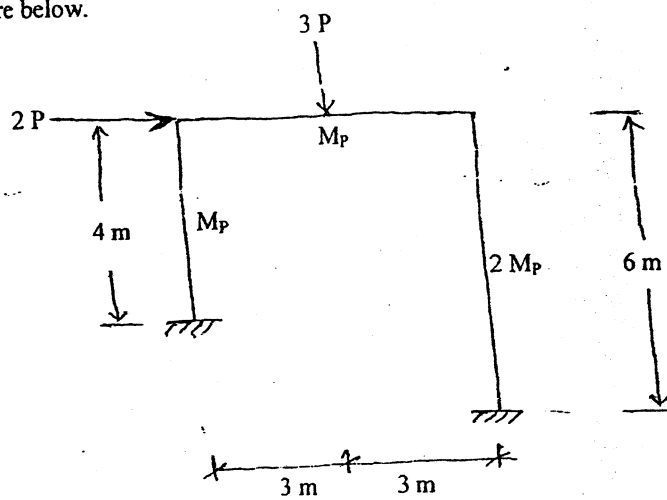

\*\*\*

Exam.	Regular		
Level	BE	Full Marks	80
Programme	BCE	Pass Marks	32
Year / Part	III / I	Time	3 hrs.

**Subject: - Theory of Structure II (CE601)**

- ✓ Candidates are required to give their answers in their own words as far as practicable.
- ✓ Attempt All questions.
- ✓ The figures in the margin indicate Full Marks.
- ✓ Assume suitable data if necessary.

1. a) Define static and kinetic indeterminacies of a structural system. Explain with an example for each of indeterminacy what they are used for. [6]
- b) Calculate the force in the members of the truss loaded shown in figure below using "Force Method". Take the cross-sectional stiffness EA of the members to be constant. [10]

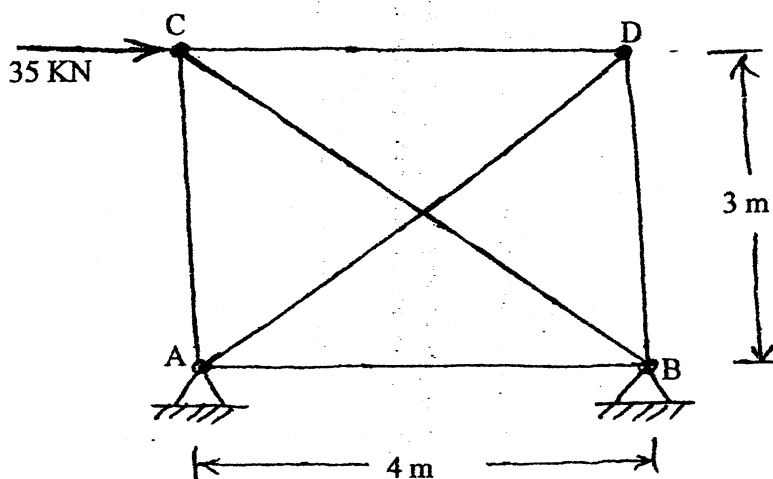

2. a) Derive moment expressions of slope-deflection method and explain whether the method used is force or displacement. Define with an example what is fixed end moment? [6]
- b) Analyse the beam shown in figure below by Moment Distribution Method. Also draw BMD indicating the salient points. Supports B sinks by 15 mm. [10]

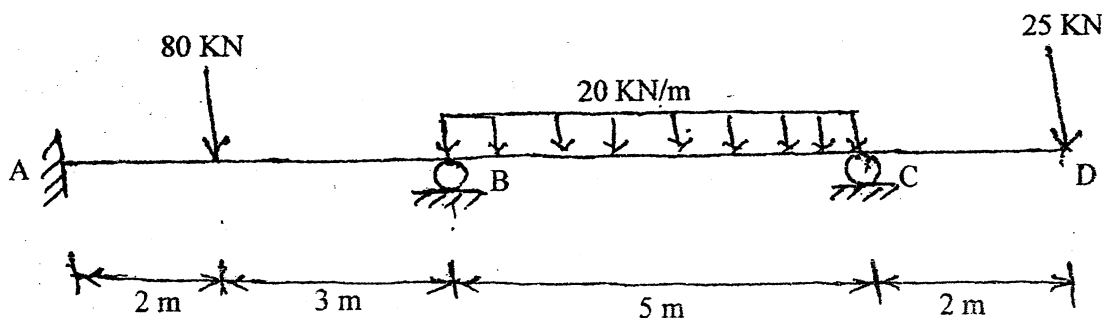

Take  $EI = 10000 \text{ KN-m}^2$ , and is constant throughout.

3. a) Differentiate between stiffness and flexibility. Also explain their relationships. [4]  
 b) Generate stiffness matrix and solve for the final end moments and reactions for the following frame loaded as shown in figure below. Also draw the bending moment diagram. [6+4+2]

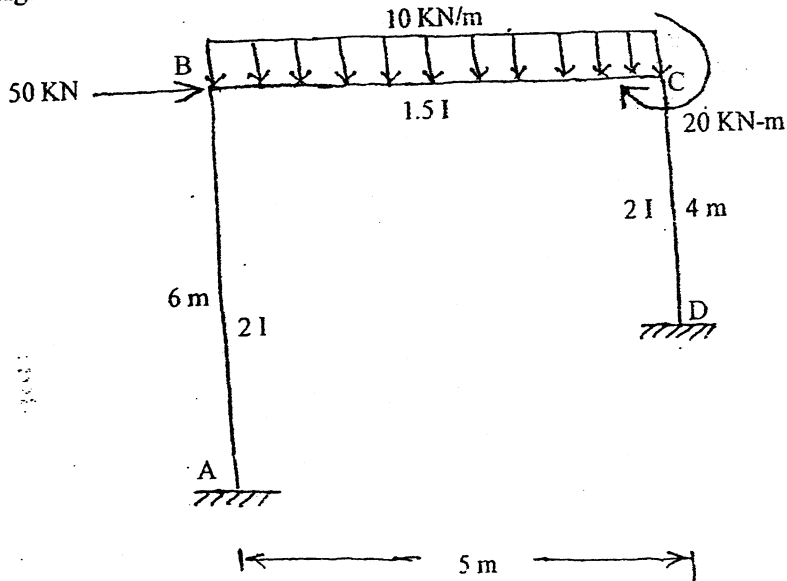

4. a) Draw influence line diagram for the moment at the fixed support a propped cantilever beam of span  $L$ . Find and plot the ordinate at  $0.2L$  interval. Use Mueller-Breslau principle. [6]  
 b) Analyse the frame loaded shown in figure below using the method of consistent deformation. Draw BMD and SFD. Consider  $EI$  to be constant throughout the frame. [10]

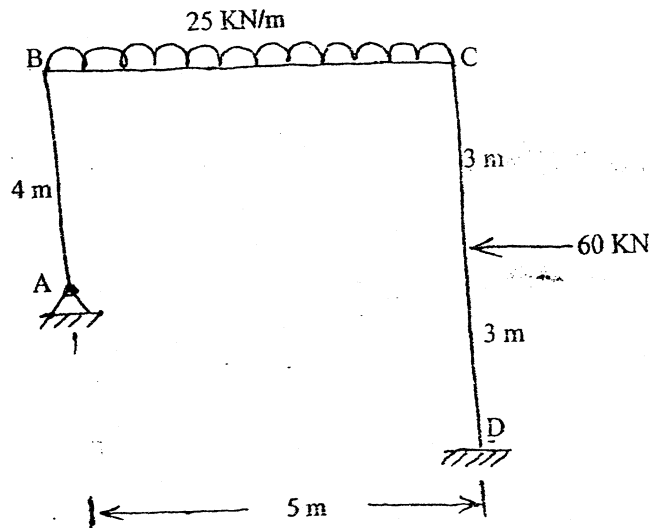

5. a) Derive three moment equation and explain its physical meaning. Explain with an example how the theorem can be used for a continuous beam with a clamed support at the end. [6]
- b) The portal frame shown in figure below is subjected to the factored loads. Determine the plastic moment of resistance. Also draw the statically admissible bending moment diagram. [10]

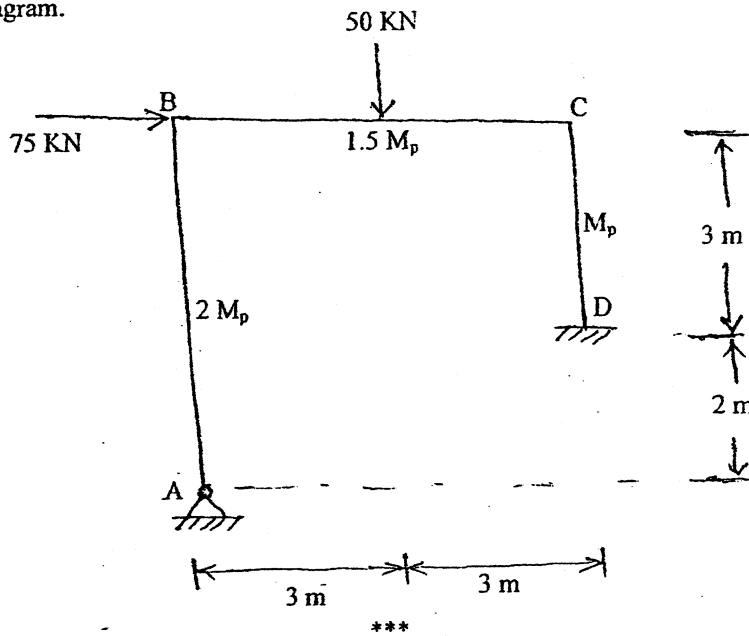



Exam.	New Back (2066 & Later Batch)		
Level	BE	Full Marks	80
Programme	BCE	Pass Marks	32
Year / Part	III / I	Time	3 hrs.

**Subject: - Theory of Structure II (CE601)**

- ✓ Candidates are required to give their answers in their own words as far as practicable.
- ✓ Attempt All questions.
- ✓ The figures in the margin indicate Full Marks.
- ✓ Assume suitable data if necessary.

1. a) Draw influence line diagram for moment at section x-x of the continuous beam shown in figure below. Find the ordinates at 2 m intervals. [5]

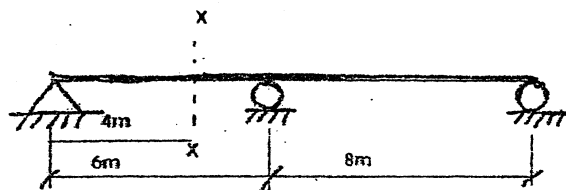

- b) Determine slope at A and deflections at D of the beam shown in figure below using castigliano's theorem. [10]

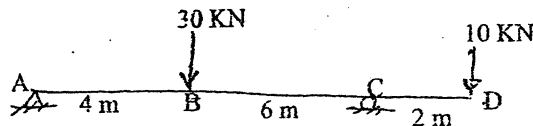

2. a) Define and explain the following terms: [5]

- i) Primary structure
- ii) Redundant force
- iii) Flexibility coefficient
- iv) Stiffness coefficient
- v) Kinematic indeterminacy

- b) Determine the forces in all members of the truss shown in figure below using force method. [12]

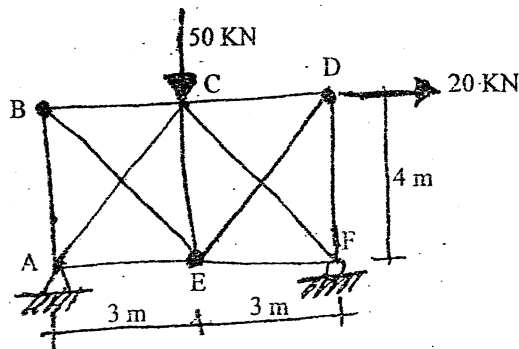

AE is constant for all members

3. a) Find the collapse load for portal frame shown in figure below.

[10]

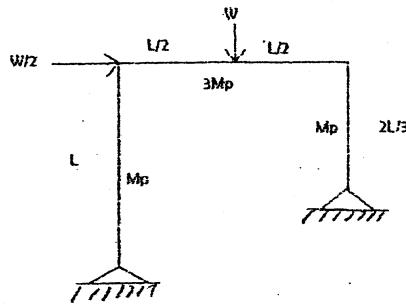

- b) Derive the expression of three moment theorem for continuous beam and explain its physical meaning.
4. a) Using flexibility matrix method, determine the reactions at support D of the frame loaded as shown in figure below. Also draw SFD and BMD. Take  $EI = \text{constant}$ .

[6]

[7]

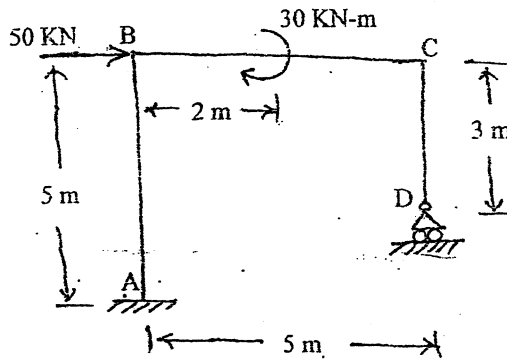

- b) Analyse the continuous beam shown in figure below using slope deflection method.

[10]

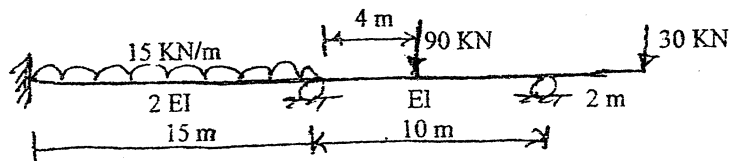

5. a) Derive the slope deflection equations.

[5]

- b) Using stiffness matrix method, draw bending moment diagram for the frame shown in figure below. Take constant  $EI$ .

[10]

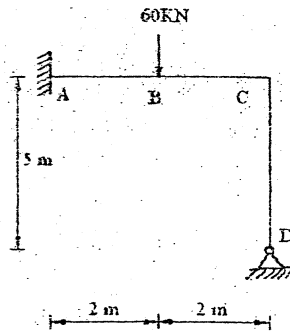

\*\*\*



Exam.	Regular		
Level	BE	Full Marks	80
Programme	BCE	Pass Marks	32
Year / Part	III / 1	Time	3 hrs.

*Subject: - Theory of Structure II (CE601)*

- ✓ Candidates are required to give their answers in their own words as far as practicable.
- ✓ Attempt All questions.
- ✓ The figures in the margin indicate Full Marks.
- ✓ Assume suitable data if necessary.

1. a) Draw influence diagram for vertical reaction at fixed support of a propped cantilever beam. Plot ordinates at 0.25 times span length. [4]
- b) Using Castigliano's theorem, find the deflection at point B of the beam shown in figure below. Take constant EI through the length. [12]

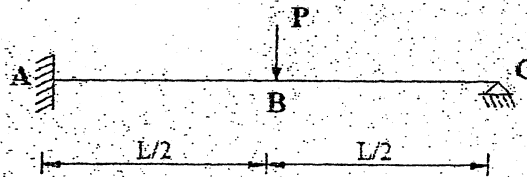

2. a) State and prove Maxwell's Reciprocal theorem. [4]
- b) Determine the bar forces and reactions that develop in the statically indeterminate truss shown in figure below. [12]

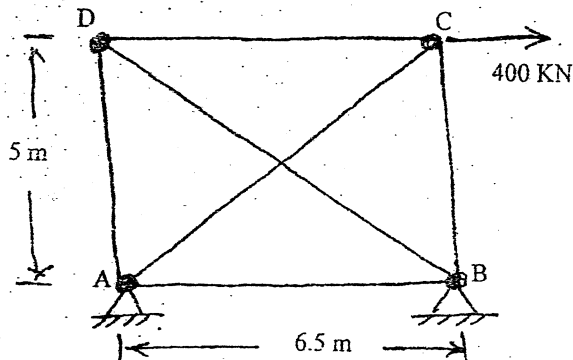

-Cross sectional Area:  
 Member BD = 20 cm<sup>2</sup>  
 Other members = 15 cm<sup>2</sup>  
 -Young's modulus = 240 × 10<sup>6</sup> KN/m<sup>2</sup>

3. a) Define plastic moment and shape factor. [3]
- b) Determine the reactions at support E and A and draw bending moment diagram of the frame shown in figure below by using flexibility matrix method (force method) [13]

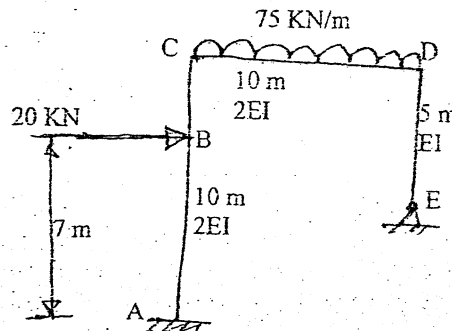

4. a) A propped cantilever beam of uniform  $M_p$  is loaded as shown in the figure below. Find the collapse load. [4]

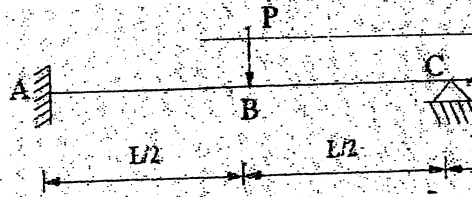

- b) Analyse the frame shown in figure below by using stiffness matrix method and draw bending moment diagram. [12]

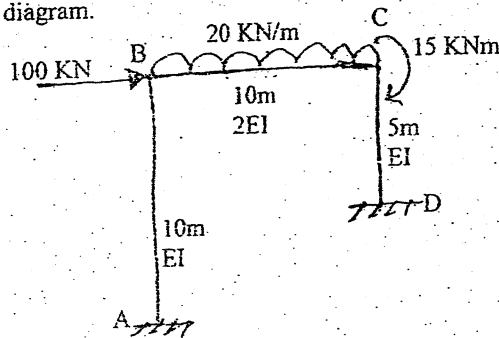

5. a) Define plastic hinge and explain how its length is determined. [4]

- b) Analyse the beam loaded shown in the figure below by slope deflection method. Also draw bending moment diagram (BMD) [12]

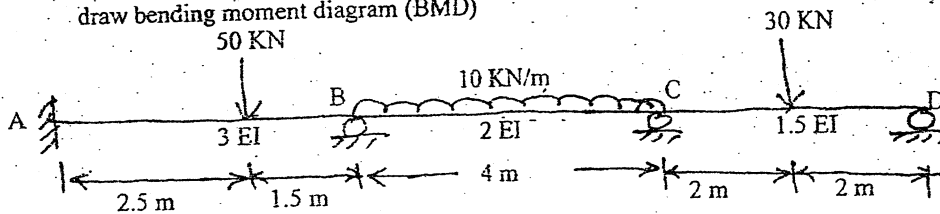

\*\*\*

Exam.	New Back (2066 & Later Batch)		
Level	BE	Full Marks	80
Programme	BCE	Pass Marks	32
Year / Part	III / I	Time	3 hrs.

Subject: - Theory of Structure II (CE601)

- ✓ Candidates are required to give their answers in their own words as far as practicable.
- ✓ Attempt All questions.
- ✓ The figures in the margin indicate Full Marks.
- ✓ Assume suitable data if necessary.

1. a) Draw influence line diagram for shear at the section x-x for the two-span continuous beam shown in the figure below. Draw the ordinate at 2 m interval. [6]

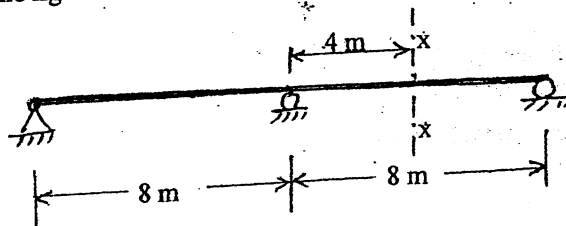

- b) A prismatic continuous beam ABCD is fixed at A and simply supported at B, C and D. It is subjected to factored loads as shown. Find the collapse mechanisms and draw BMD. [10]

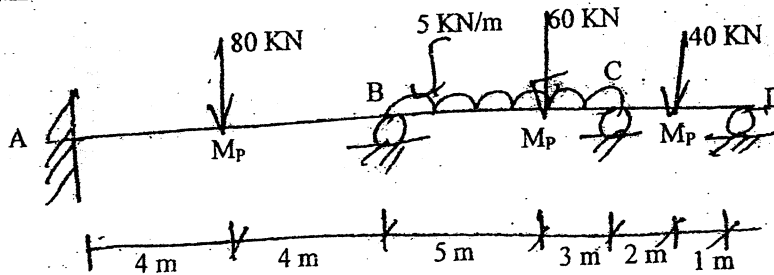

2. a) Using Castigliano's theorem, determine the moment at the fixed support A of the propped cantilever beam loaded as shown in figure below. [6]

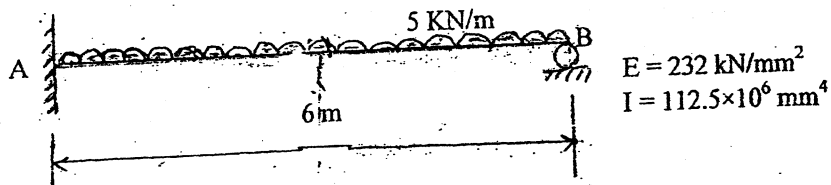

- b) Analyse the frame shown in figure below by using force method and draw bending moment diagram. [10]

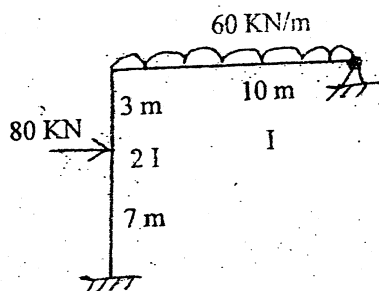

3. a) Analyse the frame shown in figure using stiffness matrix method. Consider only flexural deformations. [10]

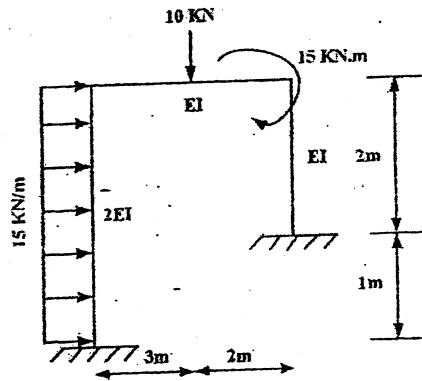

- b) List the differences between force and displacement methods. Draw a neat sketch of a system and explain. [6]
4. a) Determine the support moments and draw bending moment diagram of the continuous beam shown in figure below by using three moment equation. [7]

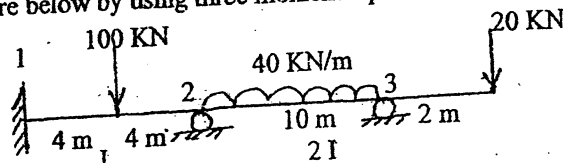

- c) Determine the forces in all members of the truss by using force method. AE is constant for all members. [7]

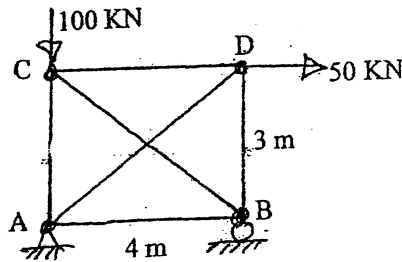

- b) Write down the boundary conditions for a single span beam fixed at both ends. [2]
5. Analyse the frame shown in figure below by using moment distribution method. [15]

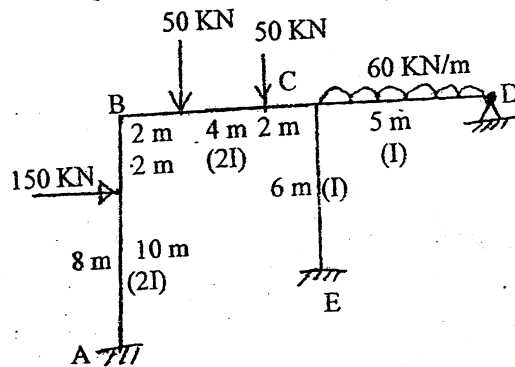

\*\*\*

Exam.	Regular		
Level	BE	Full Marks	80
Programme	BCE	Pass Marks	32
Year / Part	III / II	Time	3 hrs.

**Subject: - Theory of Structure II (CE601)**

- ✓ Candidates are required to give their answers in their own words as far as practicable.
- ✓ Attempt All questions.
- ✓ The figures in the margin indicate Full Marks.
- ✓ Assume suitable data if necessary.

1. a) Draw influence line diagram for moment at support 2 of the continuous beam shown in figure below by using focal point method. Find ordinates at 4 m interval, in span 1-2 and at 2m interval on span 2-3 [6]

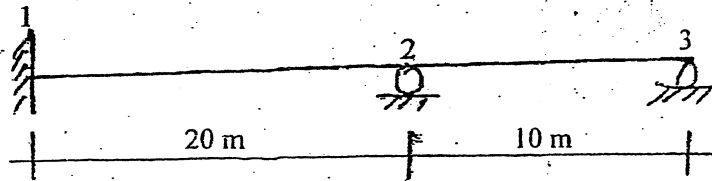

- b) Find the collapse load for portal frame shown in figure below. [10]

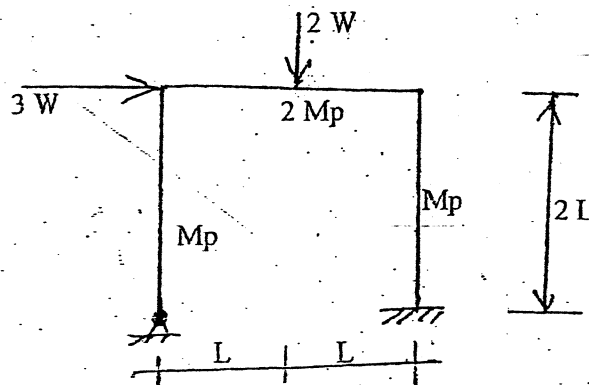

2. a) Determine the moment at fixed support of the propped cantilever beam using Castigliano's method. [6]

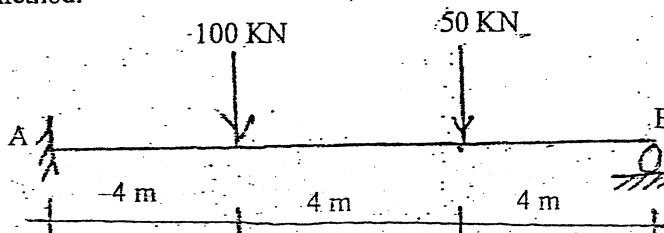

- b) Generate flexibility matrix to determine the reactions at support D for the frame loaded shown in the figure below. Also determine the reactions at support D and draw bending moment diagram. Show all the steps. [10]

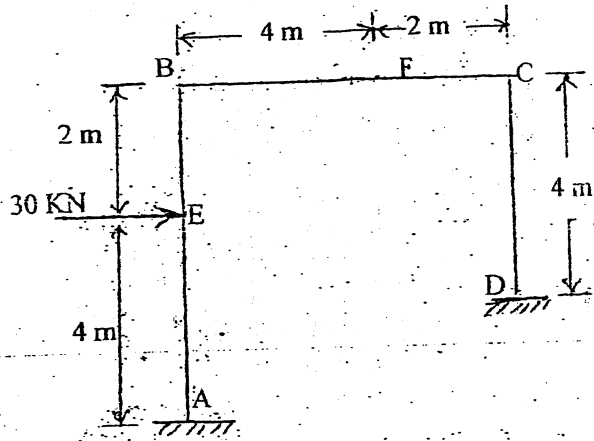

3. a) Analyse the frame shown in figure below by using stiffness matrix method and draw bending moment diagram. [10]

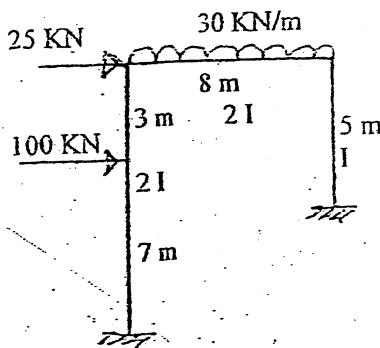

- b) List the properties of stiffness and flexibility matrices for a given system. Draw a neat sketch of a system and explain. [6]

4. a) Using the consistent deformation method analyse the frame shown in figure and draw bending moment, shear force and normal thrust diagram. [15]

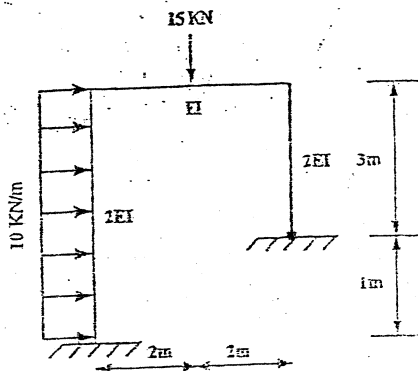

- b) Draw a propped cantilever and write down its boundary conditions. [2]

Exam.	New Back (2066 & Later Batch)		
Level	BE	Full Marks	80
Programme	BCE	Pass Marks	32
Year / Part	III / I	Time	3-hrs.

*Subject: - Theory of Structure II (CE601)*

- ✓ Candidates are required to give their answers in their own words as far as practicable.
- ✓ Attempt All questions.
- ✓ The figures in the margin indicate Full Marks.
- ✓ Assume suitable data if necessary.

1. a) Obtain the degree of static and kinematic indeterminacies for the given structures. [3+2]

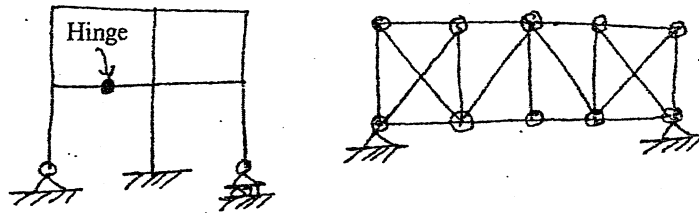

- b) Determine reaction at B of the propped cantilever beam shown in figure below using Castigliano's theorem. Also draw bending moment diagram. [10]

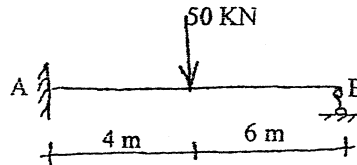

2. a) Explain why flexibility method is called a Force Method. using Force method determine the reactions in the continuous beam shown in figure below, if support B settles 18 mm and support C settles 12 mm. Given EI is constant.  $E = 232 \text{ KN/mm}^2$ , and  $I = 112.5 \times 10^6 \text{ mm}^4$ . [3+7]

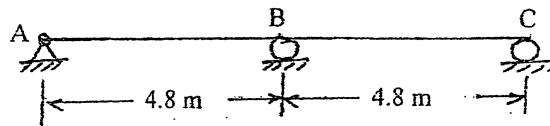

- b) Explain the physical meaning of compatibility condition and derive the equation for it. A portal frame with hinged supports is subjected to a temperature variation as shown in figure below. Determine flexibility coefficients and calculate redundant force with the help of compatibility equation. Take  $\alpha = 11 \times 10^{-6} / ^\circ\text{C}$ ,  $E = 5000 \sqrt{f_{ck}}$ ,  $f_{ck} = 20 \text{ MPa}$  and constant flexural rigidity. [15]

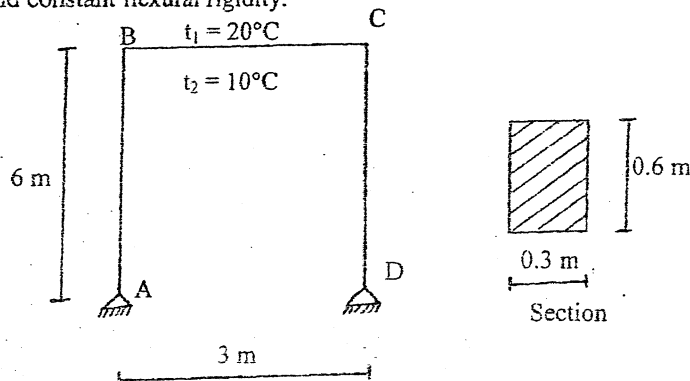

3. a) Generate stiffness matrix for the frame given below. Use the stiffness matrix generated to draw bending moment diagram. Take  $EI$  as constant for all members. [15]

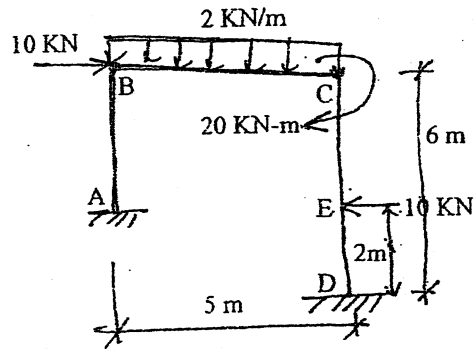

- b) Analyse the frame shown in figure below by using moment distribution method. Draw bending moment diagram. [10]

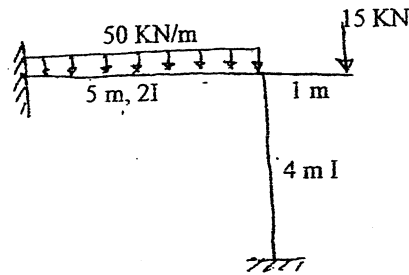

4. a) Explain influence line diagram as system specific diagram. Derive the expression of recurrent formula for focal point ratio considering two consecutive spans for loading on right spans. [5]

- b) For the given portal frame with same plastic moment capacity  $M_p$  for all members calculate the value of  $P$  at collapse. [10]

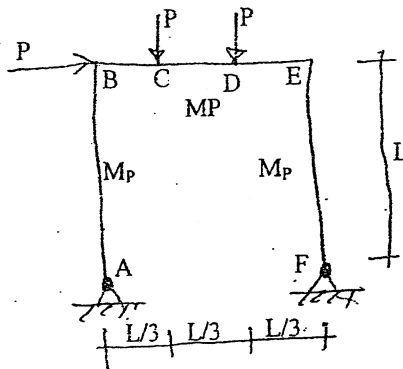

\*\*\*



01 TRIBHUVAN UNIVERSITY  
INSTITUTE OF ENGINEERING  
Examination Control Division  
2070 Chaitra

Exam.	Regulation		
Level	BE	Full Marks	80
Programme	BCE	Pass Marks	32
Year / Part	III / I	Time	3 hrs.

Subject: - Theory of Structure II (CE601)

- ✓ Candidates are required to give their answers in their own words as far as practicable.
- ✓ Attempt All questions.
- ✓ The figures in the margin indicate Full Marks.
- ✓ Assume suitable data if necessary.

1. a) Describe different types of indeterminacies of the structural system and their physical meanings. [5]
- b) Use castigliano's theorem to determine forces induced in each members of the square truss loaded as shown below. [10]

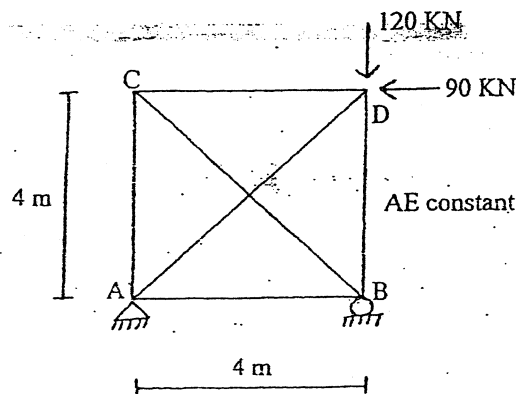

2. a) Draw shear force and bending moment diagrams for the frame given below. Use force method. [15]

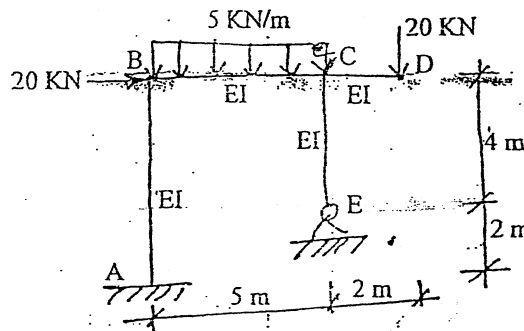

- b) Determine the horizontal reaction in the two hinged parabolic arch shown figure below. Also determine the bending moment at C. ( $I = I_c \sec\theta$ ) [10]

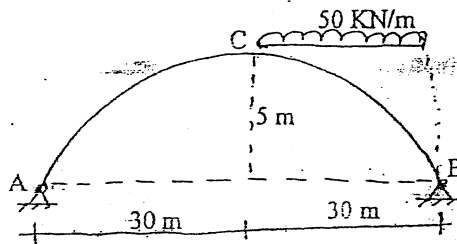

3. a) Describe with example the principle of moment distribution. For the frame shown in figure below generate stiffness matrix that operates on displacements  $u_1, v_1, \theta_1$  and  $\theta_2$ . Both members are slender and have the same  $E, I, A$  and  $L$ . Express matrix coefficients in terms of  $L, a = AE/L$  and  $b = EI/L^3$  [5+10]

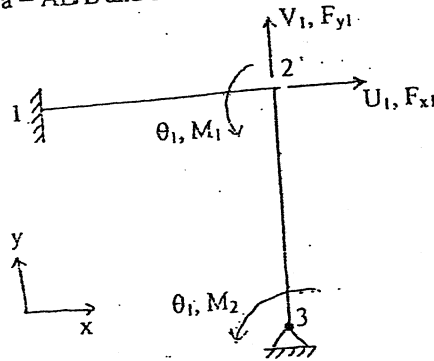

- b) A jib-crane is carrying vertical load of 10 kN at A as shown in figure below. Determine by matrix displacement method, the displacement of joint A and hence calculate the forces in members AB and AC. Take cross-sectional area of members AB and AC as  $10000 \text{ mm}^2$  and  $20000 \text{ mm}^2$  respectively and  $E = 200 \text{ kN/mm}^2$ . [10]

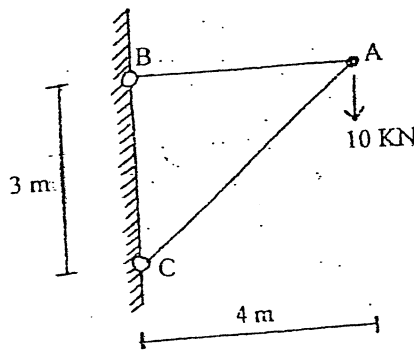

4. a) Draw influence line diagram for the shear at section 2-2 of the propped cantilever beam shown in figure below. Find the ordinates at 2 m interval. [5]

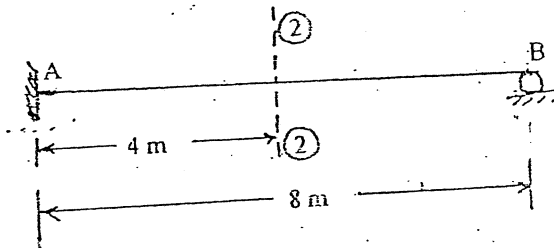

- b) Find the plastic moment capacity of the frame shown figure below during collapse. [10]

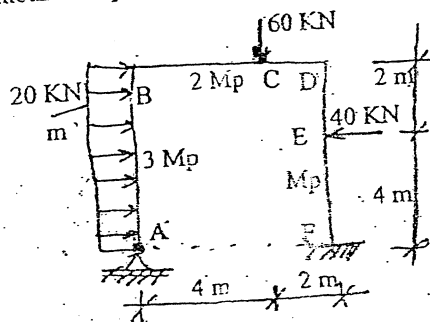

05 TRIBHUVAN UNIVERSITY  
 INSTITUTE OF ENGINEERING  
**Examination Control Division**  
 2070 Chaitra

<b>Exam.</b>	<b>Old Back (2065 &amp; Earlier Batch)</b>		
<b>Level</b>	BE	<b>Full Marks</b>	80
<b>Programme</b>	BCE	<b>Pass Marks</b>	32
<b>Year / Part</b>	III / I	<b>Time</b>	3 hrs.

**Subject: - Theory of Structure II (EG622CE)**

- ✓ Candidates are required to give their answers in their own words as far as practicable.
- ✓ Attempt any Four questions.
- ✓ The figures in the margin indicate Full Marks.
- ✓ Assume suitable data if necessary.

1. a) Determine degrees of static and kinetic indeterminacies for the frame shown below. [6]

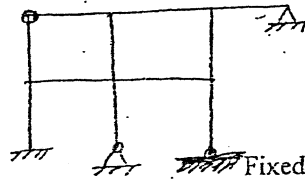

b) Find the reaction at the propped end of a propped cantilever beam of span L and loaded with uniformly distributed load w per unit length over the whole span by using castigliano's theorem. [6]

c) Compute the reactions and draw shear force and bending moment diagram for the frame shown in figure below. Use consistent deformation method. [8]

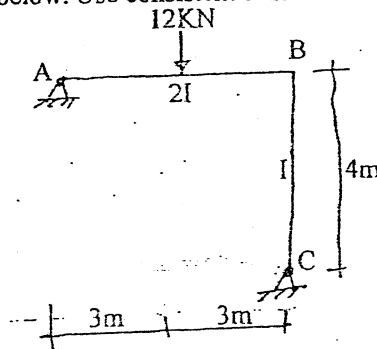

2. a) Explain compatibility conditions. Also describe Maxwell's reciprocal theorem. [2+2]

b) In two hinged parabolic arch shown below, find the values of bending moment normal thrust and radial shear at section D due to the given loading and due to yielding of support B by 10 mm. Take  $EI_c = 100 \times 10^6 \text{ KNm}^2$ .  $I = I_c \sec\theta$ . Also draw bending moment diagram. [16]

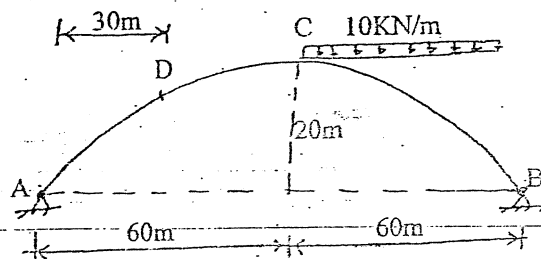

3. a) Define the terms flexibility and stiffness. [2+2]

b) Analyse the continuous beam shown in figure below by slope deflection method. Support B sinks by 7.5 mm. Support A rotates by 5° anticlockwise  $E = 5 \times 10^5 \text{ MPa}$ ,  $I = 3 \times 10^7 \text{ mm}^4$ . [16]

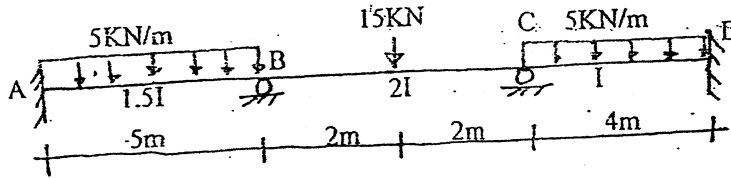

4. a) Define carry over factor and distribution factor. [4]

b) Analyse the frame shown in figure below using moment distribution method. Also draw shear force, axial force and bending moment diagram. [16]

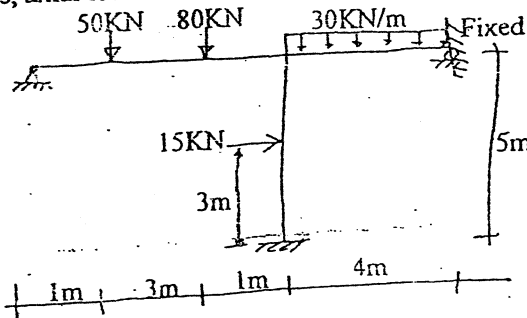

5. a) Define Muller-Breslau principle. Draw influence line diagram for reaction at C. Find ordinates at 2 m interval. [2+8]

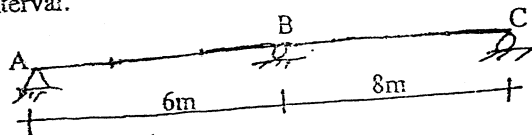

b) Define the following terms: [6]

(i) Shape factor (ii) Load factor (iii) Plastic hinge

c) Determine the collapse load for a propped cantilever beam shown below. Plastic moment capacity is  $M_p$ . [4]

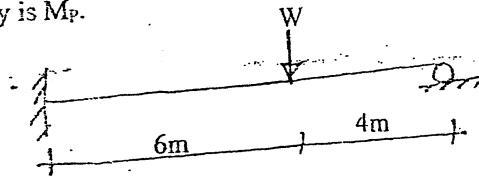

\*\*\*

LEVEL	SEM	FULL MARKS	OV
Programme	BCE	Pass Marks	32
Year / Part	III / I	Time	3 hrs.

**Subject: - Theory of Structures II (CE601)**

- ✓ Candidates are required to give their answers in their own words as far as practicable.
- ✓ Attempt All questions.
- ✓ The figures in the margin indicate Full Marks.
- ✓ Assume suitable data if necessary.

1. a) Define degree of static and degree of kinematic indeterminacies with suitable examples. [4]
- b) Determine the external and internal degrees of static indeterminacy of the structure shown in figure below. Also determine the kinematic indeterminacy. [3+3]

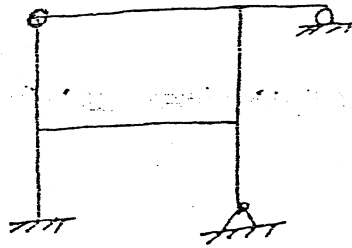

- c) Determine the moment at the fixed end of a propped cantilever beam shown in figure below using Castigliane's theorem. [5]

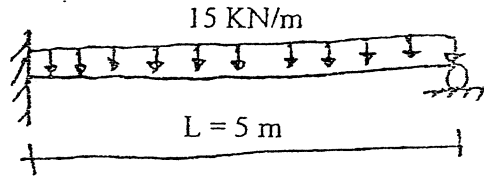

2. a) Define force method and primary structure. [4]
- b) Generate flexibility matrix for the coordinates shown in figure below. [6]

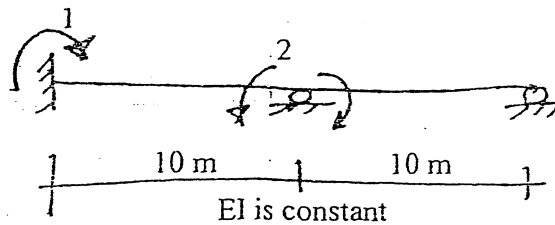

- c) Determine horizontal and vertical reactions at support D of the frame shown in figure below using force method. [10]

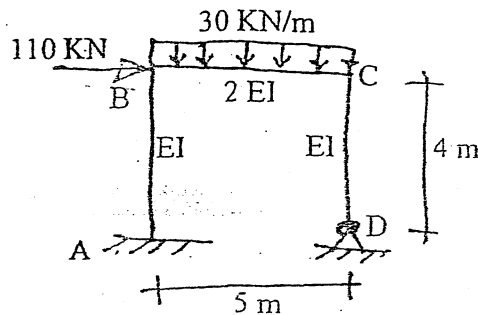

OR

Analyse the continuous beam shown in figure below by using three moment theorem.

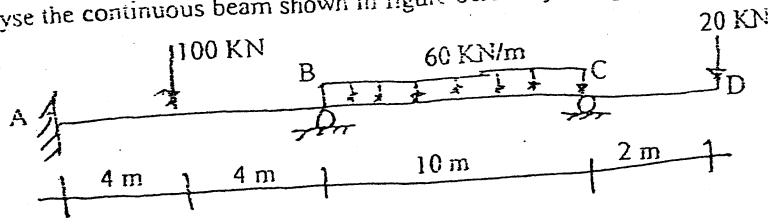

Draw shear force and bending moment diagram.

- d) Determine the force in member BF of the redundant truss shown in figure below. Cross section areas of each member in  $\text{cm}^2$  are given in figure within brackets. [5]

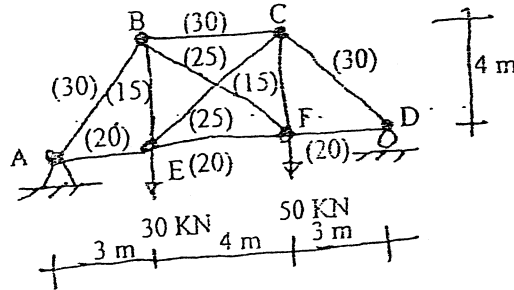

OR

Draw bending moment (BM) diagram for the two hinged parabolic arch shown  $I = I_c \sec \theta$ . Calculate the BM value at an interval of 10 m.

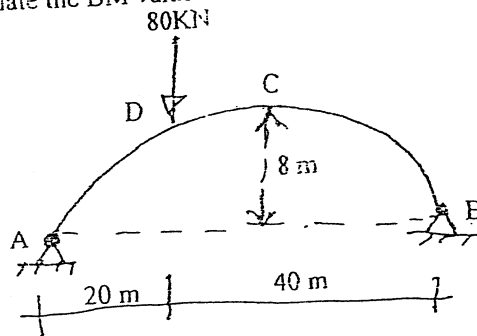

3. a) Generate stiffness matrix for the frame shown in figure below. [5]

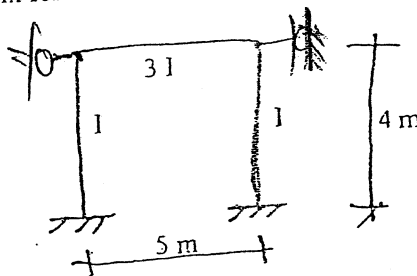

- b) Analyse the continuous beam and draw bending moment diagram which is loaded as shown in figure below. Use stiffness matrix method. [10]

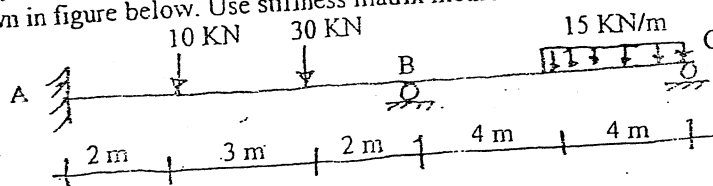

70A  
TOS-II

- c) Use moment distribution method to analyse the frame loaded as shown in figure below. Also draw bending moment diagram. [10]

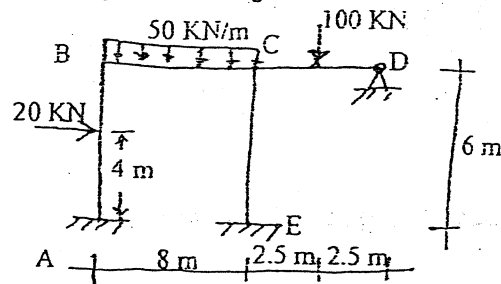

4. Define focal point ratio and derive expression to determine left focal point ratio. [7]

OR

Draw influence line diagram for reaction at support B of the propped cantilever beam shown in figure below. Determine ordinates at 3 m interval.

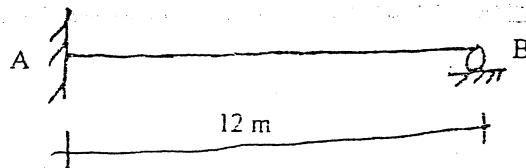

5. Determine the collapse load for the two span beam shown in figure below if the plastic moment capacity is  $M_p$ . [8]

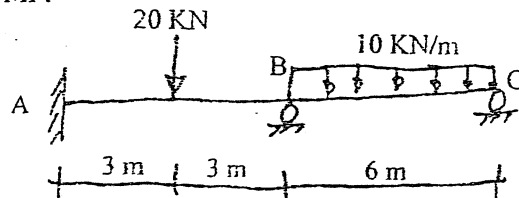

\*\*\*

TOP  
TCS-II

Exam.	New Exam 2069 Ashad		
Level	BE	Full Marks	80
Programme	BCE	Pass Marks	32
Year / Part	III / I	Time	3 hrs.

**Subject: - Theory of Structure II (CE 601)**

Candidates are required to give their answers in their own words as far as practicable.

Attempt All questions.

The figures in the margin indicate Full Marks.

Assume suitable data if necessary.

- a) Explain static and kinematic indeterminacies of structures. Determine the degrees of static and kinematic indeterminacy of the structure shown in figure below. (Take all members are inextensible). [2+2+2]

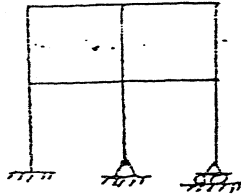

- b) Using Castigliano's second theorem. Determine the slope at A of the beam shown in figure below. EI is constant. [4]

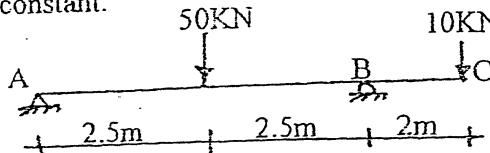

- c) Define flexibility and stiffness. What are the properties of flexibility matrix? [2+3]

- a) Use force method (flexibility matrix) to find the reactions at supports B and C of the beam shown in figure below and also draw shear force and bending moment diagrams. [10]

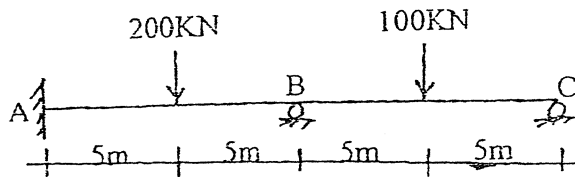

- b) A two hinged symmetrical parabolic arch of secant variation cross section having span 50m and rise 8m is loaded with a uniformly distributed load of 12kN/m extending from the left hand support to the centre of the arch as shown in figure below. Determine the horizontal reaction at the support. [5]

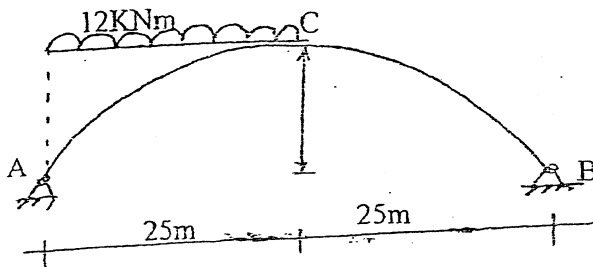

- c) Generate flexibility matrix for the coordinates shown in figure below and use this to determine the reactions at support D. Take EI is constant for all members. [10]



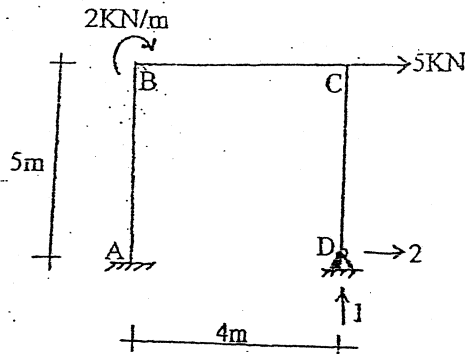

3. a) Generate stiffness matrix for the frame shown in figure below with respect to coordinates 1, 2 and 3 and use it to analyse the frame if the forces 5 kNm and 4 kN are acting at coordinates 1 and 3 respectively in addition to the external loads as shown in figure below. Take  $EI$  is constant for all members.

[10]

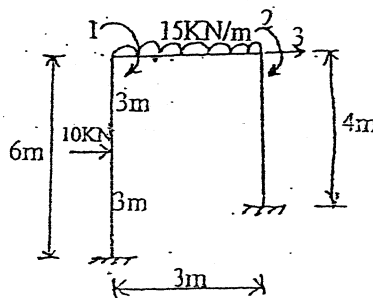

OR

- Analyse the continuous beam shown in figure below by slope deflection method. Also draw shear force and bending moment diagram.

[10]

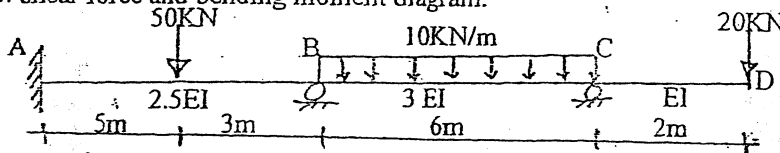

- b) Analyse the frame loaded as shown in figure below using moment distribution method and draw bending moment diagram. Take  $EI$  is constant.

[10]

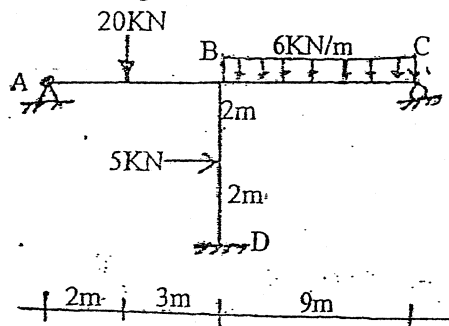

- c) Use displacement method (Stiffness matrix) to find forces in members of the truss shown in figure below. Take axial stiffness for each member to be  $400 \text{ kNcm}^{-1}$ .

[5]

63 R  
TOS - D

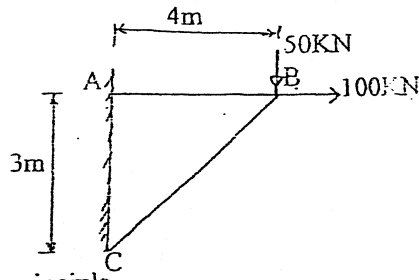

4. a) Define Mueller Breslau principle. [2]  
 b) Draw influence line diagram for the reaction at B of the propped cantilever beam shown in figure below. Find the ordinates at 2m interval. [5]

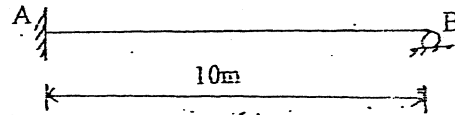

5. a) Define load factor, shape factor and plastic hinge. [3]  
 b) For the given continuous beam with the same plastic moment of resistance  $M_p$  for all the members. Calculate the value of P at collapse. [5]

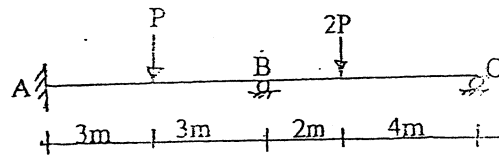

OR

Calculate the collapse moment after establishing possible failure mechanisms for the portal frame shown in figure below. Use load factor 1.75. [8]

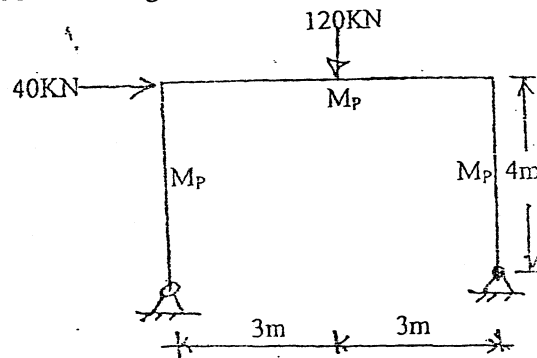

\*\*\*

Exam.	Regular		
Level	BE	Full Marks	80
Programme	BCE	Pass Marks	32
Year / Part	III / I	Time	3 hrs.

*Subject: - Theory of Structures II (CE601)*

- ✓ Candidates are required to give their answers in their own words as far as practicable.
- ✓ Attempt All questions.
- ✓ The figures in the margin indicate Full Marks.
- ✓ Assume suitable data if necessary.

1. a) What is structural idealization? Explain necessary and sufficient condition for stability of a truss. [5]
- b) Use Castigliano's theorem to find moment at point C of the propped cantilever beam loaded as shown in the figure below. Take EI to be constant. [10]

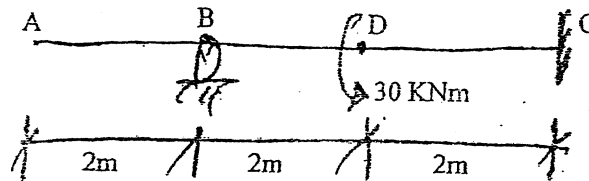

2. (a) Derive expressions for support moments of a single span fixed beam when one end of the beam rotates by an angle  $\theta$ . Also determine the expressions for support moments of the same beam when one end of the beam settles down by  $\Delta$ . Assume EI as the cross sectional stiffness and L the span. [7]
- b) Find out member forces in the truss shown in figure below using force method. The axial rigidity of all vertical and horizontal members in EA and that for all inclined member is 2EA. [18]

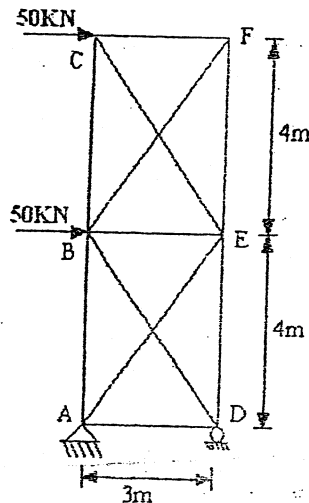

3. a) Derive three moment theorem for a continuous beam and explain its physical meaning. [7]
- b) Determine element stiffness matrices, deformations at joints and member forces. Also draw bending moment diagram, using stiffness matrix method. [18]

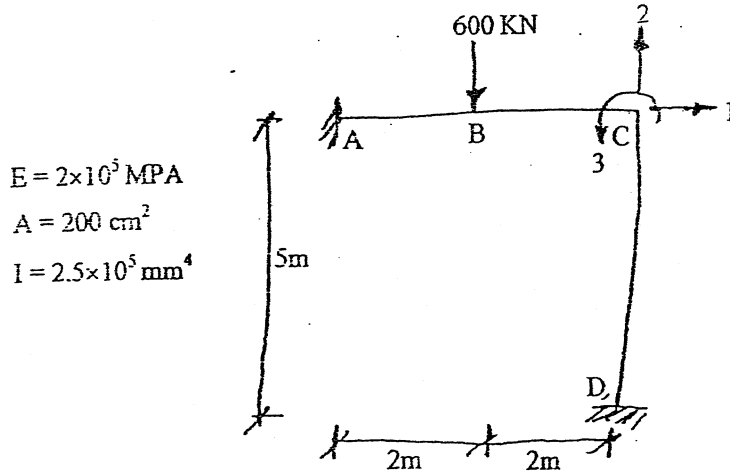

- 4) Define and explain what is neutral point in an unloaded span of a continuous beam. Derive recurrent formula for its determination. [5]

5. a) Enunciate the two basic theorems on methods of limit in plastic analysis. [4]
- b) A prismatic continuous beam ABCD is fixed at A and simply supported at B, C and D. It is subjected to factored loads as shown in figure below. Find collapse mechanism and draw BM diagram. [6]

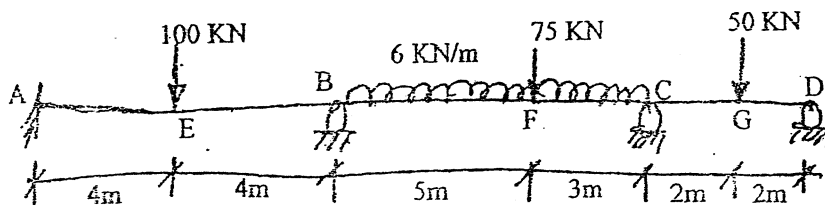

\*\*\*

EGC  
TOS-II

Exam.	Regular		
Level	BE	Full Marks	80
Programme	BCE	Pass Marks	32
Year / Part	III / I	Time	3 hrs.

*Subject: - Theory of Structure II (CE 601)*

- ✓ Candidates are required to give their answers in their own words as far as practicable.
- ✓ Attempt any Five questions.
- ✓ The figures in the margin indicate Full Marks.
- ✓ Assume suitable data if necessary.

1. a) Explain with a simple example the steps to follow in solving a frame using displacement method. [8]
- b) Use force method (flexibility matrix) to solve the truss as shown in figure below. [8]

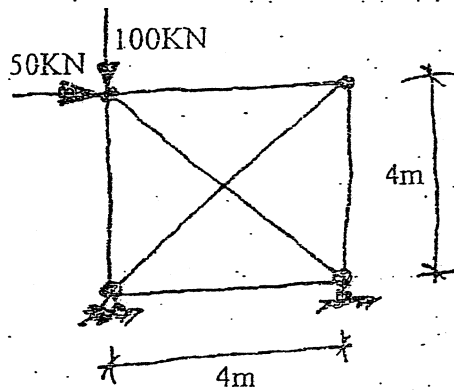

2. Analyse the beam shown in figure below by slope deflection method. Draw BM diagram considering given external loading and rotation of support D by  $(1/10)$  clockwise, support C settles down by 4mm. [16]

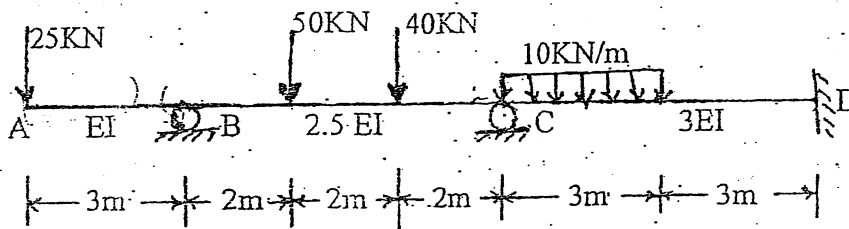

3. a) What is Muceller Breslau principle and how it is used to determine the shape of an influence line diagram of a structural quantity in a statically indeterminate beam? Shown in a simple example. [8]

- b) For the given portal frame with same plastic moment of resistance  $M_p$  for all the members, calculate the value of  $p$  at collapse. [8]

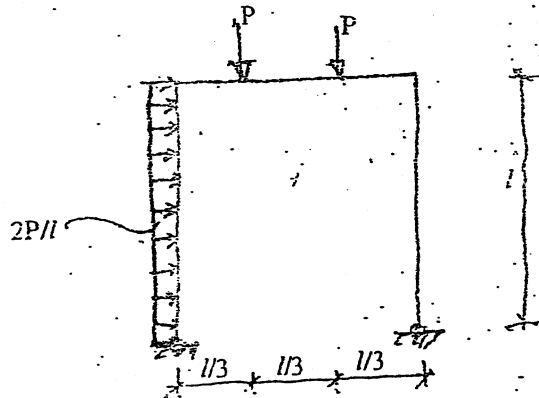

4. a) For the beam as shown, determine the slope at support B. Use Castigliano's second theorem. Take  $EI = \text{constant}$ . [5]

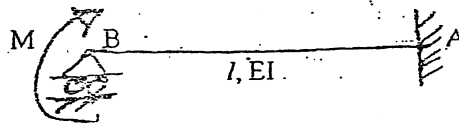

- b) Determine the Static indeterminacy (external/internal) and kinematic indeterminacy for the structure as shown. [3]

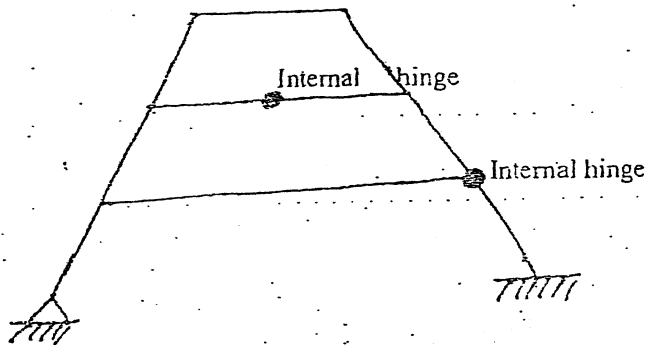

- c) Using Castigliano's second theorem, determine the vertical deflection at the 50 kN load in the beam shown in figure below. [8]

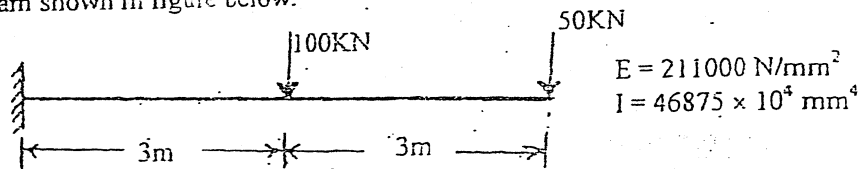

5. a) Enunciate and explain with its uses the two basic theorems on methods of limit analysis in plastic analysis for bending. [8]

TRIBHUVAN UNIVERSITY  
INSTITUTE OF ENGINEERING  
**Examination Control Division**  
2079 Bhadra

Exam.	Regular		
Level	BE	Full Marks	80
Programme	BCE	Pass Marks	32
Year / Part	III / I	Time	3 hrs.

***Subject: - Concrete Technology and Masonry Structure (CE 603)***

- ✓ Candidates are required to give their answers in their own words as far as practicable.
- ✓ Attempt **All** questions.
- ✓ The figures in the margin indicate **Full Marks**.
- ✓ **IS 1905-1987 and NBC 109-1994 are allowed to use.**
- ✓ Assume suitable data if necessary.

1. a) What is bulking of aggregate? How can its effect controlled during manufacture of concrete? [6]
- b) Describe concrete as three phase system and explain the structure of hcp in concrete. [6]
- c) Briefly explain the Bogue's compound of cement. [4]
2. a) Explain the steps of concrete mix design based on DoE Method used in concrete. [8]
- b) During concreting, how would you maintain the quality control in site? [4]
- c) List out the properties of hardened concrete. Describe the elastic behavior of hardened concrete. [4]
3. a) Calculate the compressive strength of cement, when 300 gm of cement is mixed with 150 gm of water. Consider: Case I- Cement is fully hydrated, Case II- 60% of Cement is hydrated. [6]
- b) Explain the procedures of compressive strength test of concrete. What are the acceptance criteria of test results? [4+2]
- c) Explain on uses and advantages of Hollow Blocks and Compressed Earth Blocks. [4]
4. a) A wall 20 cm thick, using modular bricks carries at the top a load of 100 kN/m having resultant eccentricity of 1/12. Wall is 5 m long between cross wall and is of 3.4 m clear height between RCC slabs at top and bottom. What should be the required strength of brick and grade of mortar? Assume that joints are not raked. [10]
- b) Explain various types of Brick bonds with neat sketches. What are the advantages and disadvantages of Rat Trap Bond in masonry structure? [6]
5. a) A column section 400 mm × 800 mm carries load 250 kN acting at 160 mm from the 800 mm face and 350 mm from the 400 mm face. Determine the stress intensities at all four corners. [8]
- b) Explain the procedure to test brick masonry prism in laboratory. [6]
- c) Explain lateral load resisting system of masonry structures. [2]

\*\*\*





TRIBHUVAN UNIVERSITY  
INSTITUTE OF ENGINEERING  
**Examination Control Division**  
2079 Baishakh

Exam.	Back		
Level	BE	Full Marks	80
Programme	BCE	Pass Marks	32
Year / Part	III / I	Time	3 hrs.

**Subject: - Concrete Technology and Masonry Structure (CE 603)**

- ✓ Candidates are required to give their answers in their own words as far as practicable.
- ✓ Attempt All questions.
- ✓ The figures in the margin indicate Full Marks.
- ✓ IS: 1905-1987 is allowed.
- ✓ Assume suitable data if necessary.

1. a) Explain the advantages of concrete. Explain cause, effect and remedial measure for bulking of sand. [4+4]
- b) Describe concrete as three system and explain the structure of hcp in concrete. [6]
2. a) Explain workability of concrete mix. How it impacts the quality of the concrete? [6]
- b) What are nominal mix and design mix in concrete? Write down the steps for mix design by IS method. [2+6]
3. a) Describe physical properties of hardened concrete. [8]
- b) Explain non-destructive tests in concrete. [6]
- c) Calculate the gel/space ratio and the theoretical strength of a sample concrete made with 550 gm of cement with 0.45 water/cement ratio, on full hydration and at 60 percentage hydration. How water cement ratio affects the durability of concrete? [4+2]
4. a) Write down the use of masonry structure. Write down the construction techniques to be considered while constructing brick masonry. [4+4]
- b) A wall 250 mm thick, using modular bricks carries at the top a load of 350 kN/m having resultant eccentricity ratio of 1/12. Wall is 5 m long between cross walls and is 3.5 m clear height between RCC slabs at the top and bottom. What shall be the strength of brick and the grade of mortar? Assume that joints are not raked. [12]
5. a) A column section 450 mm × 750 mm carries a load 150 kN acting with eccentricity of 50 mm along 750 mm and 45 mm along 450 mm from centrid. Calculate the stress intensities at all four corners. [6]
- b) Explain flat jack test in masonry structures. [6]

\*\*\*



TRIBHUVAN UNIVERSITY  
INSTITUTE OF ENGINEERING  
**Examination Control Division**  
2078 Kartik

Exam.	Back		
Level	BE	Full Marks	80
Programme	BCE	Pass Marks	32
Year / Part	III / I	Time	3 hrs.

**Subject:** - Concrete Technology and Masonry Structure (CE 603)

- ✓ Candidates are required to give their answers in their own words as far as practicable.
- ✓ Attempt All questions.
- ✓ The figures in the margin indicate Full Marks.
- ✓ IS 1905: 1987 is allowed.
- ✓ Assume suitable data if necessary.

1. a) Write down the properties of aggregates for concrete. How do the aggregate properties influence the concrete properties? [4+4]  
b) Describe three phase system of concrete. Explain the role of aggregate phase. [4+2]
2. a) Describe the ways of determining the workability of a concrete mix in lab. [6]  
b) Explain the process of concrete mix design based on ACI Method. [8]
3. a) Explain shrinkage and creep in concrete. [4+4]  
b) Explain the variability of concrete strength and acceptance criteria. [6]  
c) Write down the physical and chemical causes of concrete deterioration. [6]
4. a) Explain the main elements that resist the lateral loads in buildings. Explain with sketches. [8]  
b) External wall of a single storeyed building is 23 cm thick and carries 100 kN/m load at the top of the wall with the eccentricity of 12 mm. The plinth level is 1.5 m above the top of foundation footing and floor to ceiling height is 3.0 m. RCC slab bears on the wall and is 12 cm thick. Determine the maximum stress in the wall and calculate the strength of brick and grade of mortar required for the wall. Assume necessary data if any required. [12]
5. a) A column section 400 mm × 800 mm carries load 250 kN acting at 160 mm from the 800 mm face and 350 mm from the 400 mm face. Determine the stress intensities at all four corners. [6]  
b) Explain nondestructive tests in masonry. [6]

\*\*\*

Exam.	Regular		
Level	BE	Full Marks	80
Programme	BCE	Pass Marks	32
Year / Part	III / I	Time	3 hrs.

**Subject: - Concrete Technology and Masonry Structure (CE 603)**

- ✓ Candidates are required to give their answers in their own words as far as practicable.
- ✓ Attempt All questions.
- ✓ The figures in the margin indicate Full Marks.
- ✓ IS 1905-1987 and NBC 109-1994 are allowed to use.
- ✓ Assume suitable data if necessary.

1. a) Define nominal size, single size and maximum sizes of aggregate with example. Why is grading of aggregate important with regard to the properties of concrete? [6]
- b) Describe concrete as three phase system. [6]
- c) Discuss about the compressive strength test on the brick wall. [4]
2. a) Explain the steps of concrete mix design based on DOE Method used in concrete. [8]
- b) What are the measures of workability? What is the role of water cement ratio to the workability, strength and durability of concrete? [4]
- c) Describe dynamic and static modulus of elasticity of concrete. [4]
3. a) Explain various strength of concrete. [4]
- b) You are site in charge for quality control of concrete at site and discuss the steps you follow to maintain the quality of concrete. Also elaborate the non-destructive test by rebound hammer. [2+4]
- c) Discuss the relation between water and permeability on concrete durability. Write the corrosion on steel and its remedial measure. [6]
4. a) A 23 cm thick brick Masonry wall carries an axial load of 12 Kn per meter length and eccentric load 27Kn per meter length acting at distance 7.33 cm from the axis of wall. Design the masonry wall if its slenderness ratio 16, assume that joints are non-raked. [8]
- b) Find the minimum strength of masonry unit and mortar type for a column 200 mm × 400 mm size to support 120 KN load with an eccentricity of 50 mm. The clear height of the column is 3m and fully restrained at both ends. [8]
5. a) Describe the scope of masonry structures. [2]
- b) Explain with figure, failure behavior of masonry structures in lateral loads. What is in-plane and out of plane behavior of masonry structure. [5+3]
- c) Explain flat jack test and push shear test in masonry with figure. [3+3]

TRIBHUVAN UNIVERSITY  
INSTITUTE OF ENGINEERING  
**Examination Control Division**  
2076 Chaitra

Exam.	Regular		
Level	BE	Full Marks	80
Programme	BCE	Pass Marks	32
Year / Part	III / I	Time	3 hrs.

**Subject:** - Concrete Technology and Masonry Structure (CE 603)

- ✓ Candidates are required to give their answers in their own words as far as practicable.
- ✓ Attempt **All** questions.
- ✓ The figures in the margin indicate **Full Marks**.
- ✓ **IS 1905-1987 and NBC109-1994 are allowed to use.**
- ✓ Assume suitable data if necessary.

1. a) Describe the use of concrete in structure. How does fineness modulus of aggregate impact? [4+2]
- b) What do you know about 3 phases of concrete? Explain the effect of transition zone on concrete properties. [2+2]
- c) Describe the NDT test for Masonry Structure. [6]
2. a) Describe the stepwise process of mixed-design of concrete by ACI method. [8]
- b) Explain segregation and bleeding along with their causes. [4]
- c) Explain the properties of hardened concrete. [4]
3. a) What are the acceptance criteria while testing of concrete? [4]
- b) Explain the methods of non-destructive testing of concrete. [6]
- c) Explain chemical causes of concrete deterioration. [6]
4. a) Explain various factors to be considered in design of masonry. [4]
- b) A wall 230 mm thick, using local bricks carries 135 kN/m load at top of wall having eccentricity ratio of 1/12. Wall is 4m long between cross walls and is 3m clear height between RCC slab at bottom and timber flooring top. What shall be the strength of brick and grade of mortar? Assume necessary data if any required. [12]
5. a) Describe types of bond use in masonry construction. How does strength of masonry unit and grade of mortar affect the capacity of a masonry? [4+4]
- b) Describe in plane and out plane behavior of masonry structure with sketches. How do you improve the seismicity performance of the structure? Draw the elements that resist lateral loads in masonry wall in load bearing building? [2+2+4]

\*\*\*

Exam.	Back		
Level	BE	Full Marks	80
Programme	BCE	Pass Marks	32
Year / Part	III / I	Time	3 hrs.

**Subject: - Concrete Technology and Masonry Structure (CE 603)**

- ✓ Candidates are required to give their answers in their own words as far as practicable.
- ✓ Attempt All questions.
- ✓ The figures in the margin indicate Full Marks.
- ✓ If any Allowed codes / Necessary chart specify IS code 1905-1987.
- ✓ Assume suitable data if necessary.

1. a) State briefly four mechanical properties of aggregate. Explain bulking of sand. [4+2]
- b) Describe concrete as three phase system and explain the structure of hcp in concrete. [6]
2. a) Design a concrete mix using ACI method. The specified strength of concrete is 25MPa at 28 days. The specific gravity of FA and CA are 2.6 and 2.7 respectively. Use standard deviation as 4 MPa. The dry rodded bulk density of CA is 1650 kg/m<sup>3</sup> and fineness modulus of FA is 2.8. Approximate air entrapped is 2%. Assume suitable data if required. [8]
- b) How would you maintain the quality control in site? [4]
3. a) Explain Maturity of concrete. Define shrinkage and creep of concrete. [6]
- b) Explain chemical causes of concrete deterioration. [6]
4. a) Explain Rebound Hammer test and Ultrasonic Pulse Velocity test. [6]
- b) Calculate the splitting tensile strength of concrete cylinder (300mm × 150mm dia) an cube (150mm×150mm×150mm) under standard splitting test, if the load shows by testing machine is 500KN. [6]
5. a) What are the uses of masonry structures? Explain with neat sketches. [6]
- b) Explain the in-plane and out-of-plane behaviour of masonry structures. [6]
6. a) Design an interior cross wall of a three storied building to carry 150mm thick RCC slab with ceiling height of 3.5m. [12]

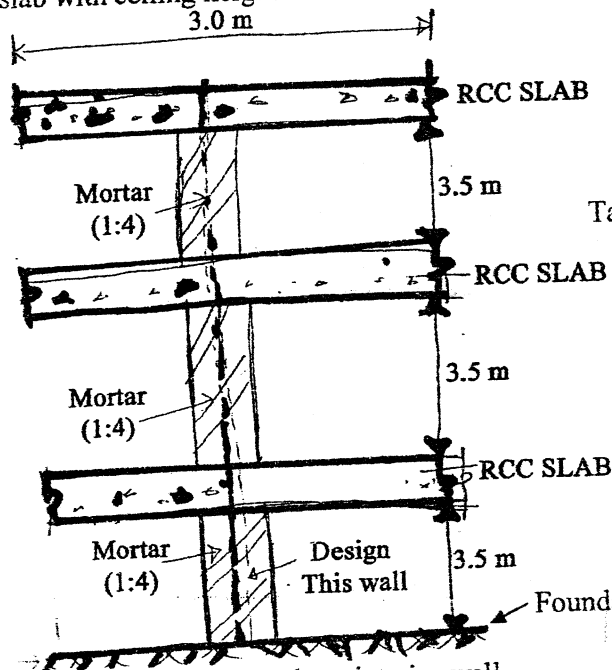

Take Live load on roof = 2 KN/m<sup>2</sup>  
Live load on floors = 3.5 KN/m<sup>2</sup>  
Floor finishes = 1.5 KN/m<sup>2</sup>

Figure: Cross Section along interior wall

- b) A column section 400mm × 800 mm carries load 250 KN acting at 160mm from the 800 mm face and 350 mm from the 400 mm face. Determine the stress intensities at all four corners. [8]

TRIBHUVAN UNIVERSITY  
INSTITUTE OF ENGINEERING  
**Examination Control Division**  
2075 Chaitra

Exam.	Regular / Back		
	Level	BE	Full Marks
Programme	BCE	Pass Marks	32
Year / Part	III / I	Time	3 hrs.

**Subject: - Concrete Technology and Masonry Structure (CE 603)**

- ✓ Candidates are required to give their answers in their own words as far as practicable.
- ✓ Attempt All questions.
- ✓ The figures in the margin indicate Full Marks.
- ✓ Necessary charts are attached herewith.
- ✓ IS 1905:1987 is allowed code.
- ✓ Assume suitable data if necessary.

1. a) Define structural concrete. List out the different types of concrete used in civil engineering construction. [2+4]
- b) Explain concrete as three phase system. Explain in brief, the transition zone effect in concrete properties. [4+2]
2. a) Define the concrete mix design of concrete. Describe the steps of Design mix of concrete by DOE method. [2+6]
- b) Explain quality control in site in different phase of construction. [4]
3. a) Describe the various strength tests on cement concrete. [6]
- b) Describe the elastic properties and the Modulus of elasticity of concrete. [6]
4. a) Explain the non-destructive testing technique on concrete works. [6]
- b) Explain physical causes of concrete deterioration. [6]
5. a) What are the main elements that resist the lateral load? Explain with sketches. [6]
- b) Explain with neat sketches, Flat-jack test and push-shear test. [3+3]
6. a) A wall 230mm thick, using modular bricks carries at the top a load of 100kN/m having resultant eccentricity ratio of 1/12. Wall is 5m long between cross walls and is 3.5m clear height between RCC slabs at the top and bottom. What shall be the strength of brick and the grade of mortar? Assume that joints are not raked. [12]
- b) Column section 500mm x 900mm carries a load 300 kN acting at 170 mm from the 900 mm face and 360 mm from the 500 mm face. Determine the stresses intensities at all four corners. [8]

\*\*\*

Compressive strength at 28 days, MPa*	Water-cement ratio, by mass	
	Non-air-entrained concrete	Air-entrained concrete
40	0.42	0.39
35	0.47	0.45
30	0.54	0.61
25	0.61	0.69
20	0.69	0.70
15	0.79	

Water, Kg/m<sup>3</sup> of concrete for indicated nominal maximum sizes of aggregate

Slump, mm	Non-air-entrained concrete									
	9.5*	12.5*	19*	25*	37.5*	50†*	75††	150†††		
25 to 50	207	199	160	178	166	154	130	113		
75 to 100	228	216	205	192	181	169	145	124		
150 to 175	243	228	216	202	190	178	160	—		
Approximate amount of entrapped air in non-air-entrained concrete, percent	3	2.5	2	1.5	1	0.5	0.3	0.2		

Air-entrained concrete

25 to 50	181	175	168	160	159	142	122	107
75 to 100	202	193	184	175	165	157	133	119
150 to 175	216	205	197	184	174	166	154	—
Recommended average total air content, percent for level of exposure:								
Mild exposure	4.5	4.0	3.5	3.0	2.5	2.0	1.5**††	1.0**††
Moderate exposure	6.0	5.5	5.0	4.5	4.5	4.0	3.5**†††	3.0**†††
Extreme exposure††	7.5	7.0	6.0	6.0	5.5	5.0	4.5**†††	4.0**†††

Types of construction	Slump, mm		Nominal maximum size of aggregate, mm	Volume of dry-rodded coarse aggregate per unit volume of concrete for different fineness moduli† of fine aggregate				
	Maximum*	Minimum		2.40	2.60	2.80	3.00	
Reinforced foundation walls and footings	75	35	9.5	0.50	0.48	0.45	0.44	
Plain footings, caissons, and substructure walls	75	25	12.5	0.59	0.57	0.55	0.53	
Beams and reinforced walls	109	25	19	0.66	0.64	0.62	0.60	
Building columns	160	25	25	0.71	0.69	0.67	0.65	
Pavements and slabs	75	25	37.5	0.75	0.73	0.71	0.69	
Mass concrete	75	25	50	0.78	0.76	0.74	0.72	
			75	0.82	0.80	0.78	0.76	
			150	0.87	0.85	0.83	0.81	



Exam.	Back		
	Level	BE	Full Marks
Programme	BCE	Pass Marks	32
Year / Part	III / I	Time	3 hrs.

**Subject: - Concrete Technology and Masonry Structure (CE603)**

- ✓ Candidates are required to give their answers in their own words as far as practicable.
- ✓ Attempt **All** questions.
- ✓ The figures in the margin indicate **Full Marks**.
- ✓ **IS Code 1905-1987 is allowed.**
- ✓ Assume suitable data if necessary.

1. a) Explain the basic requirement of coarse and fine aggregates in concrete which is to be used in construction field. Why need to grading of aggregate? [4+2]
  - b) Describe concrete as three phase system and also explain the effects of hcp structure in the concrete properties. [2+4]
  - c) Define workability. List the factors that affect the workability of the concrete. [1+2]
2. a) What is the nominal mix of concrete design? How it is used in field? [3+2]
  - b) What are the key concepts of ACI method of concrete mix proportioning? Explain with suitable example. [8]
3. a) Explain how height/diameter ratio of cylindrical test specimen affect the relative compressive strength of concrete? How can you determine tensile strength of concrete using splitting tension test method, Explain in brief? [2+4]
  - b) Write about physical and chemical causes of concrete deterioration. What are the effects of corrosion of steel in concrete? [4+3]
4. a) What is the use of non-destructive test (NDT) on civil engineering field? List out the non-destructive test methods in brief. [2+4]
  - b) Describe the mechanical and physical causes of concrete deterioration. [4+3]
5. a) Explain the importance of masonry structure as load bearing element in context of Nepal. [3]
  - b) Design an interior cross wall of two storeyed building to carry 120 mm thick RCC slab with ceiling height of 3.0m. The wall is unstiffened and supports a 2.5m wide slab on both sides. Assume suitable data if required,
 

Live Load on roof =  $1.50 \text{ KN/m}^2$   
 Live Load on Floor =  $2.0 \text{ KN/m}^2$   
 Wt. of 60mm screed including finishing =  $1.2 \text{ KN/m}^2$  [10]
6. a) What are the in-plane and out-of-plane behavior of masonry structures? Describe in detail with necessary sketches. [3+3]
  - b) List out the non-destructive testing technique on brick masonry wall. [3]
  - c) Explain with neat sketches, Elastic wave tomography test and push shear test for masonry structures. [2+2]



Exam.	Back		
Level	BE	Full Marks	80
Programme	BCE	Pass Marks	32
Year / Part	III / I	Time	3 hrs.

**Subject: - Concrete Technology and Masonry Structure (CE603)**

- ✓ Candidates are required to give their answers in their own words as far as practicable.
- ✓ Attempt All questions.
- ✓ The figures in the margin indicate Full Marks.
- ✓ Assume suitable data if necessary.
- ✓ Use of IS: 1905-1987 is allowed to design Masonry Structure.

1. a) Explain in brief about Bogue's compound of cement. List the types of admixtures used in concreting works and explain the purpose of using admixtures. [2+2+2]  
 b) What do you understand by transition phase of concrete? Explain the effect of transition phase in the properties of concrete. [3+3]
2. a) Explain ACI method of concrete mix design. [8]  
 b) Define workability and Write down the procedure for performing slump test. [1+3]
3. a) Explain elastic deformation, shrinkage and creep in concrete. [2+2+2]  
 b) Explain methods for performing flexural test of concrete. [6]  
 c) How is Ultrasonic Pulse Velocity test carried out? How do you interpret the results obtained from the test with the quality of concrete? [4+2]
4. a) Describe chemical causes of concrete deterioration. [6]  
 b) What do you understand by masonry structure? State its structural limitations. Explain English and Flemish bond. [2+4]
5. A brick wall 23 cm thick using modular brick carried eccentric load of 165 KN/m at base (eccentricity ratio at 1/12). The wall is 4.5 m long between cross walls. The clear height of wall is 3.1 m between RCC slabs of 10 cm thick at top and bottom. What should be the strength of brick and Grade of mortar? Assume that joints are not raked. [12]
6. a) Describe In-plane and out of plane behaviour of masonry structure. What are the elements that resist lateral loads in masonry system. [6+2]  
 b) Explain Compressive and Diagonal Shear Tests in masonry structures? [3+3]

\*\*\*

Exam.	Regular		
	Level	BE	Full Marks
Programme	BCE	Pass Marks	32
Year / Part	III / I	Time	3 hrs.

**Subject: - Concrete Technology and Masonry Structure (CE603)**

- ✓ Candidates are required to give their answers in their own words as far as practicable.
- ✓ Attempt **All** questions.
- ✓ The figures in the margin indicate **Full Marks**.
- ✓ **IS Code 1905-1987 is allowed.**
- ✓ Assume suitable data if necessary.

1. a) What is soundness of aggregates? How it is measured in Laboratory? [2+3]
- b) Explain the concrete as three phase system with necessary sketches. Describe the structure of the hcp phase. [3+2]
- c) Describe the different types of admixtures used in concreting works at site. [5]
2. a) Describe stepwise procedure for ix design of concrete by DOE method. [7]
- b) Explain properties of hardened concrete. [6]
3. a) What is work ability of concrete? Describe in details different methods to measure work ability of concrete during concreting work at construction site. [2+3]
- b) Explain the maturity of concrete with suitable example. [4]
- c) What are the destructive tests (DT) of concrete? [4]
4. a) Describe the importance of Non-destructive testing of concrete. Explain Schmidt hammer test. [3+4]
- b) Explain the physical causes of concrete deterioration. [6]
5. a) Design an interior cross-wall of a two - storeyed building to carry 130 mm thick RCC slab with ceiling height of 2.8 m and the wall is 3.2 m long which is stiffened and supports 2m slab on both sides as shown in figure below. [9]

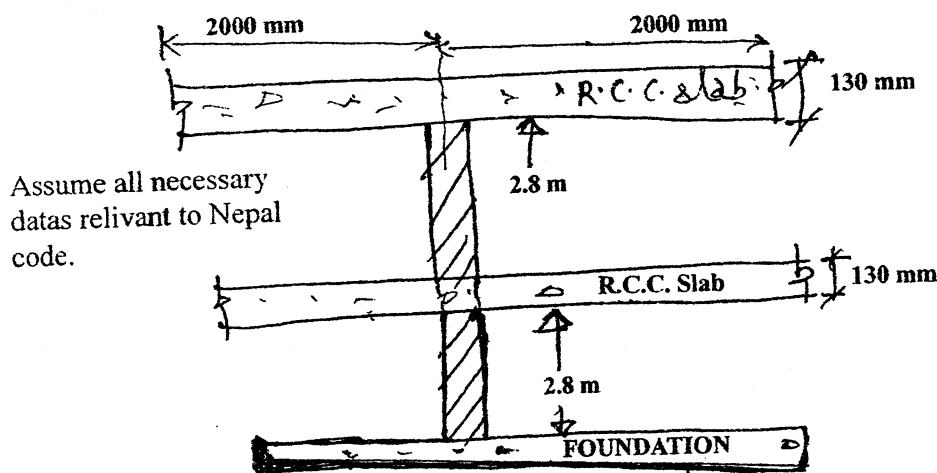

- b) Describe the role of brick masonry infill walls with neat sketches. [4]
6. a) Describe the In-plane and Out of Plane behavior of masonry structures. Explain ductile behavior of reinforced and unreinforced masonry structure. [2+4]
- b) List the elements of masonry structure resisting lateral loads. Describe the stepwise procedure for Diagonal shear test of Masonry structure. [2+5]

Exam.	New Back (2066 & Later Batch)		
Level	BE	Full Marks	80
Programme	BCE	Pass Marks	32
Year / Part	III / I	Time	3 hrs.

**Subject: - Concrete Technology and Masonry Structure (CE603)**

- ✓ Candidates are required to give their answers in their own words as far as practicable.
- ✓ Attempt **All** questions.
- ✓ The figures in the margin indicate **Full Marks**.
- ✓ Assume suitable data if necessary.

1. a) Define mechanical properties of aggregate. How do you rank the aggregate grading in lab? [4]
- b) Explain concrete as three phase materials and describe transition zone in detail. [6]
- c) Describe creep and shrinkage phenomenon for hardened concrete. [6]
2. a) How do you assure the quality control of concrete at site? Explain slump test in detail. [6]
- b) Differentiate Nominal and design mix. Describe the stepwise process of mix-design of concrete by ACI method. [2+8]
3. a) What is modulus of rupture of concrete? How do you determine it in laboratory? [2+4]
- b) Describe the importance of non-destructive tests in concrete and its uses in civil engineering infrastructures. [6]
- c) What are the standard process adopted on each process of concrete production. [4]
4. a) Explain the use of different types of closer in brick masonry works. Describe the key points of English bond and Flemish bond. [6]
- b) Design an interior Cross wall of a two-storeyed building to carry 125 mm thick RCC slab with 3.2 m ceiling height. The wall is unstiffened and supports a 2.5 m wide slab on both sides. [10]
 

Live load on roof = 1.5 KN/m<sup>2</sup>  
 Live load on floor = 2.0 KN/m<sup>2</sup>  
 Floor finishing = 1.2 KN/m<sup>2</sup>
5. a) A column section 400 mm × 800 mm carries load 250 kN acting at 160 mm from the 800 mm face and 350 mm from the 400 mm face. Determine the stress intensities at all four corners. [10]
- b) Describe the diagonal shear test for masonry wall. [6]

\*\*\*

Exam.	Regular		
	Level	BE	Full Marks
Programme	BCE	Pass Marks	32
Year / Part	III / I	Time	3 hrs.

**Subject: - Concrete Technology and Masonry Structure (CE603)**

- ✓ Candidates are required to give their answers in their own words as far as practicable.
- ✓ Attempt All questions.
- ✓ The figures in the margin indicate Full Marks.
- ✓ Assume suitable data if necessary.
- ✓ Use of IS: 1905-1987 is allowed to design Masonry Structure.

1. a) State briefly the mechanical properties of aggregate. What is the meaning of fineness modulus of aggregate value 7? [5+1]
- b) Describe concrete as three phase system. Explain the effect of transition zone in the properties of concrete. [4+2]
2. What do you mean by shrinkage, creep, segregation and bleeding in concrete? Write down the step-wise process for DoE method of concrete mix design. [6+6]
3. a) How does the size of aggregate affect the strength of concrete? How does variation in water cement ratio affect the property of concrete? [3+3]
- b) List out the non-destructive testing of concrete. How these methods are useful? [3+3]
- c) Explain the methods of testing concrete for compressive and flexural strength. [4+2]
4. a) Describe physical causes of concrete deterioration. [6]
- b) Explain various types of Brick bonds in masonry structures with neat sketches. What are the advantages and disadvantages of Rat Trap Bond. [4+2]
5. Referring to figure below, design an interior cross wall of 3 storeyed building to carry 125 mm thick RCC slab with ceiling height of 3 m and the wall is 3 m long which is stiffened and supports 3 m slab on both sides, [12]

Live Load on roof = 2 KN/m<sup>2</sup>

Live Load on floor = 2.5 KN/m<sup>2</sup>

Floor Finish = 1.5 KN/m<sup>2</sup>

Assume relevant necessary data.

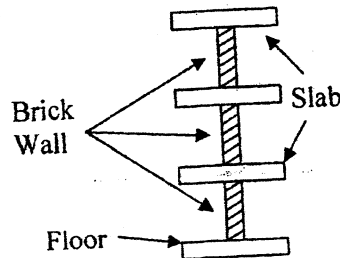

6. a) Describe the elements of lateral load resisting masonry system with sketch. Elaborate the typical damages in masonry structure under lateral loads. [4+4]
- b) Describe with sketches, the diagonal shear test and flat jack test. [6]

\*\*\*

Exam.	New Back (2066 & Later Batch)		
Level	BE	Full Marks	80
Programme	BCE	Pass Marks	32
Year / Part	III / I	Time	3 hrs.

**Subject: - Concrete Technology and Masonry Structure (CE603)**

- ✓ Candidates are required to give their answers in their own words as far as practicable.
- ✓ Attempt All questions.
- ✓ The figures in the margin indicate Full Marks.
- ✓ Assume suitable data if necessary.
- ✓ Code IS 1905-1987 is allowed.

1. a) Describe Mechanical properties of Aggregates. [6]  
b) Explain concrete as three phase system and explain Binding medium phase in detail. [6]
2. a) Design the mix proportion for concrete with help of the following particulars using IS method: [8]  
Design parameters:  
Characteristic strength  $f_{ck} = 30 \text{ N/mm}^2$   
Max size of aggregate = 20 mm  
Shape of CA = Angular  
Degree of workability = 0.85  
Degree of quality control = Fair  
Degree of exposure = Severe  
(Assume all necessary relevant data)  
b) How do you assure the quality control of concrete at site? [4]  
c) Describe creep and shrinkage phenomenon for hardened concrete. [6]
3. a) How do you determine modulus of rupture of concrete specimen in Lap? Explain. [6]  
b) Explain non-destructive testing process of concrete and explain its importance. [6]  
c) What are the effects of carbonation and permeability on concrete durability? [6]
4. a) Explain the use of Masonry structure. Describe the types of bond of brick masonry with neat sketches. [6]  
b) A wall 230 mm thick, using modular bricks carries at the top a load of 100 kN/m having resultant eccentricity ratio of 1/12. Wall is 5 m long between cross walls and is 3.5 m clear height between RCC slabs at the top and bottom. What shall be the strength of brick and the grade of mortar? [12]
5. a) Explain design process for a masonry wall under lateral loadings. [8]  
b) Describe the diagonal shear test for masonry wall. [6]

\*\*\*

Exam.	Regular		
Level	BE	Full Marks	80
Programme	BCE	Pass Marks	32
Year / Part	III / 1	Time	3 hrs.

**Subject: - Concrete Technology and Masonry Structure (CE603)**

- ✓ Candidates are required to give their answers in their own words as far as practicable.
- ✓ Attempt **All** questions.
- ✓ The figures in the margin indicate **Full Marks**.
- ✓ Assume suitable data if necessary.

1. a) Define grade of cement. Explain the role of Bouge's compound of cement. [4]
- b) List out common admixture available in market. Elaborate in brief the accelerating admixture. [6]
- c) Explain the three phases of concrete and their role in concrete strength. [6]
2. a) Design the mix proportion for concrete with help of the following given datas: [10]
 

Design parameters:

Concrete grade: M 25

Max size of aggregate: 25 mm

Specific gravity of C.A: 2.7

Specific gravity of F.A: 2.6

Degree of expose: Moderate

Fineness modulus of F.A: 3.00

Method of design: DOE method

Based on obtained your mix ratio, calculate the quantity of ingredients of concrete for 2 m<sup>3</sup> concrete production. (Assume all necessary relevant datas)
- b) Describe the elastic properties of concrete. [6]
3. a) Why non-destructive test is important in concrete structures and list out the NDT methods. [6]
- b) Explain in brief chemical causes of concrete deterioration. [4]
- c) Explain fatigue and impact strength of concrete. [6]
4. a) Define the Reinforced and unreinforced masonry structure. Explain with neat sketch Rat-trap bond and mention its advantages. [6]
- b) A wall 230 mm thick, using modular bricks carries at the top a load of 100 kN/m having resultant eccentricity ratio of 1/12. Wall is 5 m long between cross walls and is 3.5 m clear height between RCC slabs at the top and bottom. What shall be the strength of brick and the grade of mortar? Assume that joints are not ranked. [10]
5. a) Explain the effect of lateral loads on masonry wall with and without opening in wall. [6]
- b) Describe the diagonal shear test for wall. [6]
- c) List the name of destructive tests and non-destructive (NDT) tests in masonry wall. [4]



Exam.	New Back (2066 & Later Batch)		
Level	BE	Full Marks	80
Programme	BCE	Pass Marks	32
Year / Part	III / I	Time	3 hrs.

**Subject: - Concrete Technology and Masonry Structure (CE603)**

- ✓ Candidates are required to give their answers in their own words as far as practicable.
- ✓ Attempt All questions.
- ✓ The figures in the margin indicate Full Marks.
- ✓ Assume suitable data if necessary.

1. a) Define admixtures. What is the role of admixtures in concrete? Explain the use of superplasticizer in concrete. [2+4]
- b) Explain in details the necessity of three phase system of concrete. [6]
- c) What do you understand by workability of concrete? How do you measure the workability of concrete? [4]
2. a) Describe the conceptual steps of concrete mix design based on IS method. [4]
- b) Explain the types of slumps. How you measure slumps in concretes. [4]
- c) Calculate the gel/space ratio and the theoretical strength of a sample concrete made with 600 gm of cement with 0.45 water/cement ratio, on full hydration and at 60 percentage hydration. [4]
- d) What is fatigue effect in concrete? [2]
3. a) Explain the importance of Non-destructing testing of concrete in civil engineering structures. [6]
- b) How do you determine the compressive strength of concrete using Ultrasonic pulse Velocity method? [6]
- c) What are the physical and chemical causes of concrete deterioration? [6]
4. a) Explain with neat sketches English bond and Flemish bond of brick masonry work. [6]
- b) A wall 230mm thick, using modular bricks carries at the top a load of 100kN/m having resultant eccentricity ratio of 1/12. Wall is 5m long between cross walls and is 3.5 m clear height between RCC slabs at the top and bottom. What shall be the strength of brick and the grade of mortar? [12]
5. a) Describe about compression test and diagonal shear test of masonry wall. What is the basic difference between these two tests? [6]
- b) Describe in details with necessary sketches in plane and out of plane behavior of masonry structures. [8]

06

TRIBHUVAN UNIVERSITY

INSTITUTE OF ENGINEERING

Examination Control Division

2071 Chaitra

Exam.	Regular		
Level	BE	Full Marks	80
Programme	BCE	Pass Marks	32
Year / Part	III / I	Time	3 hrs.

**Subject: - Concrete Technology and Masonry Structure (CE603)**

- ✓ Candidates are required to give their answers in their own words as far as practicable.
- ✓ Attempt All questions.
- ✓ The figures in the margin indicate Full Marks.
- ✓ Assume suitable data if necessary.
- ✓ Code IS 1905-1987 is allowed.

1. a) Explain concrete ingredients and concrete as structural materials over steel. [6]
- b) Describe concrete as three phase system and explain the effects of Transition zone in the properties of concrete. [6]
2. a) Describe the stepwise process of the mix design of concrete by DOE method. [8]
- b) What are the effects of hot weather on concreting and also explain the precautionary measures to take for concreting in hot weather? [4]
- c) Explain effect of gel/space ratio in theoretical strength of concrete. [6]
3. a) Explain tests to estimate strength of concrete in compression and tension. [6]
- b) What is the importance of Non-destructive tests for concrete structure? Explain. [6]
- c) Explain the physical and chemical causes of concrete deterioration. List out effect of corrosion of steel in concrete. [6]
4. a) Design an exterior wall of a single storey warehouse of 3.5 m height. The loading on the wall consists of vertical load of 25 KN/m from the roof and wind pressure of 860 N/m<sup>2</sup>. The wall is tied with metal anchor at the floor and roof level. [12]
- b) A column section 400 mm × 800 mm carries load 250 kN acting at 160 mm from the 800 mm face and 350 mm from the 400 mm face. Determine the stress intensities at all four corners. [8]
5. a) Explain use of masonry structures as load bearing and non-load bearing walls. [6]
- b) Describe the flat jack test for brick masonry wall with neat sketch set up. [6]

\*\*\*

04 TRIBHUVAN UNIVERSITY INSTITUTE OF ENGINEERING Examination Control Division 2070 Chaitra	Exam.	Regular	
	Level	BE	Full Marks 80
	Programme	BCE	Pass Marks 32
	Year / Part	III / I	Time 3 hrs.

**Subject: - Concrete Technology and Masonry Structure (CE603)**

- ✓ Candidates are required to give their answers in their own words as far as practicable.
- ✓ Attempt All questions.
- ✓ The figures in the margin indicate Full Marks.
- ✓ Assume suitable data if necessary.

1. a) What are the ingredients of olden age concrete and modern age concrete? Explain use of concrete as structural materials. [4]
- b) What are the effects of the shape and texture of aggregates on the strength and workability of concrete? [2]
- c) Describe concrete as three phase system and explain the effects of Transition zone in the properties of concrete. [6]
2. a) Design the mix proportion for concrete with the help of following particulars using American Concrete Institute (ACI) method: [8]
  - Characteristics compressive strength,  $f_{ck} = 30 \text{ Mpa}$
  - Water cement ratio based on the compressive strength = 0.48
  - Assume all necessary data.
- b) What are the effects of cold weather concreting and also explain the precautionary measures to take for concreting in cold weather? [4]
- c) What is the young's modulus of elasticity of concrete? [3]
- d) Describe shortly the creep and shrinkage. [2]
3. a) Describe in details, tensile strength tests of concrete. [3]
- b) Calculate the modulus of rupture of the concrete beam under single and two point loading for following data: Size of beam = 150mm×150mm, length of beam = 750 mm. Failure loads for single point loading is 100KN and two point loadings each of 50KN. [4]
- c) Explain, in brief, physical and chemical causes of concrete deterioration. [6]
- d) Write down the acceptance criteria of compressive and flexural strength according to IS456-2000. [4]
4. a) Explain the use of Masonry structure. Describe the types of bond of brick masonry with neat sketches. [6]
- b) Design an interior cross wall of a two storeyed building to carry 120 mm thick RCC slab with 3.0 m ceiling height. The wall is unstiffened and supports a 3.0 m wide slab on both sides. Assume necessary data relevant to Nepal. [10]
  - Live load on roof =  $2 \text{ KN/m}^2$
  - Live load on floor =  $2.5 \text{ KN/m}^2$
  - Floor finishing =  $1.5 \text{ KN/m}^2$

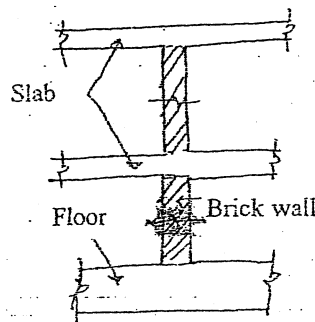

5. a) Explain about the typical damage in masonry structure under lateral loads. [4]
- b) A column section  $400 \text{ mm} \times 800 \text{ mm}$  carries a load  $200 \text{ kN}$  acting at  $160 \text{ mm}$  from the  $800 \text{ mm}$  face and  $350 \text{ mm}$  from the  $400 \text{ mm}$  face. Determine the stress intensities at all four corners. [8]
- c) Describe the diagonal shear test for masonry wall. [6]

\*\*\*

01 TRIBHUVAN UNIVERSITY  
 INSTITUTE OF ENGINEERING  
 Examination Control Division  
 2070 Ashad

Exam.	Old Back (2065 & Earlier Batch)		
Level	BE	Full Marks	40
Programme	BCE	Pass Marks	16
Year / Part	III / I	Time	1½ hrs.

*Subject: - Concrete Technology (EG633CE)*

- ✓ Candidates are required to give their answers in their own words as far as practicable.
- ✓ Attempt any Four questions.
- ✓ The figures in the margin indicate Full Marks.
- ✓ Assume suitable data if necessary.

1. a) Define soundness and Abrasion strength. [5]
- b) Find the mean strength, standard deviation, and coefficient of variation of the cubes given in table: [5]

Cubes	1	2	3	4	5	6
Strength (N/mm <sup>2</sup> )	170	200	190	160	180	195

2. a) Explain the phenomenon of corrosion in steel reinforcement in RCC. Discuss the preventive measures against corrosion of steel in RCC structures. [5]
- b) Explain about Elastic and Plastic properties of concrete. [5]
3. a) 'Ordinary Portland Cement' is admirably suitable for general concrete construction work. Justify the statement with reference to Bogue's equation. [5]
- b) Explain briefly about the differences between accelerating admixtures and retarding admixtures. [5]
4. a) Differentiate between the nominal mix and design mix concrete. List out the information required for mix design of concrete. [5]
- b) Explain in brief the role of water/cement ratio in concrete and methods of decreasing this ratio. What is super plasticizer? Write three benefits of using super plasticizer in the concrete. [5]
5. Write short notes on: (any four) [4×2.5]
- a) Physical Properties of concrete
  - b) Steam curing of concrete
  - c) Bond between steel and concrete
  - d) Flakiness index of aggregate
  - e) Shear strength

\*\*\*

Exam.	Regular		
Level	BE	Full Marks	80
Programme	BCE	Pass Marks	32
Year / Part	III / I	Time	3 hrs.

**Subject:** - Concrete Technology and Masonry Structure (CE603)

- ✓ Candidates are required to give their answers in their own words as far as practicable.
- ✓ Attempt All questions.
- ✓ The figures in the margin indicate Full Marks.
- ✓ Assume suitable data if necessary.

1. a) How can the shape of aggregate affect the properties of hardened concrete? How does the grading of aggregate affect the water requirement of the mix? Also explain the effects of Alkali-Aggregate reaction. [2+2+1]
- b) Describe the role of main compounds of cement on development of strength. [3]
- c) List the admixture used in concrete. [2]
- d) Describe concrete as three phase system. Explain the effect of transition zone in the properties of concrete. [6]
2. a) How can you determine the workability of concrete using different methods at civil engineering construction site? [6]
- b) What are the key concepts of Mix-design of concrete by using DOE method of mix-design? [6]
- c) Describe shrinkage and creep of concrete. [4]
3. a) Explain the electrochemical process of corrosion in reinforced concrete elements. How does the corrosion affect the concrete element? Explain with sketches. [6]
- b) Describe various strength of concretes required for design of concrete structures along with their relation with the compressive strength [6]
- c) Explain the measures for quality control of concrete in a construction site. [4]
4. a) External wall of a single storeyed house is 230 mm thick and has door and window openings as shown in figure below. Plinth level is 1500mm above the top of foundation footing and floor ceiling height is 2800 mm. The one way R.C.C slab of 3500 mm clear span bears on walls and is 115 mm thick. Determine the maximum stress in the wall and calculate strength of the bricks and grade of mortar required for the wall. [10]

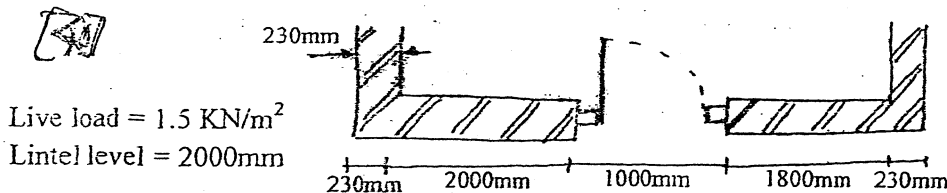

- b) How do you test the compressive strength of bricks and walls in laboratory? [6]
5. a) Explain the use of Masonry structures in civil engineering. Describe English bond and flemish bond of brick masonry with neat sketches. [2+4]
- b) A brick masonry wall of a single room building is 20 cm thick and is supported by 10 cm thick R.C.C slab at its top and bottom. The wall carries a vertical load (inclusive of its own weight) of 8000 Kg/m at the base at an eccentricity ratio of 0.1. The length of wall is 3 m between cross-walls. The clear height of storey is 3m. Determine the required crushing strength of bricks and the type of mortar to be used. Use modular bricks. [10]

**TRIBHUVAN UNIVERSITY**  
**INSTITUTE OF ENGINEERING**  
**Examination Control Division**  
**2079 Bhadra**

Exam. Level	Regular		
	BE	Full Marks	80
Programme	BCE	Pass Marks	32
Year / Part	III / I	Time	3 hrs.

**Subject: - Engineering Hydrology (CE 606)**

- ✓ Candidates are required to give their answers in their own words as far as practicable.
- ✓ Attempt **All** questions.
- ✓ The figures in the margin indicate **Full Marks**.
- ✓ Assume suitable data if necessary.

1. Discuss water balance and water budget analysis in hydrology. [4]
2. a) A catchment has six rain gauge stations. In a year, the annual rainfall in cm recorded by the gauges are as follows: 240, 252.2, 228.3, 218.6, 275.3, 212.2. For a 10% error in the estimation of the mean rainfall, calculate the optimum number of stations in the catchment. [4]
- b) Explain briefly the following relationships relating to the precipitation over a basin. (i) Depth-Area Duration Curves (ii) Intensity-Duration Frequency Relationship. [3+3]
3. a) What are the advantages of double ring infiltrometer over single ring infiltrometer. [4]
- b) Determine  $\phi$ -index for a watershed with catchment area of 0.8 km<sup>2</sup> if temporal distribution of rainfall at different time duration are as the following table. Take surface runoff as 92,800 m<sup>3</sup>. [6]

Duration (hr)	1	2	3	4	5	6	7	8
Incremental rainfall (cm)	0.8	1.8	3.0	4.6	3.6	3.2	2.0	1.0

4. a) Write about the methods practiced in Nepal for estimating runoff from ungauged basins. [4]
- b) The following data is observed on a stream using current meter. The rating equation of current meter is  $V = (0.05 + 0.3N)$  m/s, where N is rev/sec was used to measured the velocity at 0.6 d depth. Calculate the discharge of the stream. [8]

Distance from bank (m)	0.8	1.6	2.4	3.0	3.6	4.2	5.0	5.8	6.6
Depth (m)	0.5	1.0	1.6	2.0	2.0	1.8	1.2	0.6	0.0
No. of rev.	12	23	27	33	32	28	24	14	-
Time (sec)	48	52	54	58	58	53	50	45	-

5. a) The ordinates of 6-h UH of a basin are given as under.

Time h	0	6	12	18	24	30	36	42	48
Ordinates m <sup>3</sup> /s	0	6	12	25	10	8	6	3	0

Derive the storm hydrograph due to a 3-h storm with a total rainfall of 15 cm. Assume initial loss of 0.50 cm and  $\Phi$ -index of 1 cm/h. Take base flow of 4 m<sup>3</sup>/s. [8]

- b) Explain the concept of the unit hydrograph. What are the assumptions and limitations of unit hydrograph theory? [2+4]

6. a) Analysis of the annual flood peak data of a certain river covering the period of 25 years has the mean of 8520 and standard deviation of 3900 m<sup>3</sup>/s. The proposed water control project near this site has an expected life of 45 years. The policy decision for project provides the reliability of 85%. [4+2]

(i) Using Gumbel's method recommend peak discharge. Take  $y_n = 0.5309$  and  $S_n = 1.0915$

(ii) Calculate the design discharge if factor of safety is 1.3 and also the corresponding safety margin.

- b) A rainfall storm for the duration of 20 mins, 40 mins and 80 mins are 40 mm, 70 mm, 90 mm and 100 mm respectively. If the slope of the catchment is 0.01, runoff coefficient is 0.7, maximum length of the travel is 1,100 m and catchment area is 3 km<sup>2</sup>, estimate the peak flow by rational method. [6]

7. a) Explain briefly the basic principles involved in the development of IUH by Clark's method. [6]

- b) A drainage basin has area of 157 km<sup>2</sup>, storage constant = 8h and time of concentration = 7h has the following inter isochrone area distribution data.

Time h	0-1	1-2	2-3	3-4	4-5	5-6	6-7
Inter isochrone area km <sup>2</sup>	10	38	20	45	32	10	2

Route the flood hydrograph. [6]

- c) Why flow routing is required? Explain Time-Area method of Routing. [6]

\*\*\*



TRIBHUVAN UNIVERSITY  
INSTITUTE OF ENGINEERING  
**Examination Control Division**  
2079 Baishakh

Exam.	Back		
Level	BE	Full Marks	80
Programme	BCE	Pass Marks	32
Year / Part	III / 1	Time	3 hrs.

**Subject: - Engineering Hydrology (CE 606)**

- ✓ Candidates are required to give their answers in their own words as far as practicable.
- ✓ Attempt **All** questions.
- ✓ The figures in the margin indicate **Full Marks**.
- ✓ Assume suitable data if necessary.

1. Discuss signification of hydrology in civil engineering application with appropriate examples. [4]
2. a) Explain about IDF curve and DAD curve. [2+2]
- b) The annual rainfall at station X and the average annual rainfall at 18 surrounding stations are given below. Check the consistency of the record at station X and determine the year in which a change in regime has occurred. Determine the average annual rainfall for the period 1952-1970 for the changed regime. [8]

Year	Annual rainfall (cm)	
	Station. X	18-stations' average
1952	30.5	22.8
1953	38.9	35
1954	43.7	30.2
1955	32.2	27.4
1956	27.4	25.2
1957	32	28.2
1958	49.3	36.1
1959	28.4	18.4
1960	24.6	25.1
1961	21.8	23.6
1962	28.2	33.3
1963	17.3	23.4
1964	22.3	36
1965	28.4	31.2
1966	24.1	23.1
1967	26.9	23.4
1968	20.6	23.1
1969	29.5	33.2
1970	28.4	26.4

3. a) Briefly explain the importance of solar radiation, relative humidity, evapotranspiration in relation to the hydrologic cycle. [2+2+2]
- b) For the following rainfall-runoff data, determine the  $\phi$ -index and ordinates of cumulative infiltration curve based upon the  $\phi$ -index. The watershed area is  $0.2 \text{ km}^2$ : [6]

Time (h)	1	2	3	4	5	6	7
Rainfall rate (cm/hr)	1.05	1.28	0.80	0.75	0.70	0.60	0
Direct Runoff ( $\text{m}^3/\text{s}$ )	0	30	60	45	30	15	0

- c) Describe the procedure of calculating evapotranspiration by Penman's method. [5]

4. a) How rating curves are developed? Also discuss permanent and shifting controls with appropriate illustrations/figures. [3+3]

- b) A current meter (rating equation:  $V: (0.53N+0.05)$  m/s, where  $N$  = revolutions per second) was used to measure the velocity at 0.6 depth. If current meter readings at various locations at a cross sections are as in the following table, calculate the discharge in the stream. [8]

Distance from right bank (m)	0	1	3	5	7	9	11	12
Depth (m)	0	1.2	2.1	2.6	2.0	1.7	1.1	0.0
No of revolutions	0	39	58	112	90	45	30	0
Time (seconds)	0	100	100	150	100	100	100	0

5. a) How the base flow can be separated in hydrograph analysis? Explain with figure. [5]

- b) A catchment area of  $5 \text{ km}^2$  had the following rainfall pattern.

Time h	0	2	4	6	8	10	12	14
Cumulative rainfall cm	0	0.60	2.80	5.20	6.60	7.50	9.20	9.60

If  $\phi$ -index is  $0.40 \text{ cm/hr}$ , construct the excess rainfall hyetograph and also find the volume of direct runoff. [6]

6. a) A hydraulic structure is designed a discharge of  $300 \text{ m}^3/\text{s}$ . if available flood data is for  $N$  years (reduced mean =  $0.5224$ , reduced standard deviation =  $1.1124$ ) and the mean and standard deviation for annual flood series are  $140 \text{ m}^3/\text{s}$  and  $50 \text{ m}^3/\text{s}$ , respectively, calculate return period for the design flood using Gumbel's method. Also estimate 90% confidence limit, if  $f(90\%) = 1.645$ . [5+3]

- b) Consider rainfall storm in Melamchi during a recent flood event spanned for a period of 100 minutes. Observed records showed that during the first 30 minutes, 50 minutes, 84 minutes and 100 minutes are 25 mm, 40 mm, 70 mm and 80 mm, respectively. If catchment area of the watershed is  $100 \text{ km}^2$ , length of the longest flow path is 6 km, general slope of the catchment is  $0.013$  and runoff coefficient is  $0.6$ , estimate peak flow using Rational method. [6]

7. What do you mean by flow routing? A drainage basin has the following characteristics: Area =  $123 \text{ km}^2$ , time of concentration = 14hr, storage constant = 10h and inter-isochrone area distribution as below:

Travel time (hr)	0-2	2-4	4-6	6-8	8-10	10-12	12-14	14-16	16-18
Inter-isochrone area ( $\text{km}^2$ )	4	10	21	24	18	20	12	9	5

Compute the flood hydrograph by using Clark's method. [2+6]

\*\*\*

TRIBHUVAN UNIVERSITY  
INSTITUTE OF ENGINEERING  
**Examination Control Division**  
2078 Bhadra

Exam.	Regular		
	Level	BE	Full Marks
Programme	BCE	Pass Marks	32
Year / Part	III / I	Time	3 hrs.

**Subject: - Engineering Hydrology (CE 606)**

- ✓ Candidates are required to give their answers in their own words as far as practicable.
- ✓ Attempt All questions.
- ✓ The figures in the margin indicate Full Marks.
- ✓ Graph paper will be provided.
- ✓ Assume suitable data if necessary.

1. What is a hydrologic cycle? Why do we need to study hydrologic cycle and water budget equation? [1+3]
2. a) What are common causes of inconsistencies in rainfall data? Please demonstrate applications of mass curves with appropriate illustrative examples. [3+3]
- b) Mean and standard deviations of annual rainfall estimated based on seven stations in a catchment are 143 mm and 31.6 mm, respectively. For a 7% error in the estimation of mean rainfall, do we need additional rain gauges in the catchment? If yes, what are the minimum numbers of additional rain gauges required to be established in the watershed. [5]
3. a) A reservoir of a hydropower project has a surface area of 2 km<sup>2</sup>. Estimate volume of water evaporated from the reservoir in March (30 days), if temperature = 25°C, relative humidity = 70%, wind speed at 2m above the ground surface is 12 km/h, and saturation vapor pressure at 25°C is 23.76 mm of Hg. Take Meyer's coefficient as 0.36. [5]
- b) Daily (24-hrs) rainfall observed over a catchment of 1 km<sup>2</sup> is 10 cm. A Horton's curve with a coefficient (K) of 0.5 hr<sup>-1</sup> indicated an initial and final infiltration capacities of 0.8 cm/hr and 0.3 cm/hr, respectively. If an evaporation pan (pan coefficient = 0.7) installed in the catchment indicated 0.5 cm drop in the water level during the 24 hours of its operation, determine runoff from the catchment. [5]
4. a) During a flood flow the cross section of area of a river were measured as 60 m<sup>2</sup> for u/s and 45 m<sup>2</sup> for d/s at two sections 6 km apart. Wetted perimeters of these sections were 18 m and 14 m respectively. Elevation difference between u/s and d/s bed of the river was 0.45m. Estimate the flood discharge of the river. Take Manning's rugosity coefficient = 0.025 and eddy loss coefficient = 0.15. [8]
- b) Explain the methods practiced in Nepal for the estimation of runoff from an ungauged basin. [6]
5. a) Discuss how different factors affect flood hydrograph. What are various methods for baseflow separation? [3+3]
- b) Observed streamflow in a catchment (Area = 600 km<sup>2</sup>) from a storm event of 4 hours' duration tabulated hereunder. If baseflow is 10 m<sup>3</sup>/s, derive 4 hr unit hydrograph. [8]

Time(hr)	0	4	8	12	16	20	24	28	32	36	40	44	48
Observed flow (m <sup>3</sup> /s)	10	100	230	190	130	100	70	60	50	30	20	15	10

6. a) Using given data for annual discharge in a section of a river from year 2000 to 2009. [6+4]

(i) Calculate sample mean, sample standard deviation and sample coefficient of skewness.

(ii) What would be the probability of the flood of magnitude  $250 \text{ m}^3/\text{s}$  occurring in the next year?

Year	2000	2001	2002	2003	2004	2005	2006	2007	2008	2009
Discharge ( $\text{m}^3/\text{s}$ )	33.9	31.7	31.5	59.6	50.5	38.6	43.4	28.7	32.0	51.8

Reduced mean  $\bar{y}_n = 0.4952$ , Reduced Standard Deviation ( $\sigma_n$ ) = 0.9497.

b) Define the terms exceedance probability, recurrence interval and frequency factor. [6]

7. a) What are the processes that Clark's method considers in the transformation of excess precipitation to runoff? How are they achieved? [3]

b) Route the following hydrograph through a river reach with routing parameters K and x as 10 and 0.20, respectively. Take outflow discharge at the start of inflow flood as  $5 \text{ m}^3/\text{s}$ . Also estimate attenuation and lag of peak. [6+2]

Time (hr)	0	5	10	15	20	25	30	35	40
Inflow ( $\text{m}^3/\text{s}$ )	5	10	30	45	40	30	18	12	8

\*\*\*

**TRIBHUVAN UNIVERSITY**  
**INSTITUTE OF ENGINEERING**  
**Examination Control Division**  
**2078 Kartik**

Exam.	Back		
Level	BE	Full Marks	80
Programme	BCE	Pass Marks	32
Year / Part	III / I	Time	3 hrs.

**Subject: - Engineering Hydrology (CE 606)**

- ✓ Candidates are required to give their answers in their own words as far as practicable.
- ✓ Attempt **All** questions.
- ✓ The figures in the margin indicate **Full Marks**.
- ✓ Assume suitable data if necessary.

1. Explain the hydrologic cycle in nature with the help of a neat sketch. [4]
2. Discuss three different methods of determining the average depth of rainfall over a catchment. [6]
3. Following are the rain gauge observations during a storm. Construct mass curve of precipitation, hyetograph and maximum depth-duration curve. [6]

Time since commencement of storm(min)	Accumulated rainfall (cm)
5	0.1
10	0.2
15	0.8
20	1.5
25	1.8
30	2.0
35	2.5
40	2.7
45	2.9
50	3.1

4. Discuss briefly methods used to estimate evaporation from a lake. [6]
5. Following are the monthly pan evaporation data (Jan-Dec) near Kathmandu in a certain year in cm. 16.7, 14.3, 17.8, 25.0, 28.6, 21.4, 16.7, 16.7, 16.7, 21.4, 16.7, 16.7. The water spread area in a lake nearby in the beginning of January in that year was 2.80 km<sup>2</sup> and at the end of December it was measured as 2.55 km<sup>2</sup>. Calculate the loss of water due to evaporation in that year. Assume a pan coefficient of 0.7. [6]
6. For ungauged basins, how would you determine the monthly flow from rainfall? Explain any two methods. [8]
7. The high flow water surface elevations of a stream at two section 10 km apart are 306.920 m and 306.650 m. The cross-sectional area and wetted perimeters are as follows:

Section	Area (m <sup>2</sup> )	Wetted perimeter (m)
A	73.3	26.80
B	93.4	30.23

- Assume  $n = 0.02$ . The eddy loss coefficient is 0.30 for gradual expansion and 0.10 for gradual contraction. Estimate the discharge at the stream. Section A is upstream of B. [8]
8. Define flood hydrograph, Direct Run of Hydrograph (DRH) and Unit Hydrograph. Write the different methods of base flow separation in hydrograph analysis. [8]

9. The ordinates of a 2-h UH are given below. Derive the ordinates of a 3-h UH by S-curve method. [6]

Time (hr)	0	2	4	6	8	10	12
Ordinates of 2-h UH	0	12	48	78	114	72	54

10. Write the equations of flood prediction by rational and empirical methods. Also write the limitations and appropriate uses of these equations. [6]

11. For a river the estimated flood peaks for two return periods by the use of Gumbel's method are given below:

Return period (yrs)	Peak flood ( $m^3/s$ )
100	1020
50	850

What flood discharge in this river will have a return period of 500 yrs? [8]

12. A drainage basin has the following characteristics: Area =  $120 \text{ km}^2$ , time of concentration = 14 h, storage constant = 10 h and inter-isochrone area distribution as below:

Travel time (hr)	0-2	2-4	4-6	6-8	8-10	10-12	12-14	14-16	16-18
Inter-isochrone area ( $\text{km}^2$ )	3	10	20	26	18	18	13	8	4

Compute the flood hydrograph by using Clark's method. [8]

\*\*\*

Exam.	Back		
	Level	BE	Full Marks
Programme	BCE	Pass Marks	32
Year / Part	III / I	Time	3 hrs.

**Subject: - Engineering Hydrology (CE 606)**

- ✓ Candidates are required to give their answers in their own words as far as practicable.
- ✓ Attempt All questions.
- ✓ The figures in the margin indicate Full Marks.
- ✓ Semi-log graph is provided.
- ✓ Assume suitable data if necessary.

1. a) In a certain catchment, inflow rate into the catchment due to rainfall is given by equation  $I=2t \text{ m}^3/\text{s}$ . If loss in the catchment is neglected, determine the change in storage in catchment with in 3 hr duration. [4]
- b) Justify the uses of Hydrology in Engineering Design. [3]
2. For a station A, the recorded annual 24 hr maximum rainfalls are given below. [8]

Estimate the 24 hr maximum rainfall with return periods of 50 years by using provided semi log graph.

Year	1950	51	52	53	54	55	56	57	58	59	60	61	62	63	64	65
Ppt (cm)	13.0	12.0	7.6	14.3	16.0	9.6	8.0	12.5	11.2	8.9	8.9	7.8	9.0	10.2	8.5	7.5

3. a) Calculate PET for May month by Penman method. [8]
  - Mean monthly temperature = 20°C
  - Mean RH = 75%
  - Mean Sunshine hoar = 10 hr.
  - Potential Sunshine hour = 13.5 hr.
  - Wind velocity at 2m height = 8 km/hr.
  - Albedo = 0.028
  - Upper terrestrial solar radiation = 14.4 mm of Hg/day
  - Latitude = 27°; Longitude = 86°
  - Saturated vapour pressure at 20°C = 11mm of Hg
  - Slope of Saturated vapour pressure = 1.42 mm/°C

- b) A storm with a 15.0 cm precipitation produced a direct runoff of 8.7cm. The time distribution of storm is as follows.

Time from start (hr)	1	2	3	4	5	6	7	8
Incremental rainfall in each hr (cm)	0.6	1.35	2.25	3.45	2.7	2.4	1.5	0.75

Estimate the  $\Phi$ -index of the storm. [5]

4. a) Define catchment. What are the factors affecting runoff from a catchment? [1+5]
- b) For the purpose of discharge measurement in a stream by Slope-Area method the following data has been obtained. [8]

	U/S Section	Middle Section	D/S Section
Area (m <sup>2</sup> )	105.75	102.63	96.63
Wetted perimeter (m)	64.25	60.20	58.00
Gauge Reading (m)	315.5	-	315.15
Manning's Roughness	0.025	0.027	0.029

Determine the stream discharge for length between U/S and D/S sections as 260 m assuming coefficient of contraction  $K_c$  as 0.1.

- c) Define shifting control in stage discharge relationship. What are the causes of shifting control? [1+2]

5. a) Define unit hydrographs and explain the uses of hydrograph. [5]
- b) The ordinates of a 4 hr UH of a basin area of 300 km<sup>2</sup>. Three hundred square km measured at 1-hr internals are 6, 36, 66, 91, 106, 93, 79, 68, 58, 49, 41, 34, 27, 23, 17, 13, 9, 6, 3 and 1.5 m<sup>3</sup>/s respectively. Obtain the ordinates of a 3 hr UH of the basin using the s-curve technique. [10]
6. a) In the time series data of annual peak flood for 75 years, the mean and standard deviations are found to be equal to 5561 m<sup>3</sup>/s and 1718 m<sup>3</sup>/s respectively. Using  $\bar{y}_n = 0.556$  and  $S_n = 1.189$  (for 75 yrs). [4+4]
- i) Determine the peak flood for 0.4% probability of exceedence by Gumbel's method.
- ii) Compute 90% confidence limits for above floods, using  $f(c) = 1.6$  for 90% confidence level respectively.
- b) Explain the rational method of determining the floods. Also write down its limitations. [6]
7. A drainage Basin has the following characteristics: [6]
- Area = 110 Km<sup>2</sup>, Time of concentration = 18 h, Storage time constant = 12 h and inter-isochrones area distribution as below:

Travel Time (h)	0-2	2-4	4-6	6-8	8-10	10-12	12-14	14-16	16-18
Inter-isochrone area (km <sup>2</sup> )	3	9	20	22	16	18	10	8	4

Determine the Clark's 2h-IUH for this catchment.

\*\*\*



TRIBHUVAN UNIVERSITY  
INSTITUTE OF ENGINEERING  
**Examination Control Division**  
2075 Chaitra

Exam.	Regular / Back		
Level	BE	Full Marks	80
Programme	BCE	Pass Marks	32
Year / Part	III / I	Time	3 hrs.

**Subject: - Engineering Hydrology (CE 606)**

- ✓ Candidates are required to give their answers in their own words as far as practicable.
- ✓ Attempt All questions.
- ✓ The figures in the margin indicate Full Marks.
- ✓ A separate graph paper is provided.
- ✓ Assume suitable data if necessary.

1. Explain hydrologic cycle with neat sketches and justify its need in Engineering Hydrology. [3+2]
2. The rainfall depth with time during a storm at a station is given below. Compute maximum average intensities of the rainfall for durations 30 minutes, 1hr, 2 hr, and 5hr and plot the resulting intensity duration curve. [6]

Time (hr)	06:00	06:30	07:00	07:30	08:00	08:30	09:00	09:30	10:00	10:30	11:00	11:30	12:00
Rainfall (mm)	0	6	6	5	8	5	9	13	6	4	3	2	0

3. a) Explain the water budget and energy budget methods for estimation of evaporation. [3+3]

- b) The mass curve of an isolated storm in a 500ha watershed is as follows:

Time from strat (h)	0	2	4	6	8	10	12	14	16	18
cumulative rainfall (cm)	0	0.8	2.6	2.8	4.1	7.3	10.8	11.8	12.4	12.6

If runoff measured at the outlet is  $0.361 \text{ Mm}^3$  is baseflow, estimate the  $\phi$ -index of the storm and duration of rainfall excess. Also determine W-index if the other losses in the storm is  $0.1 \text{ Mm}^3$ . [5+1]

- c) Differentiate actual and Potential Evapotranspirations. [3]
4. a) Following are the data of gauge and discharge collected at a particular section of the river by stream gauging operation. [6+2]
  - i) Develop a gauge-discharge relationship for this stream at this section for use in estimating the discharge for a known gauge reading. What is the coefficient of correlation of the derived relationship? Use  $a = 7.5 \text{ m}$  for the gauge corresponding to zero discharge.
  - ii) Estimate the discharge corresponding to a gauge reading of  $10.5 \text{ m}$  at this gauging station.

Gauge reading (m)	Discharge ( $\text{m}^3/\text{s}$ )	Gauge reading (m)	Discharge ( $\text{m}^3/\text{s}$ )
7.65	15	8.48	170
7.7	30	8.98	400
7.77	57	9.30	600
7.8	39	9.5	800
7.9	60	10.5	1500
7.91	100	11.1	2000
8.08	150	11.7	2400

- b) Calculate the discharge in a stream by using mid-section method from provided data. A current meter is used to measure velocity at 0.6 depth and calibrated as  $V=0.3N+0.004$  [8]

Distance from right bank (m)	0	2	4	6	9	12	15	18	20
Depth (m)	0	0.50	1.10	1.90	2.2	1.8	1.1	0.7	0
Number of revolutions	0	80	83	130	121	116	100	90	0
Time (s)	0	170	110	100	100	100	100	90	0

5. a) Define storm hydrograph, direct runoff hydrograph and baseflow. Explain the methods to separate base flow from hydrograph with clear sketches. [3+3]
- b) Following are the ordinates of hydrograph from a catchment area of  $770\text{km}^2$  due to 6-hr rainfall. Derive the ordinates of flood hydrograph due to 3.3cm and 5.5cm effective rainfall of duration 12-hr. [10]

t (hr)	0	6	12	18	24	30	36	42	48	54	60	66	72
Discharge ( $\text{m}^3/\text{s}$ )	40	65	215	360	400	350	270	205	145	100	70	50	40

6. a) Explain Rational method of flood predication. Also mention its limitations & uses. [3+3]
- b) Analysis of the annual flood peak of river of 21 years yielded a mean of  $8520\text{m}^3/\text{s}$  and standard deviation of  $3900\text{m}^3/\text{s}$ . A proposed water control project on this river is to have an expected life of 40 years. The acceptable reliability by the design policy is 85%. [4+4]
- i) Using Gumbel's Method recommend the flood discharge for this project. Take  $y_n=0.5252$  and  $S_n=1.0696$  for 21 years.
- ii) What would the 80% confidence limit of the above flood if  $f(c)=1.282$  at 80% confidence level.

7. a) What do you understand by flow routing? [2]

- b) A drainage basin has the following characteristics:  
Area =  $123\text{ km}^2$ , time of concentration=14 hr, storage constant=10h and inter-isochrone area distribution as below:

Travel Time (hr)	0-2	2-4	4-6	6-8	8-10	10-12	12-14	14-16	16-18
Inter-isochrone area ( $\text{km}^2$ )	4	10	21	24	18	20	12	9	5

- Compute the flood hydrograph by using Clark's IUH. [6]

\*\*\*

Exam.	Back		
Level	BE	Full Marks	80
Programme	BCE	Pass Marks	32
Year / Part	III / I	Time	3 hrs.

**Subject: - Engineering Hydrology (CE606)**

- ✓ Candidates are required to give their answers in their own words as far as practicable.
- ✓ Attempt All questions.
- ✓ The figures in the margin indicate Full Marks.
- ✓ Assume suitable data if necessary.

1. a) Explain double mass curve method for checking a rainfall data for consistency. [6]
- b) What factors should be considered in selecting a site for stream gauging station. [4]
- c) The catchment area of a reservoir is 1600 ha. A uniform precipitation of 8 mm/hr for 2 hour was observed on particular day. 55% run off reached the reservoir. A canal carrying a flow of  $1\text{m}^3/\text{s}$  is taken from the reservoir. The rate of evaporation was 0.8 mm/h/m<sup>2</sup>. Assuming seepage loss is 40% of evaporation loss, find the change in the reservoir level for 6 hours, if the water spread of the reservoir was 45ha. [6]
2. a) Explain the different methods of determining the average rainfall over a catchment due to a storm. [6]
- b) Calculate the potential evapotranspiration from an area near Dharan, Sunsari in the month of april by Penmans' formula. The following data are available. [10]

Latitude: 26°-49'N, Elevation (from msl) : 250.00 m  
 Mean monthly temperature : 22.5°C, Mean relative humidity: 75%  
 Mean observed sunshine hour: 10 hr Wind velocity at 2m height: 80 km/day  
 Psychrometric constant : 0.49mm of Hg/°C Reflection coefficient:0.20  
 $e_w$  : 20.4mm of Hg, A: 1.24mm/°C  $b = 0.52$ ,  $H_a = 14.9\text{mm}$  of evaporable water per day  
 Mean monthly value of possible sunshine hour (N): 12.7 hours  
 Nature of sunshine cover: closed ground green crop, where the symbols carry their usual meanings

3. a) The mass curve of an isolated storm over a watershed is given below.

Time from start (hr)	0	0.5	1	1.5	2	2.5	3	3.5	4	4.5	5
Cumulative rainfall (cm)	0	0.6	1.4	1.9	2.8	3.7	5.4	6.2	7	7.8	8.2

If the storm produced a direct run off of 3.8 cm at the outlet of the watershed, estimate the  $\phi$ -index of the storm and duration of rainfall excess. [6]

- b) The ordinates of a 2-h UH are given below. Derive the ordinates of a 3-h UH by S-curve method.

Time (hr)	0	2	4	6	8	10	12	14	16	18	20	22	24
Ordinates of 2-h UH (m <sup>3</sup> /s)	0	25	100	160	190	170	110	70	30	20	15	6	0

Calculate the flood discharge of a storm of 3h and 2h rainfall of 8 cm and 7 cm respectively. Consider  $\phi$ -index 0.3cm/hr and baseflow  $10\text{m}^3/\text{s}$ . [10]

4. a) Compute the stream discharge with the following data.

[6]

Distance from left bank	0	2	4	6	8	10	12
Depth (m)	-	0.9	2.4	2.2	1.0	0.6	-
Velocity at 0.2d	-	0.6	0.9	0.7	0.6	0.4	-
Velocity at 0.8d	-	0.4	0.6	0.5	0.4	0.3	-

- b) Explain briefly the basic principles involved in the developments of IUH by Clarks' method. [4]
- c) Following coordinates are obtained from a stream gauging stations: ( $4\text{m}^3/\text{s}$ ,  $9.55\text{m}$ ), ( $8\text{m}^3/\text{s}$ ,  $9.75\text{m}$ ) and ( $16\text{m}^3/\text{s}$ ,  $10.15\text{m}$ ). Determine the equation of rating curve and compute the discharge in the stream corresponding to a stage of  $10.40\text{m}$ . [6]
5. a) Explain the MIP and WECS methods to determine the mean monthly flows of an ungauged river basin. [4]
- b) A bridge has an expected working life of 40 years and is designed for a peak flood of 100 years return period. Estimate the risk of failure of this bridge. If a risk of 15% is acceptable, what should be the return period for it? [6]
- c) Route the following flood hydrograph through a river reach for which Muskingum coefficient  $k = 10\text{ h}$  and  $x = 0.2$ . At the start of inflow flood, the outflow discharge is  $10\text{ m}^3/\text{sec}$ . [6]

Time (h)	0	6	12	18	24	30	36	42	48	54
Inflow ( $\text{m}^3/\text{sec}$ )	14	27	60	150	135	115	85	65	30	15

\*\*\*

Exam.	Regular		
Level	BE	Full Marks	80
Programme	BCE	Pass Marks	32
Year / Part	III / I	Time	3 hrs

**Subject: - Engineering Hydrology (CE606)**

- ✓ Candidates are required to give their answers in their own words as far as practicable.
- ✓ Attempt All questions.
- ✓ The figures in the margin indicate Full Marks
- ✓ Assume suitable data if necessary.

1. a) Define hydrology and write on history of hydrometeorology studies in Nepal. [5]
- b) Describe with a neat sketch the principle of working of a tipping bucket type recording rain gauge. What are its advantages and disadvantages? [6]
- c) A catchment area has seven rain gauge stations. In a certain month the precipitation record of station D could not be measured due to the failure of instrument. Estimate the missing precipitation of D from the following data available given in the table below. [5]

Stations	A	B	C	D	E	F	G
Monthly Ppt. (cm)	12	8.5	7.6	-	5.2	8.8	9.7
Annual normal Ppt. (cm)	188	210	152	175	246	270	228

2. a) In a 3.5 hr storm following rates of rainfall were observed in successive 30 min intervals as 4, 4, 12, 8.5, 5, 5, and 8.6 mm/hr respectively. Assuming  $\phi$ -index of 4mm/hr and the initial loss of 1.2 mm; determine the total rainfall, net runoff and W-index. [6]
- b) Explain the use of a lysimeter in measuring evapotranspiration. [5]
- c) During a daily routine observation 10.8 litres of water was added to bring the water surface in the evaporation pan to the stipulated level and the nearby raingauge measured 3.6 mm of rainfall. What was the evaporation recorded for the day if the diameter of the pan is 122 cm? [5]
3. a) During a high flow water surface elevations of a stream of trapezoidal section with base width of 10m and side slope 2:1 (H:V) were noted at two sections A and B, 10 km apart as below. Find the flow discharge in the stream. [8]

Sections	Elevation of Bed (m)	Water Surface Elevation (m)	Remarks
A	503.25	505.95	Manning's Constant = 0.025
B	502.85	504.20	Eddy loss coefficient of 0.30 for expansion and 0.10 for contraction.

- b) Write the equation of the rating curve and explain with figure how the stage for zero discharge is determined? [6]

4. a) The ordinates of 4 hr unit hydrograph are given below.

Time (hr)	0	2	4	6	8	10	12	14	16	18	20	22	24
4-hr UH ordinates (m <sup>3</sup> /s)	0	9	12	28	40	52	49	36	29	20	13	10	0

The storm has successive 2 hr, 4 hr and 6 hr rainfall of 2.5, 8.0 and 9.0 cm respectively.  $\phi$ -index is of 0.15 cm/hr and base flow of 40m<sup>3</sup>/s. Determine the 2 hr UH and resulting flood hydrograph from above storm. [12]

- b) Annual flood peak flood of a river for 20 years yielded a mean value of 5460 m<sup>3</sup>/s and the standard deviation of 2950 m<sup>3</sup>/s. The proposed hydraulic project on this river has an expected life of 35 years and reliability of project is 87%.

(i) Using Gumbel's method predict the flood discharge for the project if the value of  $\bar{y}_n = 0.5402$  and  $S_n = 1.1285$ .

(ii) What discharge is to be adopted if the safety factor for flood magnitude is taken as 1.5 and also determine safety margin on this basis.

(iii) Calculate the confidence limits at 95% confidence probability  $f(c) = 1.96$  [12]

5. Route the following hydrograph through a river reach for which  $K = 12h$  and  $X = 0.20$ . At the start of the inflow flood, the outflow discharge is 10m<sup>3</sup>/s also find lag of peak and lag attenuation. [10]

Time (h)	0	6	12	18	24	30	36	42	48	54
Inflow (m <sup>3</sup> /s)	10	20	50	60	55	45	35	27	20	15

\*\*\*

Exam.	Back		
Level	BE	Full Marks	80
Programme	BCE	Pass Marks	32
Year / Part	III / I	Time	3 hrs.

**Subject: - Engineering Hydrology (CE606)**

- ✓ Candidates are required to give their answers in their own words as far as practicable.
- ✓ Attempt All questions.
- ✓ The figures in the margin indicate Full Marks.
- ✓ Necessary tables are attached herewith.
- ✓ Assume suitable data if necessary.

1. Explain water budget equation. What is the role of water budget equation in hydrology? [2+2]
2. The annual rainfall at station X and the average of annual rainfall at 25 surrounding base stations in can are given below for the period of 36 years starting from 1941 [6+1+4+3]
  - i) Check whether the data of starting X is consistent
  - ii) In which year a change in regime indicated?
  - iii) Compute the mean annual rainfall for stations X at its present site for the given 36 year period first without adjustment and secondly with the data adjusted for the change in regime.
  - iv) Compute the adjusted annual rainfall at station X for the affected period.
3. a) Starting from Horton's equation, derive an expression for total infiltration in time "t". Also draw graph showing infiltration and total infiltration vs time. [4+2]
- b) Calculate the potential evapotranspiration from an area near Simara, Bara, in the month of April by Penman's formula. The following data are available. [10]
  - Latitude: 27°N
  - Elevation (from msl): 107 m
  - Mean monthly temperature: 23°C
  - Mean relative humidity: 75%
  - Mean observed sunshine hour: 10
  - Wind velocity at 2 m height: 85 km/day
  - Nature of sunshine cover: closed ground green crop

Given:

A: 1.27mm/°C

$H_a = 15.00$  mm of evaporable water per day

Mean monthly value of possible sunshine hour (N): 12.5 hours

Saturated vapour pressure at 23°C = 21.04 mm of Hg

4. a) Calculate the flood discharge of a stream by the slope area method given the following data: [12]

Upstream flow area =  $3500 \text{ m}^2$   
 Upstream wetted perimeter = 650  
 Upstream velocity head coefficient = 1.17  
 Down stream flow area =  $3250 \text{ m}^2$   
 Down stream wetted perimeter = 621 m  
 Down stream velocity head coefficient = 1.21  
 Falling difference = 0.4  
 Reach length = 1300 m  
 Manning's coefficient  $\eta = 0.03$

- b) Describe about the use of current meter according to flow characteristics of channel. [4]

5. a) What is Unit hydrograph? What are assumptions and limitations of UH? [2+2]

- b) In a storm, the rainfall of depth 0.7cm, 0.9cm, 0.2cm, 1.0cm occurred in four successive hours. The storm hydrograph due to this storm has following hourly ordinates: [8]

0.5, 44.5, 110.5, 85.5, 102.8, 94.0, 38.4, 18.6, 10.9, 5.3, 2.9,  $0.5 \text{ m}^3/\text{s}$

If the average losses are 0.2cm/hr, estimate the hourly ordinates of unit hydrograph. Assume suitable value of base flow. Calculate 2-h UH using Scurie Method.

6. A river, whose annual flood peak can be represented by Gumbel distribution, has 100-years and 500-year return period flood of magnitude  $9900 \text{ m}^3/\text{s}$  and  $12100 \text{ m}^3/\text{s}$  respectively. The sample size is  $n = 30$ .  $\left[ \bar{y}_n = 0.536, s_n = 1.1124 \right]$  [4+4+3+3]

- i) What is the magnitude of 200 year and 1000 year flood?  
 ii) What are 95% and 80% confidence limits for 200 year and 1000 year flood if  $f(95\%) = 1.96$  and  $f(80\%) = 1.28$   
 iii) A hydraulic structure of 25 year life was designed for  $12300 \text{ m}^3/\text{s}$  peak flow. What is the hydrologic risk of the structure?  
 iv) What peak flow should be taken into consideration if you want the structure to be 99% reliable for a structure life of 25 years.

7. A drainage basin has the following Characteristics. [4]

Area =  $172 \text{ Km}^2$ ,  
 Storage constant = 10 hour  
 Time of concentration = 8 hour

The inner-isochrones area distributions are as follows

Travel Time (hr)	0-1	1-2	2-3	3-4	4-5	5-6	6-7	7-8
Inter-isochrones area ( $\text{Km}^2$ )	12	40	26	36	28	18	8	4

Determine the IUH for this catchment.

\*\*\*



Exam.	Regular		
Level	BE	Full Marks	80
Programme	BCE	Pass Marks	32
Year / Part	III / 1	Time	3 hrs.

**Subject: - Engineering Hydrology (CE606)**

- ✓ Candidates are required to give their answers in their own words as far as practicable.
- ✓ Attempt All questions.
- ✓ The figures in the margin indicate Full Marks.
- ✓ Necessary tables are attached herewith.
- ✓ Assume suitable data if necessary.

1. a) Justify the importance of study of Hydrology in civil engineering work. [4]
- b) The catchment area of a reservoir is 1400 ha. A uniform precipitation of 6 mm/hr for 2 hour was observed on particular day. 55% run off reached the reservoir. A canal carrying a flow of 1 m<sup>3</sup>/s is taken from the reservoir. The rate of evaporation was 0.5 mm/h/m<sup>2</sup>. Assuming seepage loss is 45% of evaporation loss, find the change in the reservoir level for 6 hours, if the water spread of the reservoir was 45ha. [6]
2. Annual rainfall at station X and the average of the annual rainfall at 15 nearby rain gauge stations for a period of 35 years is given below. [8+3+4]
  - i) Examine the consistency of the data at station X
  - ii) In which year did a change in regime occur? Discuss the possible reasons
  - iii) Determine the average annual rainfall at X for 35 years first without adjusting the data and later with adjustment for the change regime.
3. How you will interpret the Energy balance in a water body? Develop the relation for daily Lake Evaporation using Energy-Budget method. [2+5]
4. a) What are the factors that affect the runoff from a catchment? [3]
- b) The data pertaining to a stream-gauging operation at a gauging site are given below. The rating equation of the current meter is  $v = (0.55 N + 0.04)$  m/s where N is revolution per second, Calculate the discharge in the stream. [8]

Dist from Left edge (m)	0	1.0	4.0	7.0	10.0	13.0	16.0	17.0
Depth (m)	0	1.5	2.5	3.5	2.4	2.2	1.3	0
Revolution of current meter at 0.6d	0	40	60	120	125	50	40	0
Duration of observation (s)	0	100	100	150	150	100	100	0

- c) Define rating curve and describe its uses. [3]
5. The ordinate of 4n-uH are given: [16]

Time (hr)	0	2	4	6	8	10	12	14	16	18	20	22	24
Ordinate (m <sup>3</sup> /s)	0	30	100	150	200	160	120	80	40	30	20	6	0

A catchment has rainfall of 3.5, 2.5 and 4.5 cm in three consecutive two hours period. Assuming an average  $\phi$  index of 1.25 cm/hr and base flow of river is 50 m<sup>3</sup>/s, Determine the flood hydrograph of the catchment.

6. a) The data of observed flood peaks of a river for a period of 30 years is found to plot as a straight line on semi-log paper with return period plotted on the logarithmic scale. The largest and smallest floods in the record are  $1170 \text{ m}^3/\text{s}$  and  $195 \text{ m}^3/\text{s}$  respectively. If  $1350 \text{ m}^3/\text{s}$  is selected as a design flood, what is the probability of its being exceeded during the next 20 years? [7]
- b) Prove that for a large sample as per Gumbel's distribution, the mean annual flood will have a return period of 2.33 years. [5]
7. Explain the procedure of obtaining Clark IUH. [6]

\*\*\*

Year	Annual rainfall (mm) at X 15 stations average		Year	Annual rainfall (mm) at X 15 stations average	
1946	664	593	1964	534	562
1947	552	530	1965	491	481
1948	558	565	1966	519	484
1949	578	534	1967	456	481
1950	570	562	1968	545	582
1951	555	478	1969	534	514
1952	639	606	1970	453	496
1953	687	552	1971	474	532
1954	572	524	1972	466	540
1955	524	502	1973	478	484
1956	570	532	1974	554	621
1957	743	611	1975	433	486
1958	534	534	1976	437	600
1959	496	501	1977	453	434
1960	468	486	1978	545	547
1961	532	583	1979	560	636
1962	423	484	1980	435	478
1963	473	610			

<b>Exam.</b>	<b>New Back (2066 &amp; Later Batch)</b>		
<b>Level</b>	BE	<b>Full Marks</b>	80
<b>Programme</b>	BCE	<b>Pass Marks</b>	32
<b>Year / Part</b>	III / I	<b>Time</b>	3 hrs.

**Subject: - Engineering Hydrology (CE606)**

- ✓ Candidates are required to give their answers in their own words as far as practicable.
- ✓ Attempt *All* questions.
- ✓ The figures in the margin indicate **Full Marks**.
- ✓ Assume suitable data if necessary.

1. Explain Water balance Equation and explain each process. [4]
2. A storm commenced at 7:00 hours. The ordinates of the rainfall mass curve of this storm in mm as recorded by a recording rain gauge at 15 minute intervals are 0, 9.5, 17.0, 27.0, 40.5, 49.0, 63.0, 84.0, 95.0, 102.0, 110.0, 112.0 and 112.0. Plot the intensity duration graph by computing the maximum rainfall intensities for durations of 15, 30, 45, 60, 90, 120 and 180 minutes. [12]
3. a) Explain energy balance equation and derive evaporation equation using Bowen's ratio. [4]  
 b) For a storm of 3 hours on 50 ha catchment, the rainfall rates are as follows: [6]

Time of rain from beginning (min):	0	30	45	75	100	125	150	180
Rain fall rate (cm/hour):	0	2.5	3.5	2.0	4.8	5.2	1.8	5.3

If the  $\phi$  index of this basin is 2.5 cm/hour, calculate total rainfall, runoff in (cm) and peak discharge.

- c) Explain interception and depression storage losses. How these losses are estimated during hydrological analysis. [2+2]
4. a) Explain how stage discharge relationship is established. [4]  
 b) Explain the procedure of stream flow measurement by area-velocity method. Also, describe the mid section method for discharge computation using sketch and equations. [3+3]  
 b) What factors should be considered in selecting a site for stream gauging station. [4]
5. a) The 3 h unit hydrograph of a basin with an area of 20 km<sup>2</sup> at one hour interval are as given below 0, 0.41, 1.38, 4, 7.72, 10.06, 9.24, 6.62, 4.57, 3.86, 2.76, 2.07, 1.38, 0.83, 0.41, 0. If rainfall excess with intensity of 2.0 cm/h for a period of 4 h followed immediately by another 3 h storm with an intensity of 1 cm/h occurs on the basin, what is the peak flow produced by this rainfall and at what time after the commencement of rainfall would this peak flow occur? Assume baseflow is negligible. [10]  
 b) A 6 h unit hydrograph of a basin has a peak ordinate of 96 m<sup>3</sup>/s. When the base flow in the stream is 25 m<sup>3</sup>/s, and when the basin has reached its minimum infiltration capacity of 2.5 mm/h, a 6 h storm with 18.3 cm of total rainfall had occurred on the basin. What is the magnitude of the peak discharge in the flood hydrograph produced by this storm? [4]

6. a) The annual peak discharge of a river follows the Gumbel's extreme value distribution with a mean of  $10000 \text{ m}^3/\text{s}$  and a standard deviation of  $3000 \text{ m}^3/\text{s}$ . What is the probability that the annual peak discharge is more than  $15000 \text{ m}^3/\text{s}$ ? What is the magnitude of the peak discharge with an exceedance probability of 0.1? [Hint:

$$\alpha = \frac{1.28255}{\sigma}; \beta = \mu - 0.48\sigma \quad [8]$$

- b) Differentiate between continuous and discrete random variables. Give examples each in hydrology. Give three formulae which are used to determine the return period. [1+2+3]

7. The ordinates of the inflow hydrograph at 6 hr interval are as follows: [8]

Time (hrs)	0	6	12	18	24	30	36	42	48	54	60	66	72	78	84	90
Discharge ( $\text{m}^3/\text{s}$ )	0	50	280	610	1290	1900	2130	1900	1600	1440	1060	780	500	370	220	130

The discharge over the spillway Crest and the surcharge storage above the crest for different water surface elevations are as follows:

Water surface elevation (m)	140	141	142	143	144	145	146
Outflow Discharge ( $\text{m}^3/\text{s}$ )	0	170	482	883	1360	1905	2500
Storage $\times 10^6 (\text{m}^3)$	0.00	15.0	35.0	60.0	95.0	140.0	240.0

Determine:

- i) Maximum reservoir level
- ii) Maximum outflow rate
- iii) Reduction in the peak

\*\*\*

Exam.	Regular		
Level	BE	Full Marks	80
Programme	BCE	Pass Marks	32
Year / Part	III / I	Time	3 hrs.

**Subject: - Engineering Hydrology (CE606)**

- ✓ Candidates are required to give their answers in their own words as far as practicable.
- ✓ Attempt All questions.
- ✓ The figures in the margin indicate Full Marks.
- ✓ Assume suitable data if necessary.

1. Define the following terms: hydrological cycle, runoff, water balance and catchment. [4]
2. The catchment area of a basin may be approximated as a semicircle of radius  $r$  km with respect to the coordinate axis set up with its origin at the center of the circle and the  $x$ -axis coincident with the diameter the area lies in the first and second quadrants and the position coordinates of the rain gauge stations are  $(0,0)$ ,  $(\frac{r}{2}, \frac{r}{2})$  and  $(\frac{-r}{2}, \frac{r}{2})$  km. Show that the Thiessen weights of the gauges are given by  $\frac{0.5}{\pi}$ ,  $(0.5-0.25/\pi)$  and  $(0.5-0.25/\pi)$  respectively. [12]
3. a) The ordinates of a rainfall mass curve of a storm over a basin of area  $850 \text{ km}^2$  measured in mm at one hour interval are 0, 10, 22, 30, 39, 45.5, 50, 55.5, 60, 64 and 68. If the infiltration during this storm can be represented by Horton's equation with  $f_0 = 6.5 \text{ mm/h}$ ,  $f_c = 1.5 \text{ mm/h}$  and  $k = 0.15 \text{ /h}$ , estimate the resulting runoff volume. [10]  
 b) Write down Penman equation and explain all variables and constants involved in it. [4]
4. a) Mention the factors that should be considered for the proper selection of stream gaging site. [4]  
 b) Explain with sketch how you determine the stage for zero discharge. [6]  
 c) Find the drainage density, average length of overland flow, form factor and channel slope for a basin with the following data: [4]
 

Area of basin (A) =  $140 \text{ km}^2$   
 Distance between the outlet to the farthest point (L) =  $21 \text{ km}$   
 Elevation difference between the outlet and the farthest point (h) =  $1090 \text{ m}$   
 Total length of channels of all order ( $L_s$ ) =  $654 \text{ km}$
5. a) Describe the procedure of derivation of unit hydrograph from complex storms using appropriate expressions. [8]  
 b) Given below are ordinates of a 4 h unit hydrograph of a basin in  $\text{m}^3/\text{s}$  at one hour intervals. [6]
 

4, 25, 44, 60, 70, 61, 52, 45, 38, 32, 27, 22, 18, 14, 11, 8, 6, 4, 2, 1

What is the area of the basin?
6. The observed annual peak flood of a river in  $\text{m}^3/\text{s}$  for a period of 20 years from 1981 to 2000 are given below: [14]
 

190, 155, 298, 136, 137, 131, 140, 124, 185, 104, 91, 154, 109, 269, 164, 270, 142, 72, 130, 111.

Prepare a graph of flood peak versus the return period and hence estimate the annual peak flood with a return period of 30 years.
7. Route the following flood hydrograph through a river reach for which Muskingum coefficient  $k=10 \text{ h}$  and  $x=0.2$ . At the start of inflow flood, the outflow discharge is  $10 \text{ m}^3/\text{sec}$ . [8]

Time (h)	0	6	12	18	24	30	36	42	48	54
Inflow ( $\text{m}^3/\text{sec}$ )	14	27	60	150	135	115	85	65	30	15



Exam.	New Back (2066 & Later Batch)		
Level	BE	Full Marks	80
Programme	BCE	Pass Marks	32
Year / Part	III / I	Time	3 hrs.

**Subject: - Engineering Hydrology (CE606)**

- ✓ Candidates are required to give their answers in their own-words as far as practicable.
- ✓ Attempt All questions.
- ✓ The figures in the margin indicate Full Marks.
- ✓ Assume suitable data if necessary.

1. Explain Hydrologic cycle and water balance equations. [2+2]
2. a) Explain the different methods of determining the average rainfall over a catchment due to a storm. Discuss the relative merits and demerits of the various methods. [3+3]
- b) Explain double mass curve test for rainfall data. [6]
3. a) Explain briefly (i) Infiltration Capacity (ii)  $\Phi$ -index lake (iii) W-index [6]
- b) Explain the energy budget method of estimating evaporation from a lake. [8]
4. a) Determine the stage corresponding to zero discharge from the following data of a rating curve: [8]

Stage (m)	20.80	21.42	21.95	22.37	23.00	23.52	24.00
Discharge(m <sup>3</sup> /s)	100	200	300	400	600	800	1000

- b) Explain different methods of Stream gauge reading with sketch. [6]
5. A hydrograph for a 4,250-acre basin is shown in the accompanying sketch. The given hydrograph actually appeared as a direct runoff hydrograph from the basin, caused by net rain falling at an intensity of 0.20 in./hr for a duration of 5 hr, beginning at  $t=0$ . [4+3+3+4]

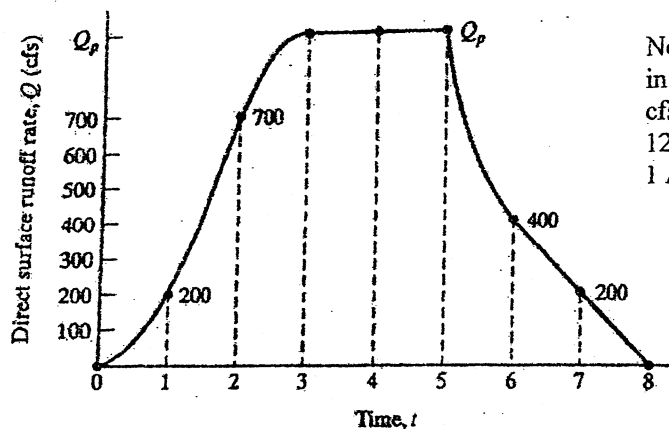

Note  
 in = inches  
 cfs = cubic feet/sec  
 12 inches = 1 foot  
 1 Acre = 43560 sq.ft

- (a) Determine the excess release time of the basin.
- (b) What percentage of the drainage basin was contributing to direct runoff 4 hr after rain began ( $t = 4$ )?
- (c) Use your response to part (b) to determine  $Q_p$  as shown in the sketch. Do not scale  $Q_p$  from the drawing.
- (d) Note that rain continued to fall between  $t = 3$  and  $t = 5$ . Why did the hydrograph form a plateau between  $t = 3$  and  $t = 5$ , rather than continue to rise during those 2 hours?

6. a) Explain Gumble's Distribution function. Derive frequency factor (k) using Gumble's distribution. [7]
- b) The flood discharge for 25 and 250 years from fitted Gumbel distribution are 90 and 550 m<sup>3</sup>/sec respectively. Estimate the flood magnitudes for 50, 500 and 1000 years by Gumbel analytically. [7]
7. A basin having 128 km<sup>2</sup> of drainage area has 22 hours and 14 hours of concentration time and storage constant respectively. Determine the IUH for this basin if inter-isochrones area distribution is as below: [8]

Travel time (hr)	0-3	3-6	6-9	9-12	12-15	15-18	18-21	21-24	24-27
Area(km <sup>2</sup> )	2	7	17	25	31	23	14	6	3

\*\*\*



04 TRIBHUVAN UNIVERSITY  
 INSTITUTE OF ENGINEERING  
**Examination Control Division**  
 2071 Chaitra

Exam.	Regular		
Level	BE	Full Marks	80
Programme	BCE	Pass Marks	32
Year / Part	III / I	Time	3 hrs.

**Subject: - Engineering Hydrology (CE606)**

- ✓ Candidates are required to give their answers in their own words as far as practicable.
- ✓ Attempt All questions.
- ✓ The figures in the margin indicate Full Marks.
- ✓ Assume suitable data if necessary.

1. Explain all hydrological process in Hydrological Cycle. [4]
2. a) Describe methods of averaging point rainfall over a catchment area with neat sketches. [6]  
 b) Explain the energy budget method of estimating evaporation from a lake. [6]
3. Calculate the potential evapotranspiration for an area over Kathmandu in the month of March by Penman Method. [14]

The flowing data is available:

- Mean Monthly temp : 10.0°C
- Mean RH : 60%
- Mean sunshine hours : 9 h
- Potential sunshine hours : 12.9 h
- Wind Velocity at 2m height : 5 Km/hour
- Albedo : 0.25
- Upper terrestrial Solar radiation = 11 mm of hg/day

Other values:

- Latitude : 28.5°
- Longitude : 84.5°
- Saturated vapor pressure at 10.0 °C = 9.2 mm of Hg
- Slope of saturate vapor pressure = 1.24 mm/°C
- Psychrometric constant = 0.49mm/°C
- Boltzman constant = 2.01\*E-9 mm/day

4. a) Compute the stream-flow from following data. The calibrated equation of current meter is: [8]

$V=0.035+0.74*N$ , where V is in m/sec and N is revolution/sec.

Distance from bank (m)	0	0.6	1.5	2.5	3.5	5.0	6.0	7.0	7.5
Water Depth (m)	0	0.3	0.75	1.2	1.7	1.3	0.7	0.3	0
No. of Revolutions	0	15	95	110	120	110	80	20	0
Time (sec)	0	45	85	95	90	100	70	40	0

- b) Explain how the monthly flows from the ungauged locations are estimated from the observed rainfall data over the catchment, in Nepal. [6]

5. A 2-hr unit hydrograph for a basin is shown in the sketch.

[6+3+5]

- (a) Determine the peak discharge (in cfs) for a net rain of 5.00 in./hr and a duration of 2 hr.
- (b) What is the total direct surface runoff (in inches) for the storm described in part (a)?
- (c) A different storm with a net rain of 0.50 in./hr lasts for 4 hr. What is the discharge at 8 p.m. if the rainfall started at 4 p.m.?

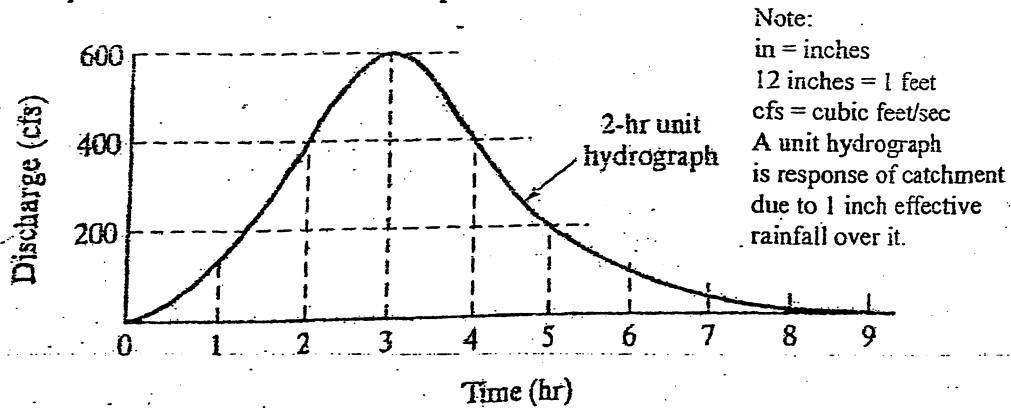

- 6. a) If the annual flood series data for a catchment are available for  $N$  consecutive years, explain a procedure to determine a flood discharge with a return period of  $T$ , (where  $T > N$ ), by using Log Pearson type III distribution method. [8]
- b) Calculate the flood discharge using Empirical method from a catchment of area 100sqkm. The catchment has longest river of 60km. The elevation difference of the river is 20m. Rainfall runoff coefficient is 0.6 and maximum daily rainfall is 200mm. [6]
- 7. Explain in detail time area method for estimating runoff hydrograph. [8]

\*\*\*

B-C-E  
III / I

03 TRIBHUVAN UNIVERSITY  
INSTITUTE OF ENGINEERING  
Examination Control Division  
2071 Shawan

Exam.	New Back (2066 & Later Batch)		
Level	BE	Full Marks	80
Programme	BCE	Pass Marks	32
Year / Part	III / I	Time	3 hrs.

**Subject:** - Engineering Hydrology (CE606)

- ✓ Candidates are required to give their answers in their own words as far as practicable.
- ✓ Attempt All questions.
- ✓ The figures in the margin indicate Full Marks.
- ✓ Assume suitable data if necessary.

1. Define Hydrological cycle and water balance equation. Write down a general water balance equation for a basin. [4]
2. a) The shape of a catchment is in the form of a pentagon ABCDE. There are 4 rain gauge stations P, Q, R and S inside the catchment. The position co-ordinates in km are: A(0,0), B(50,75), C(100,70), D(150,0), E(75,-50), P(50,25), Q(100,25), R(100,-25) and S(50,-25). If rainfalls recorded at P, Q, R and S are 90, 105, 114 and 120 mm respectively, determine the mean rainfall by Thiessen Polygon method. [6]
- b) Explain the different types of precipitation based on lifting mechanism. [6]
3. a) Calculate the free water surface evaporation in june using the Penman method from an area, whose latitude is approximately 33°N. The available data include air temperature = 30°C, wind speed at 2 m height = 10 km/h, relative humidity = 60%, mean observed sun shine hours = 12 and reflection coefficient = 0.05. [8]
- b) The infiltration capacity in a basin is represented by Horton's equation as  $f_p = 3.0 + e^{-2t}$ , where  $f_p$  is in cm/hr and 't' in hours. Assuming the infiltration to take place at capacity rates in a storm of 60 minutes during, estimate the depth of infiltration in (i) the first 30 minutes and (ii) the second 30 minutes of the storm. [3+3]
4. a) Estimate the flood discharge through a 5m-wide rectangular channel for the following data. The depth of water is 2m and 1.8m at two section 500m apart. The drop in water surface elevation is 0.25 m. Manning's roughness coefficient is 0.025, Assume eddy loss to be zero. [8]
- b) The following data were collected for a stream at a gauging station. Compute the discharge. [6]

Distance from one end of water surface (m)	Depth, d (m)	Immersion of current meter below water surface					
		at 0.6d		at 0.2d		at 0.8d	
		Rev.	Sec.	Rev.	Sec.	Rev.	Sec.
3	1.4	12	50				
6	3.3			38	52	23	55
9	5.0			40	58	30	54
12	9.0			48	60	34	58
15	5.4			34	52	30	50
18	3.8			35	52	30	54
21	1.8	18	50				

Rating equation of current meter :  $v = 0.3N + 0.05$

5. An S- hydrograph is given such that at time  $t = 0$ , its ordinate is 1cm/h and it remains so for an indefinite period of time. Determine a 2-hour unit hydrograph. Using this unit hydrograph, determine a 4- hour unit hydrograph. [8+6]

6. An analysis of an annual flood, series covering the period 1890 to 1966 on a certain river shows that the 80 year flood has a magnitude of 620000 units and 1.4 year flood has a magnitude of 215000 units. Assume the annual floods are Gumbel distributed. [6+4+4]
- What is the probability of having a flood as great as or greater than 440000 units?
  - What is the magnitude of flood having a recurrence interval of 40 years?
  - What is the probability of having 575000 units flood or a greater flood in the coming 25 years time?
7. a) Explain the concept of attenuation and lag of peak due to routing with sketch. [4]  
 b) Starting from the continuity equation, obtain the equation of reservoir routing. [4]

SATURATION VAPOR PRESSURE OF WATER

Temperature		Saturation vapor pressure, e		Slope (mm Hg/°F)
°C	°F	mb	mm of Hg	
0	32	6.11	4.58	0.30
5.0	41.0	8.72	6.54	0.45
7.5	45.5	10.37	7.78	0.54
10.0	50.0	12.28	9.21	0.60
12.5	54.5	14.49	10.87	0.71
15.0	59.0	17.05	12.79	0.80
17.5	63.5	19.00	15.00	0.95
20.0	68.0	23.38	17.54	1.05
22.5	72.5	27.25	20.44	1.24
25.0	77.0	31.67	23.76	1.40
27.5	81.5	36.71	27.54	1.61
30.0	86.0	42.42	31.82	1.85
32.5	90.5	48.89	36.68	2.07
35.0	95.0	57.07	42.81	2.35
37.5	99.5	64.46	48.36	2.62
40.0	104.0	73.14	55.32	2.95
45.0	113.0	94.91	71.20	3.66

MEAN MONTHLY SOLAR RADIATION INCIDENT AT THE EARTH'S OUTER SPACE (EXTRATERRESTRIAL RADIATION),  $L_0$ , IN MEGACALORIES PER SQUARE METER/DAY, IN NORTHERN HEMISPHERE WITH  $L = 560$  CAL/CM

Month	North latitude (°N)									
	90°	80°	70°	60°	50°	40°	30°	20°	10°	0°
January	—	—	—	1.3	3.6	6.0	8.5	10.8	12.8	14.5
February	—	—	—	1.1	3.5	5.9	8.2	10.5	12.3	13.9
March	—	1.8	4.3	6.8	9.1	11.0	12.7	13.9	14.8	15.2
April	7.9	7.8	9.1	11.1	12.7	13.9	14.8	15.2	15.2	14.7
May	14.9	14.6	13.6	14.6	15.4	15.9	16.0	15.7	15.0	13.9
June	18.1	17.8	17.0	16.5	16.7	16.7	16.5	15.8	14.8	13.4
July	16.8	16.5	15.8	15.7	16.1	16.3	16.2	15.7	14.8	13.5
August	11.2	10.6	11.4	12.7	13.9	14.8	15.3	15.3	15.0	14.2
September	2.6	4.0	6.8	8.5	10.5	12.2	13.5	14.4	14.9	14.9
October	—	0.2	2.4	4.7	7.1	9.3	11.3	12.9	14.1	15.0
November	—	—	0.1	1.9	4.3	6.7	9.1	11.2	13.1	14.6
December	—	—	—	0.9	3.0	5.5	7.9	10.3	12.4	14.3

MEAN MONTHLY VALUES OF POSSIBLE SUNSHINE HOURS

Latitude (°N)	Month											
	Jan.	Feb.	Mar.	Apr.	May	June	July	Aug.	Sept.	Oct.	Nov.	Dec.
0°	12.1	12.1	12.1	12.1	12.1	12.1	12.1	12.1	12.1	12.1	12.1	12.1
10°	11.6	11.8	12.1	12.4	12.6	12.7	12.6	12.4	12.9	11.9	11.7	11.5
20°	11.1	11.5	12.0	12.6	13.1	13.3	13.2	12.8	12.3	11.7	11.2	10.9
30°	10.4	11.1	12.0	12.9	13.7	14.1	13.9	13.2	12.4	11.5	10.6	10.2
40°	9.6	10.7	11.9	13.2	14.4	15.0	14.7	13.8	12.5	11.2	10.0	9.4
50°	8.6	10.1	11.8	13.8	15.4	16.4	16.6	15.5	12.7	10.8	9.1	8.1

\*\*\*

Exam.	Regular		
Level	BE	Full Marks	80
Programme	BCE	Pass Marks	32
Year / Part	III / I	Time	3 hrs.

Subject: - Engineering Hydrology (CE606)

- ✓ Candidates are required to give their answers in their own words as far as practicable.
- ✓ Attempt All questions.
- ✓ The figures in the margin indicate Full Marks.
- ✓ Assume suitable data if necessary.

1. Explain different prospects of Hydrological study. [4]
2. a) What can be the causes of inconsistency while recording the rainfall of a station? Explain how it can be corrected for the future use? [4]
- b) The rainfall depth with time during a storm at a station is as given: [2+6]

Time	6:00	6:30	7:00	7:30	8:00	8:30	9:00	9:30	10:00	10:30	11:00	11:30	12:00
Rainfall (cm)	0	7	5	8	9	13	10	8	6	5	3	1	0

- i) Construct the hyetograph of this storm for 30 min and 2 hours interval
- ii) Compute maximum average intensity of rainfall for 30 min, 1 hour, 2 hour in this storm and plot the resulting intensity duration curve.
3. a) Calculate the daily potential evapotranspiration by the Penman method from an area having the following characteristics: latitude = 30°N, elevation = 300 m above mean sea level, mean monthly temperature = 15°C, mean relative humidity = 70%, mean observed sunshine hours = 10, wind velocity at 2 -m height = 50 km/day and reflection coefficient is 0.05. [8]
- b) Precipitation falls on a 100 km<sup>2</sup> drainage basin according to the following schedule: [6]

Time (minute)	30	60	90	120
Rainfall intensity (cm/hr)	4	2	6	5

Determine the total storm rainfall. Also, find out  $\phi$ -index for the basin if the net storm runoff is 3 cm.

4. a) Explain the stream flow computation by slope area method. [5]
- b) Write the method of estimating monthly flows in a stream or river by MIP method in a Nepalese river. [4]
- c) What is mean by rating curve? Write the uses of rating curve. Also explain the method of drawing the rating curve in a particular section of a river. [1+2+2]
5. a) The direct runoff hydrograph due to an effective rainfall event in given by a triangle such that its base is 8 hours and its height at the midpoint of the base is 1cm/h. The duration and intensity of the effective rainfall are 4 hours and 1cm/h, respectively. Derive and sketch a 4 hour unit hydrograph. [8]
- b) A 1 hour unit hydrograph is given by a rectangle whose base is 4 hours and height is 0.25/hour. Construct an S-hydrograph using this UH. [6]
6. a) Analysis of the annual flood peak of a river for 43 years yielded a mean of 330m<sup>3</sup>/s and a standard deviation of 187 m<sup>3</sup>/s. A proposed water control project on this river is to have an expected life of 50 years. Policy decision of the project allows an acceptable reliability of 85%. Using Gumbel's method, recommend the flood discharge for this project. [9]

A table for reduced mean ( $\bar{y}_n$ ) and reduced standard deviation ( $S_n$ ) is given below:

N	40	41	42	43	44	45
$\bar{y}_n$	0.5436	0.5442	0.5448	0.5453	0.5458	0.5463
$S_n$	1.1413	1.1436	1.1458	1.1480	1.1499	1.1519

- b) Explain log pearson III distribution and its use in the prediction of flood. [5]

7. For what purpose time area method is used? Explain time area method using a time area histogram of a catchment and a set of effective rainfall hydrograph over it. Comments on its drawbacks. [1+5+2]

SATURATION VAPOR PRESSURE OF WATER

Temperature		Saturation vapor pressure, $e_s$		Slope (mm Hg/°F)
°C	°F	mb	mm of Hg	
0	32	6.11	4.58	0.30
5.0	41.0	8.72	6.54	0.45
7.5	45.5	10.37	7.78	0.54
10.0	50.0	12.28	9.21	0.60
12.5	54.5	14.49	10.87	0.71
15.0	59.0	17.05	12.79	0.80
17.5	63.5	20.06	15.00	0.95
20.0	68.0	23.38	17.54	1.05
22.5	72.5	27.25	20.44	1.24
25.0	77.0	31.67	23.76	1.40
27.5	81.5	36.71	27.54	1.61
30.0	86.0	42.42	31.82	1.85
32.5	90.5	48.89	36.68	2.07
35.0	95.0	57.07	42.81	2.35
37.5	99.5	64.46	48.36	2.62
40.0	104.0	73.14	55.32	2.95
45.0	113.0	94.91	71.20	3.66

MEAN MONTHLY SOLAR RADIATION INCIDENT AT THE EARTH'S OUTER SPACE (EXTRATERRESTRIAL RADIATION)  $L_e$  IN MM OF EVAPORABLE WATER/DAY, IN NORTHERN HEMISPHERE WITH  $L = 560$  CAL/G.

Month	North latitude (°N)									
	90°	80°	70°	60°	50°	40°	30°	20°	10°	0°
January	—	—	—	1.3	3.6	6.0	8.5	10.8	12.8	14.5
February	—	—	1.1	3.5	5.9	8.3	10.5	12.3	13.9	15.0
March	—	1.8	4.3	6.8	9.1	11.0	12.7	13.9	14.8	15.2
April	7.9	7.8	9.1	11.1	12.7	13.9	14.8	15.2	15.2	14.7
May	14.9	14.6	13.6	14.6	15.4	15.9	16.0	15.7	15.0	13.9
June	18.1	17.3	17.0	16.5	16.7	16.7	16.5	15.8	14.8	13.4
July	16.8	16.5	15.8	15.7	16.1	16.3	16.2	15.7	14.8	13.5
August	11.2	10.6	11.4	12.7	13.9	14.8	15.3	15.3	15.0	14.2
September	2.6	4.0	6.8	8.5	10.5	12.2	13.5	14.4	14.9	14.9
October	—	0.2	2.4	4.7	7.1	9.3	11.3	12.9	14.1	15.0
November	—	—	0.1	1.9	4.3	6.7	9.1	11.2	13.1	14.6
December	—	—	—	0.9	3.0	5.5	7.9	10.3	12.4	14.3

MEAN MONTHLY VALUES OF POSSIBLE SUNSHINE HOURS

Latitude (°N)	Month											
	Jan.	Feb.	Mar.	Apr.	May	June	July	Aug.	Sept.	Oct.	Nov.	Dec.
0°	12.1	12.1	12.1	12.1	12.1	12.1	12.1	12.1	12.1	12.1	12.1	12.1
10°	11.6	11.8	12.1	12.4	12.6	12.7	12.6	12.4	12.9	11.9	11.7	11.5
20°	11.1	11.5	12.0	12.6	13.1	13.3	13.2	12.8	12.3	11.7	11.2	10.9
30°	10.4	11.1	12.0	12.9	13.7	14.1	13.9	13.2	12.4	11.5	10.6	10.2
40°	9.6	10.7	11.9	13.2	14.4	15.0	14.7	13.8	12.5	11.2	10.0	9.4
50°	8.6	10.1	11.8	13.8	15.4	16.4	16.0	13.5	12.7	10.8	9.1	8.1

\*\*\*

Exam.	Level	Full Marks	80
	BE		
Programme	BCE	Pass Marks	32
Year / Part	III / I	Time	3 hrs.

Subject: - Engineering Hydrology (CE606)

- ✓ Candidates are required to give their answers in their own words as far as practicable.
- ✓ Attempt All questions.
- ✓ The figures in the margin indicate Full Marks.
- ✓ Normal graph papers will be provided.
- ✓ Assume suitable data if necessary.

1. Why the study of hydrology is important for engineers for planning and designing of water resources projects in Nepal? Explain the significant features of global water balance with necessary equation. [2+2]
2. a) In what way you can present the precipitation data? What are the benefits of each method? Explain the method of drawing Intensity Duration Frequency (IDF) curve. [3+2+3]  
 b) A catchment has seven raingauge stations. In a year the annual rainfall in cm recorded by the gauges are as follows: 130, 142.1, 118.2, 108.5, 165.2, 102.1, 146.9 for a 5% error in the estimation of the mean rainfall, calculate the minimum number of additional stations required to be established in the catchment. [4]

3. A 4-hour storm occurs over a 80 km<sup>2</sup> watershed. The details of the catchment are as follows: [14]

Sub basin (km <sup>2</sup> )	φ index (mm/h)	Hourly Rainfall (mm)			
		1 <sup>st</sup> hour	2 <sup>nd</sup> hour	3 <sup>rd</sup> hour	4 <sup>th</sup> hour
15	10	16	48	22	10
25	15	16	42	20	8
35	21	12	40	18	6
5	16	15	42	18	8

Calculate the runoff from the catchment and the hourly distribution of the effective rainfall for the whole catchment.

4. Calculate the discharge of river section as given: [14]

Distance (m)	0	1	2	3	4	6	8	12	16	17	18	19
Depth (m)	0	1	4.3	7.2	8.5	7.4	5.6	4.7	3.5	2.1	1.4	0
Revolution / s ± 0.2d	0	1.4	1.0	2.6	2.9	2.7	2.5	2.3	2.1	1.8	1.5	0
Revolution / s ± 0.8d	0	.7	1.2	1.8	2.0	1.9	1.7	1.5	1.3	1.1	1.0	0

The current meter formula is  $v = 0.02 - N_s - 0.02$ ,  $v$  = velocity (m/s) and  $N_s$  = revolution per minute.

5. In a storm the rainfall excess of 0.5 cm, 0.0 cm and 0.8 cm occurred in three successive hours. The storm hydrograph due to this storm has the hourly ordinates (Q) as given below: 0.5, 44.5, 110.5, 85.5, 102.8, 94.0, 38.4, 18.6, 10.9, 5.3, 2.9, 0.8 (cumecs). If there is a constant base flow of 0.5 cumecs, find the hourly ordinates of unit hydrograph. If 2 successive storms of 6.5 cm and 10.5 cm of 3 hours duration and φ-index of 0.2 cm/hr occurred in the same catchment, what is the peak flow from the catchment? [9+5]

6. a) Mention the steps for the computation of flood of return period T using graphical method. [4]  
 b) The following are the annual peak flow data ( $m^3/s$ ) of a river from 1990 to 2006: [10]

Year	1990	1991	1992	1993	1994	1995	1996	1997	1998
Peak discharge ( $m^3/s$ )	1400	4160	2580	2910	2250	1360	2280	2540	3900
Year	1999	2000	2001	2002	2003	2004	2005	2006	
Peak discharge ( $m^3/s$ )	3420	6170	2160	1360	5440	1340	3360	2800	

Compute flood magnitude with 50 year return period (T) using Log-Pearson type III distribution. For T = 50 year, obtain frequency factor ( $K_T$ ) for the computed coefficient of skewness ( $C_s$ ) using following table.

$C_s$	0	0.1	0.2	0.3	0.4	0.5	0.6	0.7	0.8	0.9	1
$K_T$	2.054	2.107	2.159	2.211	2.261	2.311	2.359	2.407	2.453	2.498	2.542
$C_s$	1.2	1.4	1.6	1.8	2	2.2	2.5	3			
$K_T$	2.626	2.706	2.78	2.848	2.912	2.970	3.048	3.152			

7. Explain the procedure of deriving Clark UH.

\*\*\*

[8]



Exam.			
Level	BE	Full Marks	80
Programme	BCE	Pass Marks	32
Year / Part	III / I	Time	3 hrs.

**Subject: - Engineering Hydrology (CE606)**

- ✓ Candidates are required to give their answers in their own words as far as practicable.
- ✓ Attempt All questions.
- ✓ The figures in the margin indicate Full Marks.
- ✓ Normal graph papers will be provided.
- ✓ Assume suitable data if necessary.

1. What is hydrological cycle? Draw a neat sketch of the cycle showing all components. [1+3]
2. a) How would you determine optimum number of rain gauges to be installed in a given catchment? [6]
- b) Explain Intensity Duration Curve and Depth Area Curve. [6]
3. a) What is the difference between potential evapotranspiration (PET) and Actual evapotranspiration (AET)? Explain the penman's method for the estimation of PET from an area. [2+4]
- b) The infiltration of a catchment can be represented by the equation  $f = 15 + 50e^{-0.9t}$ . If the rainfall intensity of 45mm/hr occurs continuously for 10 hour from a catchment of area  $12\text{km}^2$ , calculate [2+2+2+2]
  - i) Total runoff volume generated from that catchment
  - ii) Total infiltration volume at the period
  - iii) Calculate time from the start of rainfall from which runoff started
  - iv) Show your all (above three) results in infiltration curves
4. a) The stage and discharge data of a river are given below. Derive the equation of rating curve (stage-discharge relationship) to predict the discharge for a given stage. Assume the value of stage for zero discharge as 161.0m. [8]

Stage (m)	161.3	161.7	161.9	162.8	163.4	163.8	164.5	165.4	165.7
Discharge ( $\text{m}^3/\text{s}$ )	30	120	210	450	650	825	900	1000	1050

- b) Describe the principle of slope-area method for the measurement of flood discharge in a stream. Explain the procedure to compute peak discharge using method. [3+3]
5. A 1 hour unit hydrograph of a small catchment is triangular with peak value of  $3.6\text{ m}^3/\text{s}$  occurring at 2 hours from the start and a base time of 6 hours. Following urbanization over a period of two decades, the infiltration index  $\phi$  has decreased from  $0.7\text{cm/h}$  to  $0.4\text{cm/h}$ . Also one hour unit hydrograph has now peak of  $6.0\text{ m}^3/\text{s}$  at 1 hours from start and time of base is 4 hours. If a design storm has intensities of  $4\text{cm/hour}$  and  $3\text{cm/h}$  for two consecutive one hour intervals. [14]
  - a) Estimate the percentage increase in the peak storm runoff due to urbanization.
  - b) The volume of flood runoff due to urbanization.
6. The project life of headworks is 50 years. The flood discharges at risk 63.58303% is 4200 cumecs. The average flood is 3500 cumec, which is derived from long term historical data using Gumbel distribution. Calculate the discharge from 500 year return period and risk 39.49939%. Prepare a Gumbel graph paper using normal arithmetic graph paper. Plot these three discharges on Gumbel paper. [14]
7. What is linear reservoir? Explain the procedure to obtain Clark UH from time area method. [2+6]

\*\*\*



Exam.	Regular		
Level	BE	Full Marks	80
Programme	BCE	Pass Marks	32
Year / Part	III / I	Time	3 hrs.

**Subject: - Water Supply Engineering (CE 605)**

- ✓ Candidates are required to give their answers in their own words as far as practicable.
- ✓ Attempt All questions.
- ✓ The figures in the margin indicate Full Marks.
- ✓ Assume suitable data if necessary.

1. What is the necessity of water supply scheme in the community? Describe the impacts of water supply schemes. [2+2]
2. What are the criteria for selection of water source? [4]
3. Determine the population of a city in the year 2090 by (i) Arithmetical increase method (ii) Geometrical increase method, (iii) Decrease rate growth rate method. The census population of the city is as follows: [8]

Year	2030	2040	2050	2060	2070
Population	28,000	38,000	48,000	58,000	70,000

Also calculate the total water demand for the city in 2090 using 110 lpcd.

4. a) What are the types of impurities according to its characteristics and state? Describe water washed diseases and its preventive measures. [2+2]  
b) Define water quality standards for drinking purpose. Discuss about significance of WHO guidelines for drinking water quality. [4]
5. Explain with sketches the operation and characteristics of a wet reservoir intake for an earth dam. What are the factors that should be considered to ensure maximum stability and safety of intake works? [8]
6. a) Discuss about the unit operation and process with respect to corresponding impurities removal. Also describe how the temperature and diameter affects the theory of particle settlement in sedimentation tank. [4+4]  
b) In a continuous flow, settling tank 20 m long and 3.5 m deep, what detention time would you recommend for effective removal of 0.02 mm particles at 25°C? Assume specific gravity of particles = 2.65. Also determine the percentage of 0.01 mm particles removed in the same tank at 15°C. [8]  
c) Describe the causes and effects of hardness in relation to water supply system. How can permanent hardness be removed in water? Calculate the quantity of bleaching powder required to be added in the treatment plant to disinfect 2 MLD of water if the dose of chlorine is 0.5 ppm and 30% chlorine available in bleaching powder. [2+2+4]
7. a) List out the different type of layout systems in the distribution system. Explain with examples why different types of layout systems are suggested in the distribution system. [2+6]  
b) A village has a design year demand of 80000 liter per day. This demand is to meet by continuous system of supply from a spring source with safe yield 0.8 lps. The consumption pattern is as follows:

Time: hour	Consumption %
5.00 – 7.00	20
7.00 – 12.00	30
12.00 – 17.00	20
17.00 – 19.00	25
19.00 – 5.00	5

- Is a balancing storage tank necessary? Calculate its capacity if necessary. [8]
8. Describe the factors that should be considered while selecting pipe materials. What are advantages and disadvantages of PPR pipes? [1+3]
  9. What is the function of air valve? Describe its working with a neat sketch. [4]



TRIBHUVAN UNIVERSITY  
INSTITUTE OF ENGINEERING  
Examination Control Division  
2079 Baishakh

Exam.	Back		
Level	BE	Full Marks	80
Programme	BCE	Pass Marks	32
Year / Part	III / I	Time	3 hrs.

**Subject: - Water Supply Engineering (CE 605)**

- ✓ Candidates are required to give their answers in their own words as far as practicable.
- ✓ Attempt All questions.
- ✓ The figures in the margin indicate Full Marks.
- ✓ Assume suitable data if necessary.

1. Recommend a neat sketch of a schematic diagram for a rural water supply scheme in Terai area of Nepal showing its components with their functions. [4]
2. What are the various sources of water used in water supply schemes? Discuss their merits and demerits from quality and quantity point of view. [6]
3. Baseline survey of a newly developing rural municipality in 2021 AD has the following information:  
Populations = 6000 with annual growth rate of 2%; No of cows = 3050; No. of buffalos = 2000; No. of goats = 2500; No. of ducks = 1000; No of chickens = 6000; No of rural municipality = 1 and no of students in a school = 150 boarders and 1500 day scholars.  
Neglecting the fire demand, calculate water demand of the area considering a base period of 3 and design period of 20 years. [8]
4. a) What are E-coil? Are they harmful to human being? Why and how is their presence tested in water for drinking purposes? [4]  
b) Total hardness value obtained from the complete analysis of a water sample is found to be 400 ppm. The analysis further showed that the concentrations of the calcium and magnesium cat-ions causing hardness found to be equal. If value of carbonate hardness is 150 ppm, calculate  
(i) The concentration of calcium and magnesium,  
(ii) The value of total alkalinity in ppm and the value of NCH. [4]
5. What are the points to be considered for the selection of site for intake? With a neat sketches, describe the construction of river intake. [8]
6. a) Explain the theory of filtration and its limitations. [8]  
b) Determine the size of a rectangular sedimentation tank having its length as twice of its width to settle the particles with settling velocity of 0.2 mm/sec with a settling period of 3 hours to treat a water for population of 25000 with a peak allowance of 110 lpcd. Draw neat sketch including all dimensions. [8]  
c) Discuss the factors affecting disinfection. Calculate the quantity of bleaching powder required per day for disinfecting 5 ML per day. The does of chlorine has to be 0.6 ppm and the bleaching powder contains 30% of available chlorine. [8]

7. a) Describe briefly on the type and the suitability of distribution layout system with their pros and cons. Also recommend key improvements over traditional layout system. [8]

b) Determine the capacity of a service reservoir of diameter 30m for a town having 1,00,000 populations with peak per capita water demand of 110 liters/day. The water demand is to be fulfilled by a river flowing under gravity by a continuous system. The variations of the demand are as follows.

Time (hours)	05-07	07-12	12-17	17-19	19-05
Demand(%)	25	30	15	20	10

Also determine the water level in the tank at 12 hrs. [8]

8. Why pipe joints are required? Describe collar joint with neat sketch. [1+2]

9. Describe cutoff valve and reflux valve with necessary sketches. [3]

\*\*\*

TRIBHUVAN UNIVERSITY  
INSTITUTE OF ENGINEERING  
**Examination Control Division**  
2078 Bhadra

Exam.	Regular		
Level	BE	Full Marks	80
Programme	BCE	Pass Marks	32
Year / Part	III / I	Time	3 hrs.

**Subject: - Water Supply Engineering (CE 605)**

- ✓ Candidates are required to give their answers in their own words as far as practicable.
- ✓ Attempt **All** questions.
- ✓ The figures in the margin indicate **Full Marks**.
- ✓ Assume suitable data if necessary.

1. Enlist objectives of water supply system focusing for rural water supply in Nepal. Draw its schematic diagram mentioning components. [2+2]
2. Describe the selection criteria to choose a source of water supply? [4]
3. A survey was carried out in 2019 in rural area of Nepal and following data were obtained: Population = 4460, Offices = 3 nos, Day students = 654, boarding students = 145, Cows and buffaloes = 480, goats and pigs = 855. A 15% of net water demand is considered as compensation for losses and wastage. Estimate the total water demand for the scheme if base period is 2 years and design period is 20 years. Consider the annual population growth rate as 1.77%. [8]
4. a) Describe fecal-oral transmission route with a neat sketch. What are the preventive measures that can be adopted to avoid or break this route? [2+2]  
b) The total hardness of water is 160 mg/l and carbonate hardness is 70 mg/l. All the three bi-valent metallic ions causing hardness are same. Determine the non-carbonate hardness, alkalinity and concentration of bi-valent metallic ions. [4]
5. What is an intake? What are the functions of intake? Enlist the factors affecting the site selection of intake. [1+2+5]
6. a) Design the plain sedimentation tank for treating 4 MLD of water. Assume necessary data suitably. Sketch designed sedimentation tank with dimensions. [8]  
b) Propose the number and dimensions of a rapid sand filter for a town having population of 1,20,000 numbers. Assume average water supply rate as 120 lpcd with a filtration rate of 3000 lph/m<sup>2</sup> and length width ratio as 1.5. [8]  
c) Explain the forms of chlorination? What are the factors affecting chlorination? [6+2]
7. a) Which layout of distribution of water do you prefer for a haphazardly growing city of Nepal and why? With a neat sketch, enlist its advantages and disadvantages. How you can improve those layout with minimum works? [2+6]  
b) Determine the storage capacity of balancing reservoir by analytical method for 10 hours pumping (5 am to 10 am and 2 pm to 7 pm) and continuous water supply. The population of a city is 3 million has a water demand of 110 lpcd. The consumption pattern as follows: [8]

Time	5-10	10-14	14-19	19-22	22-25
Consumption	35	15	25	15	10
8. What are the requirements of a good pipe? Explain the expansion joint with a neat sketch. [2+2]
9. Why Break Pressure Tank is necessary in water supply scheme? Explain BPT with neat sketch. [4]

TRIBHUVAN UNIVERSITY  
INSTITUTE OF ENGINEERING  
Examination Control Division  
2078 Kartik

Exam.	Back		
	Level	BE	Full Marks
Programme	BCE	Pass Marks	32
Year / Part	III / I	Time	3 hrs.

**Subject: - Water Supply Engineering (CE 605)**

- ✓ Candidates are required to give their answers in their own words as far as practicable.
- ✓ Attempt All questions.
- ✓ The figures in the margin indicate Full Marks.
- ✓ Assume suitable data if necessary.

1. Draw the schematic flow diagram of gravity water supply system for rural area and briefly describe major objectives of each component. [4]
2. List out the major sources of water with respect to quantity and quality. Briefly describe them with examples. What are the key factors to be considered while selecting a water source? [3+3]

3. Estimate the total water requirement for rural village for the year 2092 BS by forecasting the population by incremental increase method with the following Census data. [8]

Year (BS)	2018	2028	2038	2048	2058	2068
Population	7200	8100	9300	11000	13000	16000

There are 3 school (350 days and 50 boarder scholars), livestock (5000 chickens, 1500 goats and 60 cows), 2 health posts with 10 beds capacity and other offices with 100 staffs altogether. Neglect the fire demand for rural area.

4. a) Describe pathways of fecal oral disease transmission route with neat sketch. [4]
- b) What will be the MPN/100 ml, if 6 tubes for each diluted samples of 1.0 ml, 0.1 ml, 0.01 ml and 0.001 ml are taken and the no. of positive tubes are found to be 3, 4, 2 and 0 respectively in a multiple tube fermentation technique of coliform analysis? [4]
5. Illustrate and describe the spring intake arrangement. Describe its protection works with neat sketch and their components. [4+4]
6. a) In continuous flow settling tank of 15 m length, 4 m width and 2.5 m effective depth, what detention time would you recommend to remove 96% of particles having diameter of 0.015 mm and specific gravity 2.65 at 15°C. Does the tank is enough to remove 99% of particles having size 0.020 mm at same conditions? [8]
- b) Design and draw a neat sketch of a rapid sand filter for a community having 5000 number of persons. Assume necessary data with appropriate values. [8]
- c) Briefly describe the break point chlorination with sketch. What are the affecting factors in chlorination process? Discuss. [8]
7. a) Describe dead end system of water distribution system with a neat sketch. Also point out its merits and demerits. [4+4]
- b) A rural area has a design year demand of water 20000 liters per day. The demand is met by a continuous system of supply from a river source with measured safe yield of 0.25 lps. The consumption pattern is as follows: Estimate the capacity of the storage tank. What will be the water level in the tank at time of 10 if the cross section area of the tank is "A". [8]

Time (Hour)	5-7	7-12	12-17	17-19	19-5
Consumption	25	35	20	20	0

8. List out three commonly used materials for water supply pipe with their merits and demerits. [3]
9. What is break pressure tank? Describe it with a neat sketch. [1+2]



TRIBHUVAN UNIVERSITY  
INSTITUTE OF ENGINEERING  
**Examination Control Division**  
2076 Chaitra

Exam.	Regular		
Level	BE	Full Marks	80
Programme	BCE	Pass Marks	32
Year / Part	III / I	Time	3 hrs.

**Subject: - Water Supply Engineering (CE 605)**

- ✓ Candidates are required to give their answers in their own words as far as practicable.
- ✓ Attempt All questions.
- ✓ The figures in the margin indicate Full Marks.
- ✓ Assume suitable data if necessary.

1. Draw a schematic diagram of typical urban water system and briefly describe the function of each components. [4]
2. Differentiate deep and shallow well. Briefly describe the water characteristics of those wells. [4]
3. Calculate the design discharge for design year 2040 for Rural Municipality in Ilam District. the data collected in survey year 2020 is as below:  
Survey year population = 1600; Population growth rate = 2.3% per year; number of buffalos = 350; Number of cows = 500; Number of goats = 900; Number of chickens = 2500; Number of boarder students = 100; Number of day scholar students = 550; Number of offices = 5; Health post = 2 nos. [8]
4. a) Why examination of water is necessary? What are E-coli and coliform? How their presence are tested in water? [2+1+1]  
b) A water sample of 700 ml with pH 6 is mixed to another water sample of 500 ml with pH 8. What will be the pH of the mixture? [4]
5. What are the components of intake? Describe with the help of neat sketches a reservoir intake for an earth dam. [1+7]
6. a) Design a settling tank for a town having design year population of 41,600 numbers with a water supply rate of 120 lpcd. The detention period is expected as 4 hours, length width ratio as 4 and effective depth as 3.5 m. Also check for SOR and velocity. Sketch neat diagram with dimensions as designed. [8]  
b) Determine the size of slow sand filter for a present population of 15000 nos, design period = 20 yrs, annual population growth rate = 2.5%, water consumption = 45 lpcd, and also draw the section of slow sand filter. [5+3]  
c) Why high content of iron and manganese is objectionable in drinking water? List the methods of removal of iron and manganese from water. Describe briefly various methods commonly used for aeration of water. [1+2+5]
7. a) Differentiate between continuous and intermittent supply system. Explain layout of distribution system which is adopted in town or cities which have developed haphazardly without proper planning? [2+6]  
b) Design pipelines AB and BC for the following pipe network. A minimum pressure of 1 kg/cm<sup>2</sup> is required at the tap. Take Hazen William constant as 100 which pipe class have to be designed. Is there any option to reduce high level pipe class and how? [8]

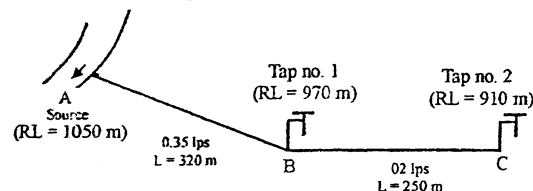

8. Describe briefly the process of pipe laying in a water supply system. [4]
9. How do you define protection and maintenance of a water supply system? Discuss different types of maintenance work with examples. [1+3]

12  
13  
14  
15

16  
17  
18  
19

TRIBHUVAN UNIVERSITY  
INSTITUTE OF ENGINEERING  
Examination Control Division  
2076 Ashwin

Exam.	Back		
Level	BE	Full Marks	80
Programme	BCE	Pass Marks	32
Year / Part	III / I	Time	3 hrs.

*Subject: - Water Supply Engineering (CE 605)*

- ✓ Candidates are required to give their answers in their own words as far as practicable.
- ✓ Attempt All questions.
- ✓ The figures in the margin indicate Full Marks.
- ✓ Assume suitable data if necessary.

1. What are the major components of water supply system? Discuss briefly with neat sketch. [4]
2. Describe and illustrate the possible water supply scheme components used in rural and urban area in Nepal. [4]
3. Data obtained from a baseline survey of a newly formed municipality in year 2016 A.D. are as follows. Population = 45,000, No. of day scholar students in school = 9500, No. of big animals = 8000, No. of small animals = 15000. There are twenty offices, two hospital with total 50 beds. Calculate the water demand of that municipality in design year with base period of 2 years and design period of 20 years. Assume the population growth rate of the community is 1.5% per annum and fire fighting as per National Board of fire under writers. [8]
4. How do you determine dissolved oxygen of water sample in lab using titrimetric method? Also, briefly illustrate about MPN. [4+4]
5. Sketch and explain the general river intake arrangement. What are the points to be considered for the selection of intake site? [8]
6. a) In a sedimentation tank (dimensions: 6m wide, 18m long and 3m depth), 4 million litres of water passes per day. Calculate a) detention period and b) surface overflow rate. Check the values with standard range. [8]
- b) Design a rapid sand filter for the population of 45,000 in the year 2021. Water demand is 110 lpcd, annual population growth rate is 2.1%. [8]
- c) Differentiate between super chlorination and break point chlorination. What is the significance of residual chlorine? Calculate the daily quantity of bleaching powder required in a treatment plant of capacity 20 million liters per day. Consider chlorine dose of 0.5mg/l assuming 35% chlorine available in bleaching powder. [8]
7. a) Determine velocity, head loss and discharge in the pipes BC, CD, BF and FD. If the diameter of pipes BC, CD, BF and FD are 1200 mm, 800 mm, 1000 mm, and 1000 mm respectively. Assume length of pipes are 100 m and coefficient of friction,  $f=0.03$ . [8]

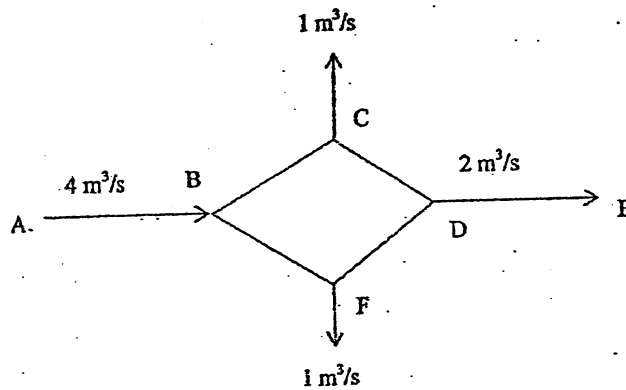

- b) A rural area has designed year demand of water 22000 liters per day. The demand is met by a continuous system of supply from a river source with measured safe yield of 0.25 lps. The consumption pattern is as follows:

[8]

Time (Hour)	5-7	7-12	12-17	17-19	19-5
Consumption (%)	25	35	20	20	0

8. Write down the requirements of good pipe material. Describe briefly polyethylene (PE), Polyvinyl chloride (PVC), and Polypropylene random copolymer (PPR) pipes.
9. Write short notes on: (*Any Two*)
- a) Aeration
  - b) Service Reservoir and Clear water reservoir
  - c) Fecal oral transmission route

[4]

[2×2]

\*\*\*

TRIBHUVAN UNIVERSITY  
INSTITUTE OF ENGINEERING  
**Examination Control Division**  
2075 Chaitra

Exam.	Regular / Back		
Level	BE	Full Marks	80
Programme	BCE	Pass Marks	32
Year / Part	III / I	Time	3 hrs.

**Subject: - Water Supply Engineering (CE 605)**

- ✓ Candidates are required to give their answers in their own words as far as practicable.
- ✓ Attempt All questions.
- ✓ The figures in the margin indicate Full Marks.
- ✓ Assume suitable data if necessary.

1. Discuss with sketch the main components to be provided in the public water supply scheme for a hilly area of Nepal. [4]
2. Extraction of excessive ground water is leading towards lowering ground water table in Kathmandu. List out the possible actions for its sustainable solution. [4]
3. What is meant by design period, base period and peak hour demand? Describe the various types of water demand and discuss the factors which affect the rate of demand in water supply scheme. [8]
4. Discuss the types of impurities present in water. Describe about the fecal-oral transmission route with a neat schematic diagram. [4+4]
5. Define intake. what are the components of intake? Sketch and explain general river intake arrangement. [8]
6. a) A water treatment plant has to purify water for a town with daily peak demand of 9 million liters. Design a rectangular sedimentation tank assuming the velocity of flow as 20cm/min and detention period of 4 hours. [8]
- b) A town with population of 35,000 in the year 2019 AD has a water supply rate of 200 lpcd. Determine the number and dimensions of the slow sand filter for the design year 2039. Assume that annual population growth rate of the town as 4.2%. Sketch with showing each components. [6+2]
- c) State different aspects of chlorination for disinfecting water. Briefly describe the affecting factors in disinfection process. [4+4]
7. a) Water is to be supplied to a municipality in Nepal with forecasted population of 150,000 with 110 litres per capita per day. The variation in water demand is mentioned below. Calculate the capacity of service reservoir considering pumping at 6-9am and 6-9pm respectively. Neglect the fire demand and use analytical method. [8]

Time	6am – 9am	9am – 12 noon	12 noon – 3pm	3pm – 6pm	6pm - 9pm	9pm – 6am
% Demand	30	10	10	20	25	5

- b) What are the general considerations to be observed in the planning of distribution system? Under what condition would you recommend the use of intermittent system of water supply? What are its drawbacks? [8]
8. Enlist three materials commonly used for water supply pipe. Also describe their merits and demerits. [4]
9. What are the purpose of valves in pipelines? Describe the working and function of cutoff valve with neat sketch. [4]

Exam.	Back		
	Level	BE	Full Marks
Programme	BCE	Pass Marks	32
Year / Part	III / I	Time	3 hrs.

**Subject: - Water Supply Engineering (CE605)**

- ✓ Candidates are required to give their answers in their own words as far as practicable.
- ✓ Attempt All questions.
- ✓ The figures in the margin indicate Full Marks.
- ✓ Assume suitable data if necessary.

1. Define Potable and Wholesome water. Also, describe the function of water in human body. [2+2]
2. Define wet and dry river intake with neat sketch and briefly describe its operation and maintenance with showing all major components in sketch. [4]
3. The survey is carried out in year 2074 B.S. for a water supply scheme for a new municipality with the per capita water allowance of 110 lpcd. Calculate the total water demand at the service year considering the base and design period of 5 and 30 years respectively if population is forecasted from (a) Geometrical increase method and (b) Decreased rate of growth method. The collected census data of the town is as follows: [8]

Year B.S.	2034	2044	2054	2064	2074
Population (Nos)	45,500	49,000	53,000	57,000	59,500

4. How can you determine MPN of water sample? Also, discuss about significance of WHO guidelines for drinking water quality. [4+4]
5. Design slow sand filter for treating water with 15,000 populations in the community considering water demand of 100 litres per capita per day and filtration rate of 150 litres/hour per square meter. After designing, sketch with all components and their dimension. [4+4]
6. A rectangular sedimentation tank is to be provided to treat water for 3000 persons at per capita daily allowance of 120 liters. Propose the dimensions of the sedimentation tank assuming detention period of 6 hours. [8]
7. Explain how iron and manganese is removed from aeration process. How many kg/day of bleaching powder is required to treat 5 MLD of water if the chlorine demand of water is 0.1 mg/l and residual chlorine requirement is 0.4 mg/l? Assume bleaching powder contains 35% of available chlorine. [4+4]
8. Discuss about the treatment process and impurities removal. Explain the affecting factors in sedimentation tank. Why we use coagulants in water treatment process? [8]
9. A village has design year population of 500 nos and water demand of 45 lpcd. The demand is met by a continuous system of supply from a spring source with safe yield of 0.28 lps. The consumption pattern is as follows:

Time (Hours)	05 - 07	07 - 12	12 - 17	17 - 19	19 - 05
Consumption (%)	15	45	10	20	10

- Is balancing reservoir necessary? Calculate its capacity if necessary and justify your answer. [8]
10. Describe continuous and intermittent systems of water supply with its advantages. What are the selection criteria of pipe materials in water supply system? [2+2]
  11. Enlist types of layouts of distribution systems in water supply. Illustrate about most suitable layout of distribution system in water supply with positive and negative aspects. [8]
  12. Describe the service connection from main pipe to private building service layout with neat sketch and use of each components. [4]

Exam.	Regular		
Level	BE	Full Marks	80
Programme	BCE	Pass Marks	32
Year / Part	III / I	Time	3 hrs.

**Subject: - Water Supply Engineering (CE605)**

- ✓ Candidates are required to give their answers in their own words as far as practicable.
- ✓ Attempt All questions.
- ✓ The figures in the margin indicate Full Marks.
- ✓ Assume suitable data if necessary.

1. What are the objectives of water supply? Enlist the requirements of wholesome water. [2+2]
2. Among the available sources, which type of source is preferred in the public water supply system in a community for the hilly region of Nepal and why? [4]
3. Data obtained from a baseline survey of a newly formed rural municipality in year 2018 A.D. are as follows. Population = 15,000, No. of day students in school = 1500, No. of big animals = 6500, No. of small animals = 8000. There are altogether 10 offices, one hospital with total 25 beds, No. of tea shops = 12, No. of health post = 2 and number of police check post = 2 Neglect fire fighting demand. Calculate the water demand of that rural municipality in design year with base period of 2 years and design period of 20 years. Assume the population growth rate of that community is 1.8 % per annum. [8]
4. What is an indicator organism? How can you determine E-coli from the membrane filter technique in laboratory? [1+3]
5. Describe spring intake constructed in a rural area with a neat sketch showing plan, elevation, section and protection work. [8]
6. What do you mean by coagulant? What are the affecting factors in coagulation? Briefly describe. [8]
7. Describe the construction of Rapid Sand Filter with neat sketch and its designed considerations. Briefly describe its operation and maintenance showing components in sketch. [8]
8. A layout of water distribution is as shown below. Design pipelines AB, BC and CD considering Hazen-William's constant of 120. Minimum pressure required at B, C and D is 12m of water. [8]

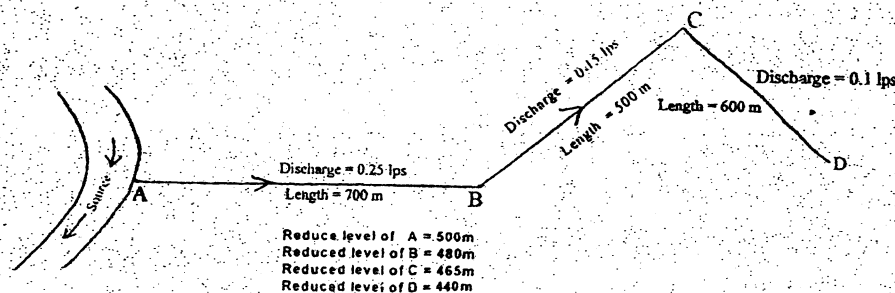

9. Define break point chlorination. Describe in details about how pH and temperature affect the relative distribution of hypochlorous (HOCl) and hypochlorite ions (OCl<sup>-</sup>) in unit process of chlorination. [2+6]

10. A rural area has a design year demand of water 20,000 liters per day. The demand is met by an intermittent system of supply two times a day at 7-10 and 17-20 (altogether 6 hrs) [8]

Time (Hour)	5-7	7-12	12-17	17-20	20-5
Consumption (%)	20	35	10	25	10

Determine the balancing reservoir capacity for that rural area.

11. Describe briefly on the layout of distribution system with their pros and cons. Also recommend improvements over traditional layout system. [6+2]

12. Describe reflux valve and air relief valve with necessary sketches. [2+2]

\*\*\*



02 TRIBHUVAN UNIVERSITY  
 INSTITUTE OF ENGINEERING  
**Examination Control Division**  
 2074 Ashwin

Exam.	Back		
Level	BE	Full Marks	80
Programme	BCE	Pass Marks	32
Year / Part	III / I	Time	3 hrs.

**Subject: - Water Supply Engineering (CE605)**

- ✓ Candidates are required to give their answers in their own words as far as practicable.
- ✓ Attempt All questions.
- ✓ The figures in the margin indicate Full Marks.
- ✓ Assume suitable data if necessary.

1. Differentiate between (a) pure and impure water, (b) potable and wholesome water and (c) polluted and contaminated water. [4]
2. What are the criteria for the selection of water sources in hill and terrai area? [4]
3. Population of a town in Nepal as obtained from the census report is as follows: [8]

Year A.D.	1971	1981	1991	2001	2011
Population	15000	21000	27000	34000	42000

Determine the water demand in the year 2030 if the town has fully plumbed house. Take industrial demand as 20% total demand and water losses wastage as 15 of the total demand. Neglect other demands.

4. Describe the various types of living organisms present in water. Discuss their effects on human health. [8]
5. Why an intake structure is necessary for water supply scheme? Describe a dry river intake with neat sketch showing all major components and operation. [8]
6. a) Derive a Stoke's law for the settlement of particles? Under what conditions it is suitable to use for the design of sedimentation tank. Include the temperature effect in the law. [8]
- b) A town with survey year population of 10000 and a growth rate of 1.5% per annum has a base period of 5 years, design period of 15 years and average water consumption rate of 150 lpcd. Taking length as twice of its width, propose number, length and width of a slow sand filter with filtration rate of 150 l/m<sup>2</sup>/day to treat water in this average flow rate and sketch also. [8]
- c) A settling tank is designed for an overflow rate of 4000 liters per m<sup>2</sup> per hour. What percentage of particles of diameter (a) 0.05 mm (b) 0.02 mm, will be removed in this tank at 10°C. [8]
7. a) Calculate the storage required to supply the demand shown in the following table if the inflow of water to the reservoir is maintained at a uniform rate throughout 24 hours. [8]

Time (hours)	00-04	04-08	08-12	12-16	16-20	20-24
Demand (million litres)	0.18	0.27	0.33	1.00	0.82	0.54

- b) With a neat sketch, discuss grid iron system of water distribution including its advantages and disadvantages. [8]
8. Briefly describe the purpose and use of expansion joint and flanged joint with sketch. [4]
9. Describe the components and purpose in layout connection from main pipe to household service with sketch. [4]



Exam.	Regular		
Level	BE	Full Marks	80
Programme	BCE	Pass Marks	32
Year / Part	III / I	Time	3 hrs.

**Subject: - Water Supply Engineering (CE605)**

- ✓ Candidates are required to give their answers in their own words as far as practicable.
- ✓ Attempt All questions.
- ✓ The figures in the margin indicate Full Marks.
- ✓ Assume suitable data if necessary.

1. Explain the functions of different components of a rural water supply scheme with a neat sketch. [4]
2. What is infiltration gallery? With a neat sketch, describe its construction. [4]
3. The survey data collected for a water supply scheme in a village of Nepal is given below: [8]  
Survey year = 2013  
Based period = 3 years  
Design period = 25 years  
Population = 1250  
Cows = 200  
Goats = 500  
Chicken = 5000  
Annual population growth rate = 1.5%  
Day scholar students in a school = 100  
Boarder students in a school = 10  
No. of Health post = 1  
No. of tea shop = 1  
No. of VDC office = 1  
Neglect demand for fire fighting  
Calculate average water demand for the design year.
4. The hardness of a water sample was found to be 300 ml/l as  $\text{CaCO}_3$ . The hardness was found due to Ca and Mg ions only. The concentrations of these ions are equal in water. The water analysis showed the concentration of  $\text{HCO}_3$  was 150 mg/l. Calculate (i) the concentrations of Ca and Mg, (ii) alkalinity of water and (iii) carbonate hardness and non-carbonate hardness of water. [8]
5. Describe the characteristics of dry and wet river intakes with neat sketch. What modification will you make if the river bank is unstable? [8]
6. a) Describe the construction of slow sand filter with neat sketches and its design consideration. [8]  
b) A settling tank is designed for an overflow rate of 4000 liters per  $\text{m}^2$  per hour. What percentage of particles of diameter (a) 0.05 mm (b) 0.02 mm, will be removed in this tank at  $10^\circ\text{C}$ . [8]  
c) Describe briefly the types of aeration methods with sketches. [8]

7. a) A part of the water distribution network is shown in figure below.

[8]

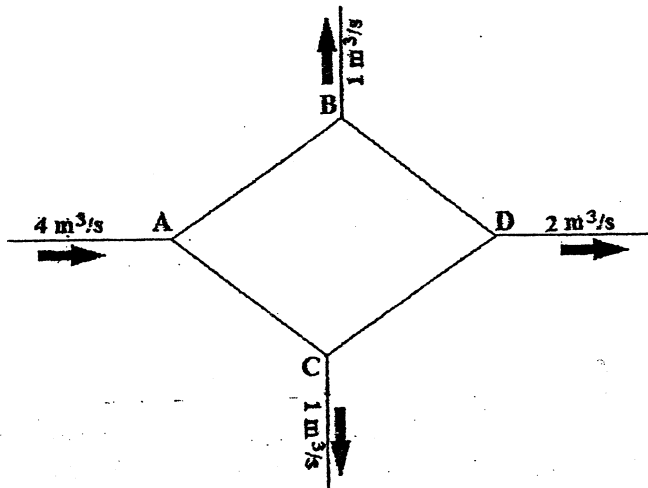

If the diameter of pipes AB, BC, AC and CD are 1200 mm, 800 mm, 1000 mm and 1000 mm respectively, Calculate the head loss and velocity in pipes AB, BC, AC and CD. Assume length of all the pipes are 100 m and coefficient of friction,  $f = 0.03$

b) In a part of water distribution system, the source is located at a 'point A' with a RL of 210 m, a 'point B' with RL of 154 m is at a distance of 700 m from 'point A' and another 'point C' with RL of 126 m is at a distance of 550 m from 'point B'. Pipe line AB carries a discharge of 44 lps and pipe line BC carries a discharge of 18 lps. Taking minimum residual head as 10 m and Hazen William's coefficient as 100 for pipes, design pipe AB and BC.

[8]

8. Describe the various types of layouts of the water distribution system with their merits and demerits.

[4]

9. What are the purposes of valves in pipeline? With a neat sketch, describe a reflux valve.

[4]

\*\*\*

Exam.	New Back (2066 & Later Batch)		
	Level	BE	Full Marks
Programme	BCE	Pass Marks	32
Year / Part	III / I	Time	3 hrs.

**Subject: - Water Supply Engineering (CE605)**

- ✓ Candidates are required to give their answers in their own words as far as practicable.
- ✓ Attempt All questions.
- ✓ The figures in the margin indicate Full Marks.
- ✓ Assume suitable data if necessary.

1. Draw typical layout of water supply schemes for rural and urban areas. Describe briefly the function of each component. [4]
2. Differentiate between shallow and deep wells with neat sketch and their characteristics with respect to water quality and quantity. [4]
3. Data obtained from a baseline survey of a newly formed municipality in year 2016 A.D are as follows. No. of day students in school = 2500, No. of big animals = 4000, No. of small animals = 6400. There are twenty offices, one hospital with 50 beds. The total water demand of municipality in design year with base period of 2 years and design period of 20 years is 800 m<sup>3</sup>. The population growth rate of that community is 1.9% per annum. Determine the population in survey year. [8]
4. a) Describe in detail about the multiple tube fermentation technique for the determination of E-coli in lab. [4]
- b) Determine total alkalinity and concentration of calcium and magnesium in the water sample if both calcium and magnesium ions were found equal. Total hardness is 280 mg/l and carbonate hardness is 75 mg/l. [4]
5. Sketch and explain the general river intake arrangement. What are the points to be considered for the selection of site for intake? [8]
6. a) Describe, with the help of a neat sketch, a rapid sand filter. Explain its working and cleaning. [8]
- b) Design a rectangular sedimentation tank for water treatment in a city with population of 20000. Considering the settling velocity of particles 0.4 mm/sec, Length = 2xWidth and detention period of 2 hours. [8]
- c) Design a water softener for a flow 20,000 l/hr, hardness = 450 mg/l as CaCO<sub>3</sub>, allowable hardness after treatment = 50 mg/l as CaCO<sub>3</sub> ion exchange capacity of the resin = 20 kg /m<sup>3</sup> of the resin, regeneration period = 7.5 hours. [8]
7. a) Describe briefly on the layout of distribution system with their pros and cons. Also recommen improvements over transitional layout system. [8]
- b) The water demand of a city is 10,000 m<sup>3</sup>/day. The water demand is to meet from the river flowing under gravity to the reservoir. The water is supplied to the consumers from the reservoir by continuous system. Calculate the capacity of service reservoir for the consumption pattern as shown in figure below. [8]

Time	05-07	07-12	12-17	17-19	19-05
Water consumption (%)	25	30	15	20	10

Find the water level in the reservoir at 6, 12, 18 and 24 hours.

8. Enlist three materials commonly used for water supply pipe. Also describe their merits and demerits. [4]
9. Describe a public stand post with neat sketches. [4]



Exam.	New Back (2066 & Later Batch)		
Level	BE	Full Marks	80
Programme	BCE	Pass Marks	32
Year / Part	III / 1	Time	3 hrs.

**Subject: - Water Supply Engineering (CE605)**

- ✓ Candidates are required to give their answers in their own words as far as practicable.
- ✓ Attempt All questions.
- ✓ The figures in the margin indicate Full Marks.
- ✓ Assume suitable data if necessary.

1. Discuss about the importance of water. Enlist the objectives and necessity of water supply schemes. [4]
2. Discuss the selection criteria to choose a source of water supply. [4]
3. Determine the population of the town in the year 2088 by (a) Arithmetical increase method (b) Geometrical increase method and (c) Decreased rate of growth method. The census population of the city is as follows: [8]

Year	2068	2058	2048	2038	2028
Population	65,500	57,000	47,000	37,000	29,000

Calculate the design year and total water demand for a Nepalese town assuming the per capita demand of 120 lpcd.

4. Define indicator organisms. Describe the procedure of determining coliform in laboratory by MPN method. [8]
5. What are the components of intake? Enlist and discuss the factors governing the site selection for intake. [8]
6. a) In a continuous flow settling tank 30 m long and 3 m deep, what detention time would you recommend for effective removal of 0.03 mm particles at 25°C. Assume specific gravity of particles = 2.65. Also determine the percentage of 0.025 mm particles removed in the same tank at 20°C. [8]
- b) Describe the effects of hardness. Explain zeolite water softener with advantage and disadvantages. [8]
- c) Mention the common methods of disinfection. Calculate the daily quantity of alum and bleaching powder required in a treatment plant of capacity 25 million liters per day. Consider optimum doses of alum as 15 mg/l and chlorine doses of 0.5 mg/l assuming 30% chlorine available in bleaching powder. [8]
7. a) Describe the design steps for designing water supply distribution system with mentioning design criteria. [8]
- b) A village has design year demand of water 20000 liters per day. The demand is met by a continuous system of supply from a spring source with measured yield of 0.25 lps. The consumption pattern is as follows. [8]

Time (Hours)	5-7	7-12	12-17	17-19	19-5
Consumption (%)	25	35	20	20	0

Is balancing storage tank necessary? Calculate its capacity if necessary. Justify your answer.

8. What are the requirements of good pipe material? [4]
9. What is the function of air valve? Describe its working with a neat sketch. [4]

Exam.	Regular		
Level	BE	Full Marks	80
Programme	BCE	Pass Marks	32
Year / Part	III / I	Time	3 hrs.

**Subject: - Water Supply Engineering (CE605)**

- ✓ Candidates are required to give their answers in their own words as far as practicable.
- ✓ Attempt All questions.
- ✓ The figures in the margin indicate Full Marks.
- ✓ Assume suitable data if necessary.

1. What do you understand by water supply system? Describe its historical development. [4]
2. Determine the storage capacity of impounded reservoir for a city with a water demand of  $4 \times 10^6 \text{m}^3$  per month. The run off discharge in river is given as in table: [4]

Month	April	May	June	July	Aug.	Sep.	Oct.	Nov.	Dec.	Jan.	Feb.	March
Inflow ( $10^6 \text{m}^3$ )	5.1	5.9	8.3	8.9	7.5	5.0	3.5	3.0	2.0	1.6	2	2.4

3. Briefly describe the factors affecting water demand and variation of hourly water demand. [8]
4. a) Describe about the fecal-oral transmission route with neat schematic diagram. [4]  
 b) The total hardness of water is 150 mg/l and carbonate hardness is 60 mg/l. All the three bi-valent metallic ions causing hardness are same. Determine the non-carbonate hardness, alkalinity and concentration of bi-valent metallic ions. [4]
5. With neat sketches describe the factors that should be considered while constructing the spring intake. [8]
6. a) Explain briefly the theory of settlement of discrete particles through quiescent liquids. How do you modify the theory to consider the temperature affect? [8]  
 b) The population of a city is 50,000. Design a rapid sand filter including design of filter media, base material and underdrainage system. [8]  
 c) What dose will be necessary pH = 8 if 0.5 mg/l of total chlorine is required for disinfection of water at pH = 7.0. Find the contact time required at pH = 8.0, if it is given that initially 10 minutes contact time is required at pH = 7.0. Take  $n = 1.5$  in the equation  $c^n t = \text{constant}$ ,  $K_i = 2.7 \times 10^{-8} \text{ mol/lit}$ . [8]
7. a) Describe a purpose and construction of service reservoirs with neat sketches. [8]  
 b) Determine the velocity, head loss and discharge in the pipes BC, CD, BF and FD  
 The length of pipe BC, CD, BF and FD are 100 m, 200 m, 300 m and 100 m respectively and dia of all pipes are 0.1m and Darcy's coefficient of friction,  $f = 0.03$ . [8]

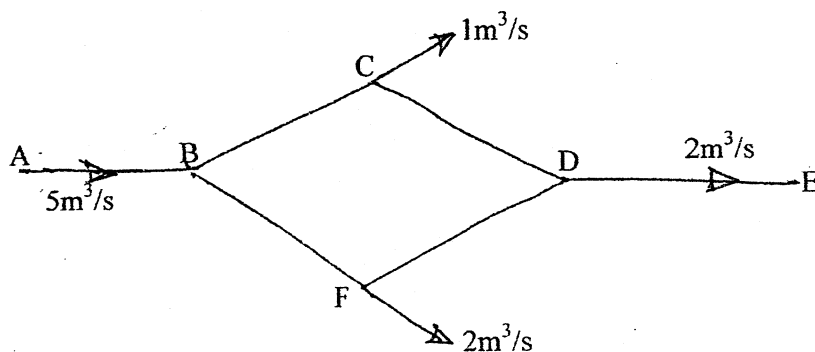

8. Describe briefly the process of pipe laying and joining. [4]
9. Why break pressure tank is necessary in a water supply scheme? Discuss its construction with neat sketches. [4]



Exam.	New Batch (2066 & later Batch)		
Level	BE	Full Marks	80
Programme	BCE	Pass Marks	32
Year / Part	III / I	Time	3 hrs.

**Subject: - Water Supply Engineering (CE605)**

- ✓ Candidates are required to give their answers in their own words as far as practicable.
- ✓ Attempt All questions.
- ✓ The figures in the margin indicate Full Marks.
- ✓ Assume suitable data if necessary.

1. Differentiate potable and wholesome water, polluted and contaminated water. Write down the requirements of wholesome water in brief. [4]
2. Why ground water source is generally chosen for supplying drinking water scheme? What are the common ground water quality parameters? Discuss them with reference to health and treatment. [4]
3. Safe yield of a proposed spring is 5 liter per second and per capita water demand is 65 lpcd. Calculate the current population that can be taken under the scheme if design period is 20 years and population growth rate is 1.7% per annum. [8]
4. The hardness of a water sample was found to be 300 ml/l as CaCO<sub>3</sub>. The hardness was found due to Ca and Mg ions only. The concentrations of these ions are equal in water. The water analysis showed the concentrations of HCO<sub>3</sub>, was 150 mg/l. Calculate (i) the concentrations of Ca and Mg (ii) alkalinity of water and (iii) carbonate hardness and non-carbonate hardness of water. [8]
5. Generally, which type of intake is used in hilly area of Nepal? Why? Describe such intake with a neat sketch showing plan, elevation, section and protection work. [8]
6. a) A rectangular sedimentation tank is to treat 10 MLD of water. A detention basin of width to length ratio of 1/3 is proposed to trap all particles larger than 0.04 mm is size. Assuming a specific gravity of particles at 20°C is 2.65. Compute the tank dimensions. If the depth of the tank is 3.5 m, calculate the detention time. [8]
- b) Determine amount of bleaching powder required annually in a water treatment plant treating 10MLD of water if 0.3 ppm of chlorine dose is required. Available bleaching powder contains 27% of chlorine. Describe the break point chlorination in water treatment process. [8]
- c) Write down the purpose of aeration. Describe methods of aeration with sketch. [8]
7. a) Design pipes PQ, PR and RS. Minimum pressures have to be maintained at 1 kg/cm<sup>2</sup> in all taps. Take Hazen William constant C = 110 [10]

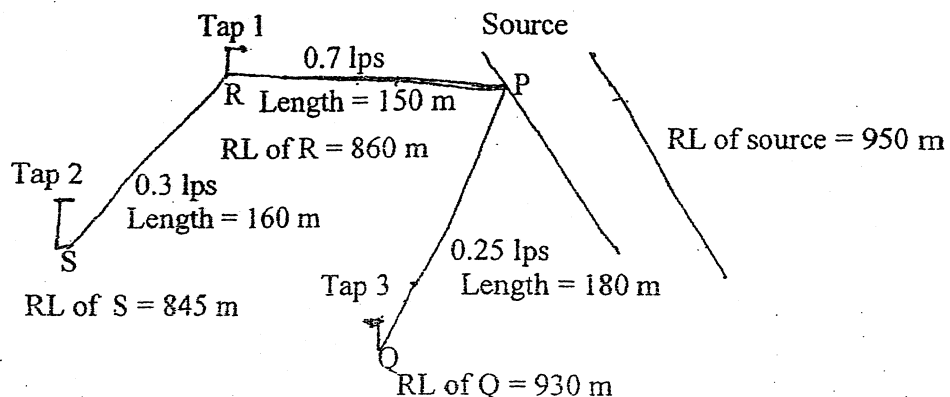

- b) Briefly describe the layout of distribution system. [6]
8. Write down the requirements of good pipe material. Describe briefly concrete pipe, C.I pipe and PPR pipe. [4]
9. Briefly describe the requirements of the public stand post along with its importance in rural areas. [4]

Exam.	Regulation	Full Marks	80
Level	BE	Pass Marks	32
Programme	BCE	Time	3 hrs.
Year / Part	III / I		

**Subject: - Water Supply Engineering (CE605)**

- ✓ Candidates are required to give their answers in their own words as far as practicable.
- ✓ Attempt All questions.
- ✓ The figures in the margin indicate Full Marks.
- ✓ Assume suitable data if necessary.

1. Draw a schematic diagram for rural and urban water supply scheme. Describe the functions of each component. [4]
2. Differentiate between shallow and deep wells. Discuss their suitability with respect to water quantity and quality. [4]
3. Calculate the design discharge for design year 2030 for a village in Surkhet District. The data collected in survey year 2015 is as below: [8]  
Survey year population = 1500  
Population growth rate = 2.0% per year  
Number of buffalos = 345  
Number of cows = 450  
Number of goats = 800  
Number of chickens = 2000  
Number of boarder students = 64  
Number of day scholar students = 450  
Number of offices = 3
4. a) Describe the types of water washed diseases and its preventive measures. [4]  
b) The analysis of water showed the following results in mg/l: [4]  
Ca = 65; Mg = 35; Na = 101.5; K = 21.5; HCO<sub>3</sub> = 248; SO<sub>4</sub> = 221.8  
Find the total hardness, carbonate hardness and non-carbonate hardness.
5. Which type of intake do you recommend in rural hilly area? Describe its construction with neat sketch. [8]
6. a) Determine the size of rectangular sedimentation tank having its length as twice of its width to settle the particles with settling velocity of 0.2 mm/sec with a settling period of 3 hours to treat water for population of 20000 with a peak allowance of 112 lpcd. [8]  
b) What do you mean by aeration of water? Why it is required? Describe the various methods of aeration. [8]  
c) Explain break point chlorination. Calculate the required quantity of commercial bleaching powder for the disinfection of water in rural water supply schemes: [8]  
i) Chlorine content in the commercial bleaching powder = 35%  
ii) Dose of chlorine = 2.00 mg/l  
iii) Water demand per day = 500000 liters

04 TRIBHUVAN UNIVERSITY  
INSTITUTE OF ENGINEERING  
Examination Control Division  
2070 Chaitra

Exam.	Old Back (2065 & Earlier Batch)		
Level	BE	Full Marks	80
Programme	BCE	Pass Marks	32
Year / Part	III / I	Time	3 hrs.

*Subject: - Water Supply Engineering (EG628CE)*

- ✓ Candidates are required to give their answers in their own words as far as practicable.
- ✓ Attempt any **Five** questions.
- ✓ **All** questions carry equal marks.
- ✓ Assume suitable data if necessary.

1. a) Discuss briefly about the faecal oral transmission route. Draw the schematic flow diagram of water supply system in rural and urban sectors and briefly describe major function of each component.
- b) A newly established town with a population of 1.3 million is to be supplied with water daily at 110 liters per head. The variation in demand is as follows.

Time	Consumption %
05.00-10.00	55
10.00-14.00	10
14.00-18.00	20
18.00-22.00	10
22.00-05.00	5

Determine analytically the balancing reservoir capacity assuming pumping to be done at a uniform rate and the period of pumping is 5 A.M to 6 P.M. Neglect fire demand.

2. a) What are indicator organisms? Describe in detail about the membrane filter technique for the determination of E-coil in laboratory.
- b) Determine the settling velocity of a discrete particle having the diameter 0.17 mm; specific gravity 2.65 in water. The temperature of fluid is 21°C.
3. a) Explain theory of sedimentation with coagulation in water supply system. What are the factors affecting chlorination?
- b) Determine the population of a rural area for the year 2055AD (any four methods). Compute the expected daily water quantity requirement for one proposed population with justification.

Year	1971	1981	1991	2001	2011
Population	32000	36000	44000	52000	57000

4. a) Describe the various water borne diseases that are transmitted through polluted water and their preventive strategies.
- b) Average water consumption rate is 45 lps in the village. Design a slow sand filtration unit for a community having the population of 3500 at the base year 2048AD. Assume necessary data suitably.

5. a) What is the purpose of aeration? Discuss various aeration methods commonly used in water treatment.
- b) Design suitable diameter of continuous main transmission pipe lines PQ and QR shown below. The average water requirement is 60 lpcd. The storage tank is fixed at point P of R.L. 325.0m. The water is distributed only after the point Q for a population of 2500 and R for a population of 21000. If the minimum pressure head of water is to be 15.0m at Q and R. Assume Hazen Williams' coefficient C as 100 and other necessary requirements if necessary.

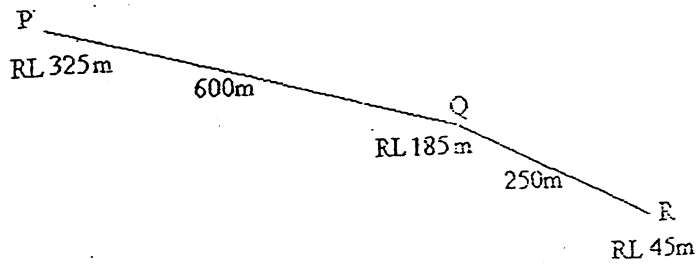

6. Write short notes on: (any four)

- GI and CI pipe
- Jar test
- Public stand post
- Spigot and socket joint
- Globe valve

\*\*\*

Exam.	New 7/2000 & 2000 (2000)		
Level	BE	Full Marks	80
Programme	BCE	Pass Marks	32
Year / Part	III / I	Time	3 hrs.

**Subject: - Water Supply Engineering (CE605)**

- ✓ Candidates are required to give their answers in their own words as far as practicable.
- ✓ Attempt All questions.
- ✓ The figures in the margin indicate Full Marks.
- ✓ Assume suitable data if necessary.

1. Why a systematic water-supply scheme is necessary in the community? Describe the impacts of such water supply schemes. [2+2]
2. Describe the selection criteria of a good source for drinking water supply project. [4]
3. In a rural village, the survey is carried out in the year 2070 BS and the following data is obtained: [8]
 

Population = 5000 nos	No of cows = 50 nos
No of goats = 250 nos	No of chickens = 2000 nos
No of VDC offices = 2 nos	No of tea shops = 3 nos
No of schools = 2 with overall 350 day scholar students.	
Annual population growth rate = 1.5% and	
Annual growth rate for students = 1%	

If the base year is taken as 2073 BS and the design period is of 20 years, calculate the total water demand of the village for the service year?
4. a) What do you understand by water-vector-disease? Describe any two types of water vector diseases. [4]
- b) The total hardness value obtained from the analysis of a water sample is 150 mg/l. If all three (Ca, Mg and Sr) cations concentration causing hardness are numerically same and carbonate hardness is 77 mg/l, calculate the following: [4]
  - i) The value of non carbonate hardness
  - ii) The concentration of principal cations and
  - iii) The value of total alkalinity in mg/l.
5. a) Describe spring intake with a neat sketch showing plan, elevation, section and protection work. [8]
- b) A small village has design year population of 600 with 65 lpcd per capita demand. The demand is to be fulfilled by spring sources with safe yield 0.5 l/s. The consumption pattern in % of a day is as below. [8]
 

Time	05-07	07-12	12-17	17-19	19-05
Water consumption (%)	30	30	15	20	5

Is balancing reservoir necessary? Calculate capacity of balancing reservoir if needed.
- c) Describe briefly the design criteria and design steps involved in rural water supply distribution system. [8]
6. a) With neat sketches, describe the various types of mixing devices used in mixing the coagulant with water. [8]
- b) In a continuous flow settling tank 30 m long and 3 m deep, what detention time would you recommend for effective removal of 0.02 mm particles at 25°C? Assume specific gravity of particles = 2.65. Also determine the percentage of 0.01 mm particles removed in the same tank at 10°C. [8]
- c) Describe in detail the various forms of chlorination. [8]
7. Describe the public stand post with neat sketch and necessary criteria. [8]
8. What are the requirements of a good pipe material? Describe a flanged joint with neat sketch. [4]



Exam.	Regular		
Level	BE	Full Marks	80
Programme	BCE	Pass Marks	32
Year / Part	III / I	Time	3 hrs.

**Subject: - Water Supply Engineering (CE605)**

- ✓ Candidates are required to give their answers in their own words as far as practicable.
- ✓ Attempt All questions.
- ✓ The figures in the margin indicate Full Marks.
- ✓ Assume suitable data if necessary.

1. Enlist objectives of water supply system focusing for rural water supply in Nepal. Draw its schematic diagram mentioning components. [4]
2. The city has an average water demand of 6202 million liters per month. Calculate the capacity of impounded reservoir. The flow in the river is shown below. [4]

Month	Inflow (m <sup>3</sup> /s)
January	2.97
February	1.99
March	1.00
April	0.00

Month	Inflow (m <sup>3</sup> /s)
May	0.51
June	1.00
July	2.00
August	3.00

Month	Inflow (m <sup>3</sup> /s)
September	4.00
October	5.00
November	4.00
December	2.80

3. The survey data collected for a water supply scheme in a village of Nepal is given below: [8]
  - Survey year = 2013
  - Base period = 3 years
  - Design period = 15 years
  - Population = 250
  - No. of cows = 200
  - No. of goats = 500
  - No. of chickens = 5000
  - Annual population growth rate = 1.5%
  - No. of day scholars in school = 100
  - No. of boarders in school = 10
  - No. of health post = 1
  - No. of tea shop = 1
  - VDC office = 1
 Calculate total water demand for design year.
4. a) Describe fecal-oral transmission route of disease with a neat schematic diagram. [4]
  - b) If 400ml of water with a pH of 6 is mixed with 700ml of water with a pH of 8, what will be the resultant pH of the mixture? [4]
5. What are the factors that should be considered during selection of an intake site? With neat sketches, describe the construction of a spring intake. [8]
6. a) Find the settling velocity of silica particle of size 0.02cm with specific gravity 2.65 in water at 20°C? Take kinematic viscosity of water at 20°C as 1.007 centistokes. [8]
  - b) Design rapid sand filter for a population of 60000 nos for a newly growing urban area. [8]
  - c) What is break point chlorination? How can you obtain the break point? Describe. How much quantity of bleaching power is to be added in the treatment plant to disinfect 2 MLD of water, if the dose of chlorine is 0.5 ppm? [8]

7. a) Briefly describe the layout of distribution system with their advantages and disadvantages. How can you improve the traditional layout system for betterment? [6+2]
- b) Design pipes RA and AB for the water distribution network shown below: [8]

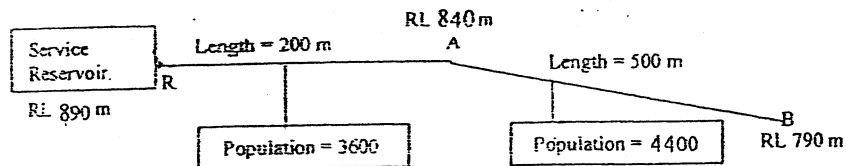

Take per capita demand of water as 200 lpcd. Assume peak factor = 3 and Hazen Williams Constant  $C = 100$ . The residual pressure at any point in the distribution system should not be less than 15m. Check velocity in the pipes also.

8. Describe briefly the process of pipe laying and jointing. [4]
9. Why pressure relief valves are necessary? Describe with a neat sketch. [1+3]

\*\*\*



02A TRIBHUVAN UNIVERSITY  
INSTITUTE OF ENGINEERING

Examination Control Division  
2069 Ashad

Exam.	New Back (2066 & Later Batch)		
Level	BE	Full Marks	80
Programme	BCE	Pass Marks	32
Year / Part	III / I	Time	3 hrs.

**Subject: - Water Supply Engineering (CE 605)**

- ✓ Candidates are required to give their answers in their own words as far as practicable.
- ✓ Attempt All questions.
- ✓ The figures in the margin indicate Full Marks.
- ✓ Assume suitable data if necessary.

1. Describe briefly about objectives of water supply and its necessary components for water supply system. [4]
2. Describe various sources of surface water with respect to their quantity and quality. [4]
3. Draw a schematic diagram of a typical water supply system and list its components. Determine the population of the town in year 2021 and 2026 by (i) Arithmetical increase method and (ii) Decreased rate of growth method from the following details: [8]

Year A.D.	1961	1971	1981	1991	2001	2011
Population	18000	27000	38000	51000	66000	83000

4. What are indicator organism? Describe in detail about the membrane tube fermentation technique for the determination of E-coil in laboratory. [8]
5. What is an intake? Describe spring intake with neat sketches. [8]
6. a) Find the quantity of alum and chlorine required in a treatment plant of capacity 12 million lit/day. If optimum dose of alum is 3 mg/l and residual chlorine is expected in the distribution pipe is at the concentration of 0.2mg/l. [8]
- b) Find the settling velocity of silica particle of specific gravity 2.65 at 10°C if the diameter of the particle is 0.05cm. Assume kinematic viscosity at 10°C is 0.91 centistokes. [8]
- c) Design a rectangular shape plane sedimentation tank to treat 3.75 l/s of water. Assume effective depth as 2.1m and detention time as 4 hours. [8]
7. a) Compare the continuous and intermittent system of water supply. [6]
- b) Calculate the discharge in pipes AB, BC, AD and CD for the water distribution network giving below by using Hardy-cross method. The available data of network are as follows: [10]

Pipe	Length (in meter)	Diameter (in mm)
AB	400	300
BC	300	200
AD	500	400
CD	500	300

Hazen Williams coefficient as 100 for all pipes. Assume other necessary data suitably.

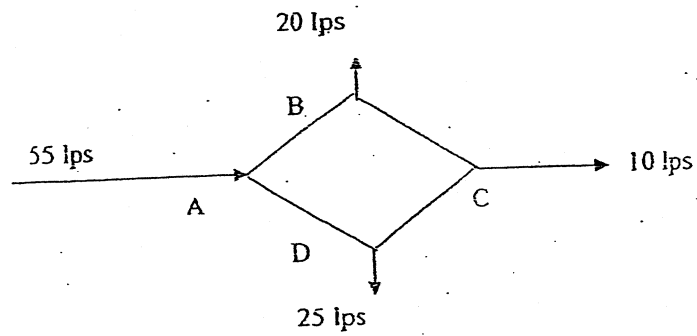

8. Describe briefly the flanged joint and reflux valve with neat sketches. [4]
9. Describe the construction of break pressure tank with neat sketches. [4]

\*\*\*

Exam.	Regular		
Level	BE	Full Marks	80
Programme	BCE	Pass Marks	32
Year / Part	III / I	Time	3 hrs.

**Subject: - Water Supply Engineering (CE 605)**

- ✓ Candidates are required to give their answers in their own words as far as practicable.
- ✓ Attempt All questions.
- ✓ The figures in the margin indicate Full Marks.
- ✓ Assume suitable data if necessary.

- ① 1. Draw a schematic diagram of a typical water supply system and list its components. [4]
2. What are indicator organism? Describe in detail about the membrane tube fermentation technique for the determination of E-coli in laboratory. [8]
- ③ 3. a) An old tank having dimension of 12m × 5m × 3m is available in a village. It is proposed to use as a settling tank. At least 95 percentage of particles having diameter of 0.025mm, specific gravity 2.65 is expected to remove on that tank at 20°C. What will be an overflow rate on using that tank? Does tank dimension is enough to remove 99 percentage of particles having diameter 0.04mm at same conditions? [10]
- b) Suppose you are a team member of a pre-feasibility study for a rural water supply project. How do you convince the community during disputes regarding the ownership of water sources and priorities of using water sources? [4]
4. a) Enlist the requirements of the public stand post along with its importance in rural areas. [4]
- ⑥ b) Explain break point chlorination in relation to water supply system. Explain significance of residual disinfectant. [6]
- ⑦ 5. a) Design pipelines AB, BC and AD for the following pipe network. A minimum pressure of 1 kg/cm<sup>2</sup> is required at the tap. Take Hazen william constant C = 100. [8]

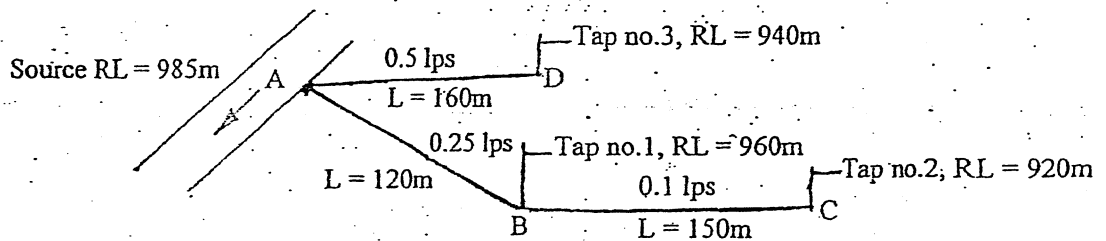

- b) Describe, with their respective merit and demerit, of various methods of distribution of water. [8]
- ③ 6. When reservoir intake is constructed? Describe a typical reservoir intake. [8]
- OR
- Describe a dry type river intake with a neat sketch.
- ⑥ 7. With neat sketches describe the construction of rapid sand filter. [8]

*Handwritten notes and signatures at the bottom of the page.*

OR

What are the purpose of aeration? Describe the various methods of aeration.

8. Why pipe joints are required? Describe socket and spigot joint with a neat sketch. [4]
9. Determine the population of the town in the year 2021 and 2026 by (i) Arithmetical increase method (ii) Geometrical increase method and (iii) Decreased rate of growth method. [8]

Year A.D	1961	1971	1981	1991	2001	2011
Population	18000	27000	38000	51000	66000	83000

\*\*\*

05 TRIBHUVAN UNIVERSITY  
 INSTITUTE OF ENGINEERING  
 Examination Control Division  
 2068 Baishakh

Exam.	Regular / Back		
	Level	BE	Full Marks
Programme	BCE	Pass Marks	32
Year / Part	III / I	Time	3 hrs.

**Subject: - Water Supply Engineering**

- ✓ Candidates are required to give their answers in their own words as far as practicable.
- ✓ Attempt any Five questions.
- ✓ The figures in the margin indicate Full Marks.
- ✓ Assume suitable data if necessary.

1 a) Draw typical flow diagrams of rural and urban water supply schemes showing the essential components. Describe the function of each component. [4+4]

b) The yield of water from a catchment area is given below. Determine analytically the minimum storage capacity of impounded reservoir to maintain a constant draft of 4.4 million m<sup>3</sup> of water per month. Neglect all losses and wastage. [8]

Month	Jan	Feb	Mar	Apr	May	Jun	Jul	Aug	Sep	Oct	Nov	Dec
Inflow million m <sup>3</sup>	1.5	2.0	2.5	5.0	6.0	8.2	9	7.5	5.0	3.5	3.1	2.0

2.3 a) Briefly describe about variation of demand and factors affecting the water demand. [8]

b) Estimate the total water requirement for a rural area for the year 2025 AD by forecasting the population by incremental increase method with the following data. [8]

Year	1950	1960	1970	1980	1990	2000
Population	7150	7680	8425	9265	11780	14339

There are 4 schools with 125 day scholar students and staffs in each school, livestock (3520 chicken/ducks and 170 big animals), 2 health posts with 5 beds capacity and other offices with 345 staffs altogether.

3. a) Describe different types of water borne diseases, their transmission mechanism and preventive measures in brief. [8]

b) In a continuous flow settling tank 30m long and 3m deep, what velocity of water would you recommend for effective removal of 0.02mm particles. Express the velocity in mm/min. Assume specific gravity of particles = 2.65 and kinematic viscosity of water = 0.01 cm<sup>2</sup>/sec. [8]

4. a) With neat sketches describe a spring intake. [8]

b) Average water consumption rate is 150 lpcd in an urban area. Design a slow sand filtration unit for a community having the population of 10000 at the base year 2068. [8]

5. a) Describe the factors that should be considered while selecting pipe materials for water supply schemes. Give comparative merits and demerits of cast iron and steel pipes. [4+4]

- b) A newly established town with a population of 1.2 million is to be supplied with water daily at 45 liters per capita. Water have to be stored also for fire demand keeping at least 1% of total demand. The variation in demand is as follows:

[8]

Time	Consumption %
05.00 – 07.00	25
07.00 – 12.00	35
12.00 – 17.00	20
17.00 – 19.00	20
19.00 – 05.00	0

Determine analytically the balancing reservoir capacity assuming pumping to be done at on uniform rate and the period of pumping is 5.00 A.M. to 10.00 A.M. and 5.00 P.M. to 8.00 P.M. in two shifts.

[4×4]

6. Write short notes on: (any four)
- a) Public Standpost
  - b) Systems of Water Supply
  - c) Socket and Spigot Joint
  - d) Maintenance of Water Supply Scheme
  - e) Laying of Pipeline
  - f) Infiltration Gallery

\*\*\*